

# ASTRO® XTS™ 5000

VHF

UHF Range 1

UHF Range 2

700 — 800 MHz

Digital Portable Radios

Detailed Service Manual



**MOTOROLA**

*intelligence everywhere™*







**MOTOROLA**  
*intelligence everywhere™*

**ASTRO® XTS™ 5000**  
**VHF/UHF Range 1/Range 2/700–800 MHz**  
**Digital Portable Radios**  
**Detailed Service Manual**

# Foreword

The information contained in this manual relates to all ASTRO® XTS™ 5000 digital portable radios, unless otherwise specified. This manual provides sufficient information to enable qualified service shop technicians to troubleshoot and repair an ASTRO XTS 5000 digital portable radio to the component level.

For details on the operation of the radio or level 1 or 2 maintenance procedures, refer to the applicable manuals, which are available separately. A list of related publications is provided in the section, "Related Publications," on page xii.

## Product Safety and RF Exposure Compliance

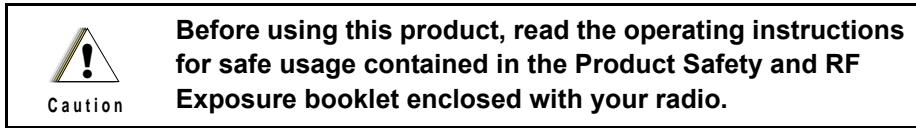

### ATTENTION!

**This radio is restricted to occupational use only to satisfy FCC RF energy exposure requirements. Before using this product, read the RF energy awareness information and operating instructions in the Product Safety and RF Exposure booklet enclosed with your radio (Motorola Publication part number 6881095C98) to ensure compliance with RF energy exposure limits.**

**For a list of Motorola-approved antennas, batteries, and other accessories, visit the following web site which lists approved accessories: <http://www.motorola.com/cgiss/index.shtml>**

## Manual Revisions

Changes which occur after this manual is printed are described in FMRs (Florida Manual Revisions). These FMRs provide complete replacement pages for all added, changed, and deleted items, including pertinent parts list data, schematics, and component layout diagrams. To obtain FMRs, contact the Customer Care and Services Division (refer to "Appendix A Replacement Parts Ordering").

## Computer Software Copyrights

The Motorola products described in this manual may include copyrighted Motorola computer programs stored in semiconductor memories or other media. Laws in the United States and other countries preserve for Motorola certain exclusive rights for copyrighted computer programs, including, but not limited to, the exclusive right to copy or reproduce in any form the copyrighted computer program. Accordingly, any copyrighted Motorola computer programs contained in the Motorola products described in this manual may not be copied, reproduced, modified, reverse-engineered, or distributed in any manner without the express written permission of Motorola. Furthermore, the purchase of Motorola products shall not be deemed to grant either directly or by implication, estoppel, or otherwise, any license under the copyrights, patents or patent applications of Motorola, except for the normal non-exclusive license to use that arises by operation of law in the sale of a product.

## Document Copyrights

No duplication or distribution of this document or any portion thereof shall take place without the express written permission of Motorola. No part of this manual may be reproduced, distributed, or transmitted in any form or by any means, electronic or mechanical, for any purpose without the express written permission of Motorola.

## Disclaimer

The information in this document is carefully examined, and is believed to be entirely reliable. However, no responsibility is assumed for inaccuracies. Furthermore, Motorola reserves the right to make changes to any products herein to improve readability, function, or design. Motorola does not assume any liability arising out of the applications or use of any product or circuit described herein; nor does it cover any license under its patent rights nor the rights of others.

## Trademarks

MOTOROLA, the Stylized M logo, and ASTRO are registered in the US Patent & Trademark Office. All other product or service names are the property of their respective owners.



---

# Table of Contents

<b>Foreword</b> .....	<b>ii</b>
Product Safety and RF Exposure Compliance .....	ii
Manual Revisions .....	ii
Computer Software Copyrights .....	ii
Document Copyrights .....	ii
Disclaimer .....	ii
Trademarks .....	ii
<b>List of Figures</b> .....	<b>vii</b>
<b>List of Tables</b> .....	<b>xi</b>
<b>Commercial Warranty</b> .....	<b>xiii</b>
Limited Warranty .....	xiii
<b>Model Numbering, Charts, and Specifications</b> .....	<b>xvii</b>
Portable Radio Model Numbering System .....	xvii
ASTRO XTS 5000 VHF Model Chart .....	xviii
ASTRO XTS 5000 R (Ruggedized) VHF Model Chart .....	xix
ASTRO XTS 5000 UHF Range 1 Model Chart .....	xx
ASTRO XTS 5000 R (Ruggedized) UHF Range 1 Model Chart .....	xxi
ASTRO XTS 5000 UHF Range 2 Model Chart .....	xxii
ASTRO XTS 5000 R (Ruggedized) UHF Range 2 Model Chart .....	xxiii
ASTRO XTS 5000 700–800 MHz Model Chart .....	xxiv
ASTRO XTS 5000 R (Ruggedized) 700–800 MHz Model Chart .....	xxv
Specifications for VHF Radios .....	xxvi
Specifications for UHF Range 1 Radios .....	xxvii
Specifications for UHF Range 2 Radios .....	xxviii
Specifications for 700–800 MHz Radios .....	xxix
<b>Chapter 1 Introduction</b> .....	<b>1-1</b>
1.1 General .....	1-1
1.2 Notations Used in This Manual .....	1-2
<b>Chapter 2 Radio Power</b> .....	<b>2-1</b>
2.1 General .....	2-1
2.2 DC Power Routing—Transceiver Board .....	2-3
2.3 DC Power Routing—VOCON Board .....	2-3

---

<b>Chapter 3</b>	<b>Theory of Operation.....</b>	<b>3-1</b>
3.1	Transceiver Board.....	3-2
3.2	VOCON Board.....	3-16
3.3	Encryption Module.....	3-34
<b>Chapter 4</b>	<b>Troubleshooting Procedures.....</b>	<b>4-1</b>
4.1	Handling Precautions.....	4-1
4.2	Recommended Service Tools.....	4-2
4.3	Voltage Measurement and Signal Tracing.....	4-3
4.4	Standard Bias Table.....	4-4
4.5	Power-Up Self-Check Errors.....	4-5
4.6	Power-Up Self-Check Diagnostics and Repair (Not for Field Use).....	4-6
<b>Chapter 5</b>	<b>Troubleshooting Charts.....</b>	<b>5-1</b>
5.1	List of Troubleshooting Charts.....	5-1
5.2	Main Troubleshooting Flowchart.....	5-2
5.3	Power-Up Failure.....	5-3
5.4	DC Supply Failure.....	5-5
5.5	Display Failure (NNTN4563, NNTN4819, & NNTN4717 VOCON Kits).....	5-8
5.6	Display Failure (NTN9564).....	5-11
5.7	Volume Set Error.....	5-14
5.8	Channel/Zone Select Error.....	5-15
5.9	Button Test.....	5-16
5.10	Top/Side Button Test.....	5-17
5.11	VCO TX/RX Unlock.....	5-18
5.12	VOCON TX Audio—Page 1.....	5-19
5.13	VOCON RX Audio.....	5-21
5.14	RX RF.....	5-23
5.15	TX RF (VHF and UHF Range 2).....	5-28
5.16	TX RF (UHF R1/700-800 MHz).....	5-31
5.17	Keyload Failure.....	5-34
5.18	Secure Hardware Failure.....	5-35
<b>Chapter 6</b>	<b>Troubleshooting Waveforms.....</b>	<b>6-1</b>
6.1	List of Waveforms.....	6-1
6.2	13 MHz Clock.....	6-2
6.3	16.8 MHz Buffer Input and Output.....	6-3
6.4	32.768 kHz Clock Outputs.....	6-4
6.5	SPI B Data.....	6-5
6.6	Receive Serial Audio Port (SAP).....	6-6
6.7	Receive Baseband Interface Port (RX BBP).....	6-7
6.8	Transmit Baseband Interface Port (TX BBP).....	6-8
<b>Chapter 7</b>	<b>Troubleshooting Tables.....</b>	<b>7-1</b>
7.1	List of Board and IC Signals.....	7-1

---

---

**Chapter 8 Schematics, Board Overlays, and Parts Lists ..... 8-1**

8.1	List of Transceiver Schematics and Board Overlays .....	8-1
8.2	List of VOCON Schematics and Board Overlays.....	8-1
8.3	Transceiver (RF) Boards .....	8-3
8.4	VOCON Boards .....	8-96

## Notes

---

## List of Figures

Figure 2-1. DC Power Distribution—UHF Range 1 and 700–800 MHz Radios .....	2-2
Figure 2-2. DC Power Distribution—VHF and Range 2 Radios .....	2-2
Figure 3-1. XTS 5000 Overall Block Diagram .....	3-2
Figure 3-2. Transceiver (VHF) Block Diagram (Power and Control Omitted) .....	3-2
Figure 3-3. Transceiver (UHF Range 1, UHF Range 2 and 700–800 MHz) Block Diagram (Power and Control Omitted)3-3	
Figure 3-4. Receiver Block Diagram .....	3-5
Figure 3-5. Abacus III (AD9874) Functional Block Diagram (from data sheet) .....	3-7
Figure 3-6. Transmitter Block Diagram .....	3-9
Figure 3-7. VOCON Board Interconnections.....	3-16
Figure 3-8. Patriot EIM and Memory Block Diagram.....	3-21
Figure 3-9. Universal (Side) Connector.....	3-28
Figure 3-10. VOCON Board Connector—J101 .....	3-28
Figure 3-11. Control Top Flex.....	3-31
Figure 3-12. VOCON Transmit Audio Path .....	3-32
Figure 3-13. VOCON Receive Audio Path .....	3-33
Figure 6-1. 13 MHz Clock Waveform .....	6-2
Figure 6-2. 16.8 MHz Buffer Input and Output Waveforms .....	6-3
Figure 6-3. 32.768 kHz Clock Outputs Waveforms .....	6-4
Figure 6-4. SPI B Data Waveforms .....	6-5
Figure 6-5. Receive Serial Audio Port (SAP) Waveforms .....	6-6
Figure 6-6. Receive Baseband Interface Port (RX BBP) Waveforms .....	6-7
Figure 6-7. Transmit Baseband Interface Port (TX BBP) Waveforms .....	6-8
Figure 8-1. NUF3577 700–800 MHz Transceiver (RF) Board Overall Circuit Schematic .....	8-3
Figure 8-2. NUF3577 700–800 MHz Antenna Switch and Harmonic Filter Circuits .....	8-4
Figure 8-3. NUF3577 700–800 MHz Receiver Front End Circuit.....	8-5
Figure 8-4. NUF3577 700–800 MHz Receiver Back End Circuit .....	8-6
Figure 8-5. NUF3577 700–800 MHz Transmitter and Automatic Level Control Circuits.....	8-7
Figure 8-6. NUF3577 700–800 MHz Frequency Generation Unit (Synthesizer) Circuit—1 of 2 .....	8-8
Figure 8-7. NUF3577 700–800 MHz Frequency Generation Unit (VCO) Circuit—2 of 2 .....	8-9
Figure 8-8. NUF3577 700–800 MHz Transceiver (RF) Board Layout—Side 1 .....	8-10
Figure 8-9. NUF3577 700–800 MHz Transceiver (RF) Board Layout—Side 2 .....	8-11
Figure 8-10. NUF3577C 700–800 MHz Transceiver (RF) Board Overall Circuit Schematic.....	8-17
Figure 8-11. NUF3577C 700–800 MHz Antenna Switch and Harmonic Filter Circuits .....	8-18
Figure 8-12. NUF3577C 700–800 MHz Receiver Front End Circuit .....	8-19
Figure 8-13. NUF3577C 700–800 MHz Receiver Back End Circuit.....	8-20
Figure 8-14. NUF3577C 700–800 MHz Transmitter and Automatic Level Control Circuits .....	8-21
Figure 8-15. NUF3577C 700–800 MHz Frequency Generation Unit (Synthesizer) Circuit.....	8-22
Figure 8-16. NUF3577C 700–800 MHz Frequency Generation Unit (VCO) Circuit.....	8-23
Figure 8-17. NUF3577C 700–800 MHz Transceiver (RF) Board Layout—Side 1 .....	8-24
Figure 8-18. NUF3577C 700–800 MHz Transceiver (RF) Board Layout—Side 2 .....	8-25
Figure 8-19. NLD8910B VHF Transceiver (RF) Board Overall Circuit Schematic .....	8-31
Figure 8-20. NLD8910B VHF DC Power Circuits.....	8-32
Figure 8-21. NLD8910B VHF Antenna Switch and Harmonic Filter Circuits.....	8-33
Figure 8-22. NLD8910B VHF Receiver Front End Circuit.....	8-34
Figure 8-23. NLD8910B VHF Receiver Amplifier and Filter Circuit.....	8-35
Figure 8-24. NLD8910B VHF Mixer and IF Filter Circuits .....	8-36
Figure 8-25. NLD8910B VHF Receiver Back End Circuit .....	8-37

Figure 8-26. NLD8910B VHF Transmitter and Automatic Level Control Circuits .....	8-38
Figure 8-27. NLD8910B VHF Frequency Generation Unit (Synthesizer) Circuit.....	8-39
Figure 8-28. NLD8910B VHF Frequency Generation Unit (VCO) Circuit.....	8-40
Figure 8-29. NLD8910B VHF Transceiver (RF) Board Layout—Side 1 .....	8-41
Figure 8-30. NLD8910B VHF Transceiver (RF) Board Layout—Side 2 .....	8-42
Figure 8-31. NLE4272A UHF Range 1 Transceiver (RF) Board Overall Circuit Schematic.....	8-48
Figure 8-32. NLE4272A UHF Range 1 Antenna Switch and Harmonic Filter Circuits .....	8-49
Figure 8-33. NLE4272A UHF Range 1 Receiver Front End (RX_FE) Circuit.....	8-50
Figure 8-34. NLE4272A UHF Range 1 Receiver Back End (RX_BE) Circuit.....	8-51
Figure 8-35. NLE4272A UHF Range 1 Transmitter Power Amplifier and Automatic Level Control (TX_ALC) Circuit.....	8-52
Figure 8-36. NLE4272A UHF Range 1 Frequency Generation Unit (Synthesizer) Circuit .....	8-53
Figure 8-37. NLE4272A UHF Range 1 Frequency Generation Unit (VCO) Circuit .....	8-54
Figure 8-38. NLE4272A UHF Range 1 Transceiver (RF) Board Layout—Side 1.....	8-55
Figure 8-39. NLE4272A UHF Range 1 Transceiver (RF) Board Layout—Side 2.....	8-56
Figure 8-40. NLE4278A UHF Range 1 Transceiver (RF) Board Overall Circuit Schematic.....	8-64
Figure 8-41. NLE4278A UHF Range 1 Antenna Switch and Harmonic Filter Circuits .....	8-65
Figure 8-42. NLE4278A UHF Range 1 Receiver Front End Circuit.....	8-66
Figure 8-43. NLE4278A UHF Range 1 Receiver Back End Circuit.....	8-67
Figure 8-44. NLE4278A UHF Range 1 Transmitter Power Amplifier and Automatic Level Control Circuit .....	8-68
Figure 8-45. NLE4278A UHF Range 1 Frequency Unit (Synthesizer) Circuit.....	8-69
Figure 8-46. NLE4278A UHF Range 1 Frequency Generation Unit (VCO) Circuit .....	8-70
Figure 8-47. NLE4278A UHF Range 1 Transceiver (RF) Board Layout—Side 1.....	8-71
Figure 8-48. NLE4278A UHF Range 1 Transceiver (RF) Board Layout—Side 2.....	8-72
Figure 8-49. NLE 4273A UHF Range 2 Transceiver (RF) Board Overall Circuit Schematic.....	8-79
Figure 8-50. NLE 4273A UHF Range 2 D/C Power Circuit Schematic .....	8-80
Figure 8-51. NLE 4273A UHF Range 2 Antenna Switch and Harmonic Filter Circuit Schematic .....	8-81
Figure 8-52. NLE 4273A UHF Range 2 Receiver Front End Circuit Schematic.....	8-82
Figure 8-53. NLE 4273A UHF Range 2 Receiver Back End Circuit Schematic .....	8-83
Figure 8-54. NLE 4273A UHF Range 2 Receiver Amplifier and Filter Circuit Schematic.....	8-84
Figure 8-55. NLE 4273A UHF Range 2 Mixer and IF Filter Circuit Schematic.....	8-85
Figure 8-56. NLE 4273A UHF Range 2 Transmitter and Automatic Level Control Circuit Schematic .....	8-86
Figure 8-57. NLE 4273A UHF Range 2 Frequency Generation Unit (Synthesizer) Circuit Schematic .....	8-87
Figure 8-58. NLE 4273A UHF Range 2 Frequency Generation Unit (VCO) Circuit Schematic .....	8-88
Figure 8-59. NLE 4273A UHF Range 2 Transceiver Board Layout (Side 1) Schematic .....	8-89
Figure 8-60. NLE 4273A UHF Range 2 Transceiver (RF) Board Layout (Side 2) Schematic.....	8-90
Figure 8-61. NTN9564B VOCON Board Overall Schematic—1 of 2.....	8-96
Figure 8-62. NTN9564B VOCON Board Overall Schematic—2 of 2.....	8-97
Figure 8-63. NTN9564B VOCON Universal Connector Circuit .....	8-98
Figure 8-64. NTN9564B VOCON Flipper Circuit.....	8-99
Figure 8-65. NTN9564B VOCON Controller and Memory Circuits—1 of 2.....	8-100
Figure 8-66. NTN9564B VOCON Controller and Memory Circuits—2 of 2.....	8-101
Figure 8-67. NTN9564B VOCON Audio and DC Circuits.....	8-102
Figure 8-68. NTN9564B VOCON Board Layout—Side 1 .....	8-103
Figure 8-69. NTN9564B VOCON Board Layout—Side 2 .....	8-104
Figure 8-70. NTN9564C VOCON Board Overall Schematic—1 of 2.....	8-110
Figure 8-71. NTN9564C VOCON Board Overall Schematic—2 of 2.....	8-111
Figure 8-72. NTN9564C VOCON Universal Connector Circuit .....	8-112
Figure 8-73. NTN9564C VOCON Flipper Circuit.....	8-113
Figure 8-74. NTN9564C VOCON Controller and Memory Circuits—1 of 2.....	8-114
Figure 8-75. NTN9564C VOCON Controller and Memory Circuits—2 of 2.....	8-115
Figure 8-76. NTN9564C VOCON Audio and DC Circuits.....	8-116
Figure 8-77. NTN9564C VOCON Board Layout—Side 1.....	8-117

---

Figure 8-78. NTN9564C VOCON Board Layout—Side 2.....	8-118
Figure 8-79. NNTN4563A/B VOCON Board Overall Schematic—1 of 2.....	8-124
Figure 8-80. NNTN4563A/B VOCON Board Overall Schematic—2 of 2.....	8-125
Figure 8-81. NNTN4563A/B VOCON Universal Connector Circuit.....	8-126
Figure 8-82. NNTN4563A/B VOCON Flipper Circuit.....	8-127
Figure 8-83. NNTN4563A/B VOCON Controller and Memory Circuits—1 of 2.....	8-128
Figure 8-84. NNTN4563A/B VOCON Controller and Memory Circuits—2 of 2.....	8-129
Figure 8-85. NNTN4563A/B VOCON Audio and DC Circuits.....	8-130
Figure 8-86. NNTN4563A/B VOCON Board Layout—Side 1.....	8-131
Figure 8-87. NNTN4563A/B VOCON Board Layout—Side 2.....	8-132
Figure 8-88. NNTN4819A VOCON Board Overall Schematic—Sheet 1 of 2.....	8-139
Figure 8-89. NNTN4819A VOCON Board Overall Schematic—Sheet 2 of 2.....	8-140
Figure 8-90. NNTN4819A VOCON Universal Connector and ESD Circuits.....	8-141
Figure 8-91. NNTN4819A VOCON Flipper Circuit.....	8-142
Figure 8-92. NNTN4819A VOCON Controller and Memory Circuits—Sheet 1 of 2.....	8-143
Figure 8-93. NNTN4819A VOCON Controller and Memory Circuits—Sheet 2 of 2.....	8-144
Figure 8-94. NNTN4819A VOCON Audio/DC Circuits.....	8-145
Figure 8-95. NNTN4819A VOCON Board Layout—Side 1.....	8-146
Figure 8-96. NNTN4819A VOCON Board Layout—Side 2.....	8-147
Figure 8-97. NNTN4717D VOCON Board Overall Schematic—Sheet 1 of 2.....	8-153
Figure 8-98. NNTN4717D VOCON Board Overall Schematic—Sheet 2 of 2.....	8-154
Figure 8-99. NNTN4717D VOCON Board Universal Connector Circuit Schematic.....	8-155
Figure 8-100. NNTN4717D VOCON Board Flipper Circuit.....	8-156
Figure 8-101. NNTN4717D VOCON Board Controller and Memory Circuits—Sheet 1 of 2.....	8-157
Figure 8-102. NNTN4717D VOCON Board Controller and Memory Circuits—Sheet 2 of 2.....	8-158
Figure 8-103. NNTN4717D VOCON Board Audio/DC Circuits.....	8-159
Figure 8-104. NNTN4717D VOCON Board Layout—Side 1.....	8-160
Figure 8-105. NNTN4717D VOCON Board Layout—Side 2.....	8-161

## Notes



---

## List of Tables

Table 2-1.	Conventional Batteries.....	2-1
Table 2-2.	Smart Batteries.....	2-1
Table 2-3.	Transceiver Voltage Regulators.....	2-3
Table 2-4.	VOCON Board DC Power Distribution.....	2-4
Table 3-1.	Battery Connector J3.....	3-3
Table 3-2.	VOCON Connector P1.....	3-4
Table 3-3.	Power Control IC (U104) Pin Descriptions.....	3-11
Table 3-4.	Audio PA Status.....	3-24
Table 3-5.	Option-Select Functions.....	3-29
Table 3-6.	Encryption Module Software Kits and Algorithms.....	3-34
Table 4-1.	Recommended Service Tools.....	4-2
Table 4-2.	Standard Operating Bias.....	4-4
Table 4-3.	Power-Up Self-Check Error Codes.....	4-5
Table 4-4.	Power-Up Self-Check Diagnostic Actions.....	4-6
Table 5-1.	Troubleshooting Charts List.....	5-1
Table 6-1.	List of Waveforms.....	6-1
Table 7-1.	List of Tables of Board and IC Signals.....	7-1
Table 7-2.	J101 VOCON Board to Controls Flex Assembly.....	7-1
Table 7-3.	J107 VOCON Board to Keypad Module.....	7-3
Table 7-4.	J701 VOCON Board to Encryption Module.....	7-3
Table 7-5.	U402 FLASH Pinouts.....	7-5
Table 7-6.	U403 SRAM Pinouts.....	7-7
Table 7-7.	U401 Patriot MCU/DSP IC Pinouts.....	7-9
Table 7-8.	U301 Flipper IC Pinouts.....	7-18
Table 7-9.	U501 GCAP II IC Pinouts.....	7-20
Table 8-1.	List of Transceiver Schematics and Board Overlays.....	8-1
Table 8-2.	List of VOCON Schematics and Board Overlays.....	8-1

---

## Notes

---

# Commercial Warranty

## Limited Warranty

### MOTOROLA COMMUNICATION PRODUCTS

#### I. What This Warranty Covers And For How Long

MOTOROLA INC. ("MOTOROLA") warrants the MOTOROLA manufactured Communication Products listed below ("Product") against defects in material and workmanship under normal use and service for a period of time from the date of purchase as scheduled below:

ASTRO XTS 5000 Digital Portable Units	One (1) Year
Product Accessories	One (1) Year

Motorola, at its option, will at no charge either repair the Product (with new or reconditioned parts), replace it (with a new or reconditioned Product), or refund the purchase price of the Product during the warranty period provided it is returned in accordance with the terms of this warranty. Replaced parts or boards are warranted for the balance of the original applicable warranty period. All replaced parts of Product shall become the property of MOTOROLA.

This express limited warranty is extended by MOTOROLA to the original end user purchaser only and is not assignable or transferable to any other party. This is the complete warranty for the Product manufactured by MOTOROLA. MOTOROLA assumes no obligations or liability for additions or modifications to this warranty unless made in writing and signed by an officer of MOTOROLA. Unless made in a separate agreement between MOTOROLA and the original end user purchaser, MOTOROLA does not warrant the installation, maintenance or service of the Product.

MOTOROLA cannot be responsible in any way for any ancillary equipment not furnished by MOTOROLA which is attached to or used in connection with the Product, or for operation of the Product with any ancillary equipment, and all such equipment is expressly excluded from this warranty. Because each system which may use the Product is unique, MOTOROLA disclaims liability for range, coverage, or operation of the system as a whole under this warranty.

#### II. General Provisions

This warranty sets forth the full extent of MOTOROLA's responsibilities regarding the Product. Repair, replacement or refund of the purchase price, at MOTOROLA's option, is the exclusive remedy. THIS WARRANTY IS GIVEN IN LIEU OF ALL OTHER EXPRESS WARRANTIES. IMPLIED WARRANTIES, INCLUDING WITHOUT LIMITATION, IMPLIED WARRANTIES OF MERCHANTABILITY AND FITNESS FOR A PARTICULAR PURPOSE, ARE LIMITED TO THE DURATION OF THIS LIMITED WARRANTY. IN NO EVENT SHALL MOTOROLA BE LIABLE FOR DAMAGES IN EXCESS OF THE PURCHASE PRICE OF THE PRODUCT, FOR ANY LOSS OF USE, LOSS OF TIME, INCONVENIENCE, COMMERCIAL LOSS, LOST PROFITS OR SAVINGS OR OTHER INCIDENTAL, SPECIAL OR CONSEQUENTIAL DAMAGES ARISING OUT OF THE USE OR INABILITY TO USE SUCH PRODUCT, TO THE FULL EXTENT SUCH MAY BE DISCLAIMED BY LAW.

---

### III. State Law Rights

SOME STATES DO NOT ALLOW THE EXCLUSION OR LIMITATION OF INCIDENTAL OR CONSEQUENTIAL DAMAGES OR LIMITATION ON HOW LONG AN IMPLIED WARRANTY LASTS, SO THE ABOVE LIMITATION OR EXCLUSIONS MAY NOT APPLY.

This warranty gives specific legal rights, and there may be other rights which may vary from state to state.

### IV. How To Get Warranty Service

You must provide proof of purchase (bearing the date of purchase and Product item serial number) in order to receive warranty service and, also, deliver or send the Product item, transportation and insurance prepaid, to an authorized warranty service location. Warranty service will be provided by Motorola through one of its authorized warranty service locations. If you first contact the company which sold you the Product, it can facilitate your obtaining warranty service. You can also call Motorola at 1-888-567-7347 US/Canada.

### V. What This Warranty Does Not Cover

- A. Defects or damage resulting from use of the Product in other than its normal and customary manner.
- B. Defects or damage from misuse, accident, water, or neglect.
- C. Defects or damage from improper testing, operation, maintenance, installation, alteration, modification, or adjustment.
- D. Breakage or damage to antennas unless caused directly by defects in material workmanship.
- E. A Product subjected to unauthorized Product modifications, disassemblies or repairs (including, without limitation, the addition to the Product of non-Motorola supplied equipment) which adversely affect performance of the Product or interfere with Motorola's normal warranty inspection and testing of the Product to verify any warranty claim.
- F. Product which has had the serial number removed or made illegible.
- G. Rechargeable batteries if:
  - any of the seals on the battery enclosure of cells are broken or show evidence of tampering.
  - the damage or defect is caused by charging or using the battery in equipment or service other than the Product for which it is specified.
- H. Freight costs to the repair depot.
- I. A Product which, due to illegal or unauthorized alteration of the software/firmware in the Product, does not function in accordance with MOTOROLA's published specifications or the FCC type acceptance labeling in effect for the Product at the time the Product was initially distributed from MOTOROLA.
- J. Scratches or other cosmetic damage to Product surfaces that does not affect the operation of the Product.
- K. Normal and customary wear and tear.

## VI. Patent And Software Provisions

MOTOROLA will defend, at its own expense, any suit brought against the end user purchaser to the extent that it is based on a claim that the Product or parts infringe a United States patent, and MOTOROLA will pay those costs and damages finally awarded against the end user purchaser in any such suit which are attributable to any such claim, but such defense and payments are conditioned on the following:

- A. that MOTOROLA will be notified promptly in writing by such purchaser of any notice of such claim;
- B. that MOTOROLA will have sole control of the defense of such suit and all negotiations for its settlement or compromise; and
- C. should the Product or parts become, or in MOTOROLA's opinion be likely to become, the subject of a claim of infringement of a United States patent, that such purchaser will permit MOTOROLA, at its option and expense, either to procure for such purchaser the right to continue using the Product or parts or to replace or modify the same so that it becomes noninfringing or to grant such purchaser a credit for the Product or parts as depreciated and accept its return. The depreciation will be an equal amount per year over the lifetime of the Product or parts as established by MOTOROLA.

MOTOROLA will have no liability with respect to any claim of patent infringement which is based upon the combination of the Product or parts furnished hereunder with software, apparatus or devices not furnished by MOTOROLA, nor will MOTOROLA have any liability for the use of ancillary equipment or software not furnished by MOTOROLA which is attached to or used in connection with the Product. The foregoing states the entire liability of MOTOROLA with respect to infringement of patents by the Product or any parts thereof.

Laws in the United States and other countries preserve for MOTOROLA certain exclusive rights for copyrighted MOTOROLA software such as the exclusive rights to reproduce in copies and distribute copies of such Motorola software. MOTOROLA software may be used in only the Product in which the software was originally embodied and such software in such Product may not be replaced, copied, distributed, modified in any way, or used to produce any derivative thereof. No other use including, without limitation, alteration, modification, reproduction, distribution, or reverse engineering of such MOTOROLA software or exercise of rights in such MOTOROLA software is permitted. No license is granted by implication, estoppel or otherwise under MOTOROLA patent rights or copyrights.

## VII. Governing Law

This Warranty is governed by the laws of the State of Illinois, USA.

## Notes

# Model Numbering, Charts, and Specifications

## Portable Radio Model Numbering System

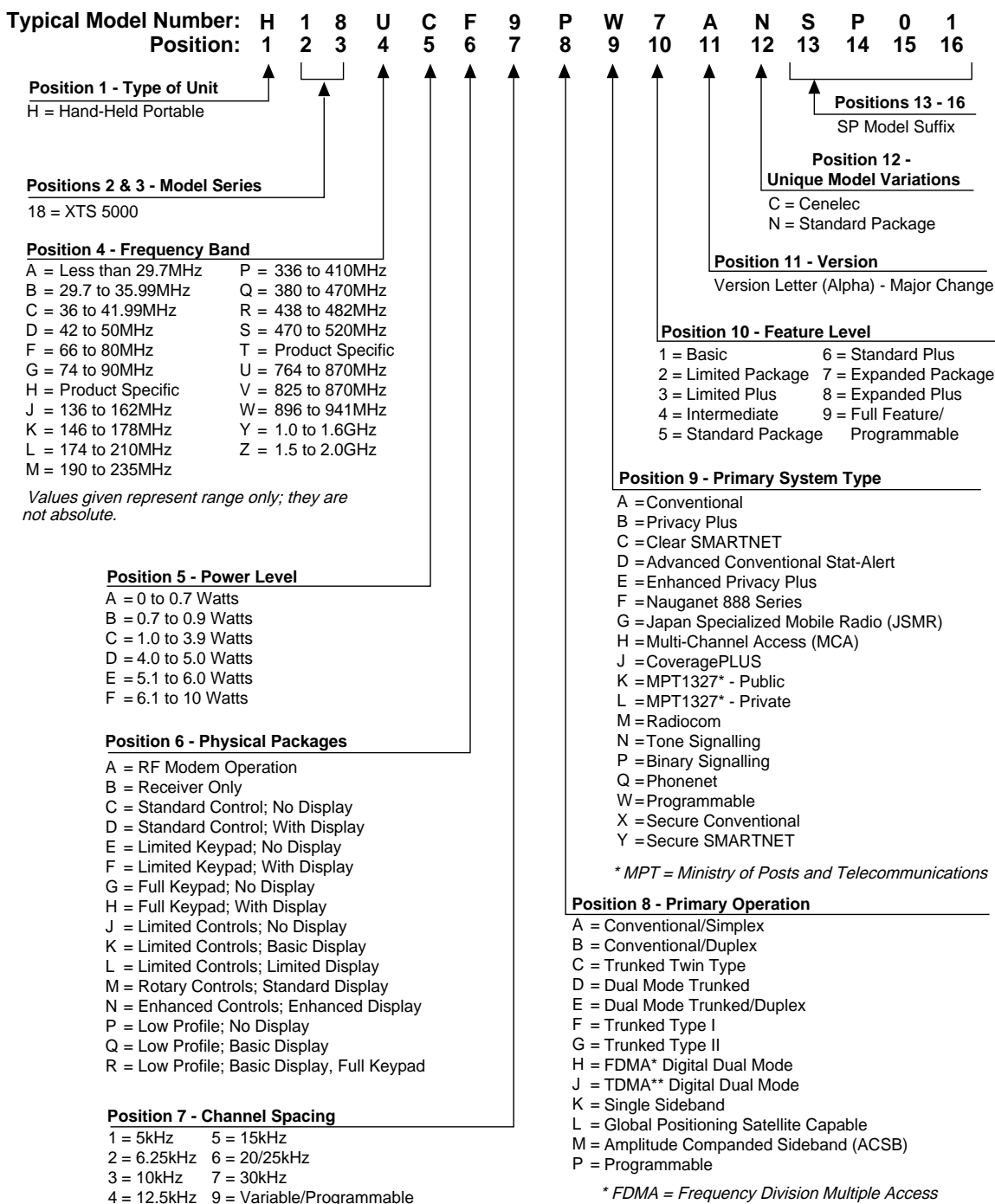

## ASTRO XTS 5000 VHF Model Chart

MODEL NUMBER			DESCRIPTION
		H18KEC9PW5AN	VHF 1-6 Watts ASTRO XTS 5000 Model I
		H18KEF9PW6AN	VHF 1-6 Watts ASTRO XTS 5000 Model II
		H18KEH9PW7AN	VHF 1-6 Watts ASTRO XTS 5000 Model III
ITEM NUMBER			DESCRIPTION
X	X	X	NLD8910_ Board, Transceiver (VHF)
X	X	X	NNTN4563_ or, Board, VOCON* NNTN4717_ Board, VOCON*
X	X	X	— Belt Clip Kit (Refer to the Basic Service Manual accessories appendix)
X	X	X	— Battery (Refer to <a href="#">Table 2-1</a> and <a href="#">Table 2-2 on page 2-1</a> )
X			NTN9682_ Kit, Front Cover, Model I
	X		NTN9681_ Kit, Front Cover, Model II
		X	NTN9680_ Kit, Front Cover, Model III
X	X	X	— Antenna, VHF (Refer to the Basic Service Manual accessories appendix)
X	X	X	0985973B02 Assembly, B+ Connector
X	X	X	1505579Z01 Cover, Accessory Connector
X			2685567D01 Assembly, VOCON Shield, Model I
	X		2685567D02 Assembly, VOCON Shield-Keypad, Model II
		X	2685567D03 Assembly, VOCON Shield-Keypad, Model III
X	X	X	2685220D08 Shield, RF (Transceiver) Board
X	X	X	2785219D01 Assembly, Casting
X	X	X	2885866A01 Connector, Compression, 26-Pin
X	X	X	3285900E01 Gasket, Antenna O-Ring
X	X	X	3205349Z03 Seal, Main
X	X	X	3205351Z02 Seal, B+
X	X	X	3285877B02 Seal, Port
X	X	X	3385873B01 Label, Port
	X	X	7285726C02 Module, LCD Display
	X	X	7585189D01 Pad, Display Locator
X	X	X	7585936D02 Pad, RF
X	X	X	7585139E01 Pad, Battery holder
	X		7585104D02 Keypad, Model II
		X	7585104D01 Keypad, Model III

**Notes:**

**X** = Item Included

- \* = The radio's model number, FLASHcode, Host code, and DSP code are required when placing an order for the VOCON Board.
- The model number and (sometimes) the FLASHcode can be found on the FCC label on the back of the radio.
  - The model number, Host code, DSP code, and (sometimes) the FLASHcode can be found by putting a Model II or III radio into the Test Mode.
  - The model number, Host code, DSP code, and FLASHcode can be found by using the Programming Cable (RKN4105\_ or RKN4106\_) and the CPS to read a Model I, II, or III radio.



## ASTRO XTS 5000 R (Ruggedized) VHF Model Chart

MODEL NUMBER							DESCRIPTION
H18KEC9PW5AN w/Q155FE Opt							Ruggedized VHF 1-6 Watts ASTRO XTS 5000 Model I
H18KEF9PW6AN w/Q155FF Opt							Ruggedized VHF 1-6 Watts ASTRO XTS 5000 Model II
H18KEH9PW7AN w/Q155FG Opt							Ruggedized VHF 1-6 Watts ASTRO XTS 5000 Model III
H18KEC9PW5AN w/Q155FS Opt							Ruggedized Yellow VHF 1-6 Watts ASTRO XTS 5000 Model I
H18KEF9PW6AN w/Q155FT Opt							Ruggedized Yellow VHF 1-6 Watts ASTRO XTS 5000 Model II
H18KEH9PW7AN w/Q155FU Opt							Ruggedized Yellow VHF 1-6 Watts ASTRO XTS 5000 Model III
ITEM NUMBER							DESCRIPTION
X	X	X	X	X	X	NLD8910_	Board, Transceiver (VHF)
X	X	X	X	X	X	NNTN4563_ or, NNTN4717_	Board, VOCON* Board, VOCON*
X	X	X	X	X	X	—	Belt Clip Kit (Refer to the Basic Service Manual accessories appendix)
X	X	X	X	X	X	—	Battery (Refer to <a href="#">Table 2-1</a> and <a href="#">Table 2-2 on page 2-1</a> )
X						NNTN4059_	Kit, Front Cover, Model I, Ruggedized
	X					NNTN4060_	Kit, Front Cover, Model II, Ruggedized
		X				NNTN4061_	Kit, Front Cover, Model III, Ruggedized
			X			NTN9685_	Kit, Yellow Front Cover, Model I, Ruggedized
				X		NTN9684_	Kit, Yellow Front Cover, Model II, Ruggedized
					X	NTN9683_	Kit, Yellow Front Cover, Model III, Ruggedized
X	X	X	X	X	X	—	Antenna, VHF (Refer to the Basic Service Manual accessories appendix)
X	X	X	X	X	X	0985973B02	Assembly, B+ Connector
X	X	X	X	X	X	1505579Z01	Cover, Accessory Connector
X			X			2685567D01	Assembly, VOCON Shield, Model I
	X			X		2685567D02	Assembly, VOCON Shield-Keypad, Model II
		X			X	2685567D03	Assembly, VOCON Shield-Keypad, Model III
X	X	X	X	X	X	2685220D08	Shield, RF (Transceiver) Board
X	X	X	X	X	X	2785219D04	Assembly, Ruggedized Casting
X	X	X	X	X	X	2885866A01	Connector, Compression, 26-Pin
X	X	X	X	X	X	3285900E01	Gasket, Antenna O-Ring
X	X	X	X	X	X	3205349Z03	Seal, Main
X	X	X	X	X	X	3205351Z02	Seal, B+
X	X	X	X	X	X	3285877B02	Seal, Port
X	X	X	X	X	X	3385873B01	Label, Port
	X	X		X	X	7285726C02	Module, LCD Display
	X	X		X	X	7585189D01	Pad, Display Locator
X	X	X	X	X	X	7585936D02	Pad, RF
X	X	X	X	X	X	7585139E01	Pad, Battery holder
X	X	X	X	X	X	3285688D01	Plug, Vacuum test port
	X			X		7585104D02	Keypad, Model II
		X			X	7585104D01	Keypad, Model III

**Notes:**

X = Item Included

\* = The radio's model number, FLASHcode, Host code, and DSP code are required when placing an order for the VOCON Board.

- The model number and (sometimes) the FLASHcode can be found on the FCC label on the back of the radio.
- The model number, Host code, DSP code, and (sometimes) the FLASHcode can be found by putting a Model II or III radio into the Test Mode.
- The model number, Host code, DSP code, and FLASHcode can be found by using the Programming Cable (RKN4105\_ or RKN4106\_) and the CPS to read a Model I, II, or III radio.

## ASTRO XTS 5000 UHF Range 1 Model Chart

MODEL NUMBER							DESCRIPTION	
H18QDC9PW5AN							UHF Range 1, 1-5 Watts ASTRO XTS 5000 Model I	
H18QDF9PW6AN							UHF Range 1, 1-5 Watts ASTRO XTS 5000 Model II	
H18QDH9PW7AN							UHF Range 1, 1-5 Watts ASTRO XTS 5000 Model III	
H18QCC9PW5AN							UHF Range 1, Low Power, 20 mW - 2 Watts ASTRO XTS 5000 Model I	
H18QCF9PW6AN							UHF Range 1, Low Power, 20 mW - 2 Watts ASTRO XTS 5000 Model II	
H18QCH9PW7AN							UHF Range 1, Low Power, 20 mW - 2 Watts ASTRO XTS 5000 Model III	
ITEM NUMBER							DESCRIPTION	
X	X	X					NLE4272_	Board, Transceiver (UHF)
			X	X	X		NLE4278_	Board, Transceiver (UHF) Low Power
X	X	X	X	X	X		NNTN4819_ or, NNTN4717_	Board, VOCON* Board, VOCON*
X	X	X	X	X	X		—	Belt Clip Kit (Refer to the Basic Service Manual accessories appendix)
X	X	X	X	X	X		—	Battery (Refer to <a href="#">Table 2-1</a> and <a href="#">Table 2-2 on page 2-1</a> )
X			X				NTN9682_	Kit, Front Cover, Model I
	X			X			NTN9681_	Kit, Front Cover, Model II
		X			X		NTN9680_	Kit, Front Cover, Model III
X	X	X	X	X	X		—	Antenna, UHF (Refer to the Basic Service Manual accessories appendix)
X	X	X	X	X	X		0985973B02	Assembly, B+ Connector
X	X	X	X	X	X		1505579Z01	Cover, Accessory Connector
X			X				2685567D01	Assembly, VOCON Shield, Model I
	X			X			2685567D02	Assembly, VOCON Shield-Keypad, Model II
		X			X		2685567D03	Assembly, VOCON Shield-Keypad, Model III
X	X	X	X	X	X		2685220D08	Shield, RF (Transceiver) Board
X	X	X	X	X	X		2785219D01	Assembly, Casting
X	X	X	X	X	X		2885866A01	Connector, Compression, 26-Pin
X	X	X	X	X	X		3285900E01	Gasket, Antenna O-Ring
X	X	X	X	X	X		3205349Z03	Seal, Main
X	X	X	X	X	X		3205351Z02	Seal, B+
X	X	X	X	X	X		3285877B02	Seal, Port
X	X	X	X	X	X		3385873B01	Label, Port
	X	X		X	X		7285726C03	Module, LCD Display
	X	X		X	X		7585189D01	Pad, Display Locator
X	X	X	X	X	X		7585936D04	Pad, RF
X	X	X	X	X	X		7585139E01	Pad, Battery holder
	X			X			7585104D02	Keypad, Model II
		X			X		7585104D01	Keypad, Model III

### Notes:

X = Item Included

- \* = The radio's model number, FLASHcode, Host code, and DSP code are required when placing an order for the VOCON Board.
- The model number and (sometimes) the FLASHcode can be found on the FCC label on the back of the radio.
  - The model number, Host code, DSP code, and (sometimes) the FLASHcode can be found by putting a Model II or III radio into the Test Mode.
  - The model number, Host code, DSP code, and FLASHcode can be found by using the Programming Cable (RKN4105\_ or RKN4106\_) and the CPS to read a Model I, II, or III radio.

## ASTRO XTS 5000 R (Ruggedized) UHF Range 1 Model Chart

MODEL NUMBER										DESCRIPTION	
H18QDC9PW5AN w/Q155FE Opt										Ruggedized UHF Range 1, 1-5 Watts ASTRO XTS 5000 Model I	
H18QDF9PW6AN w/Q155FF Opt										Ruggedized UHF Range 1, 1-5 Watts ASTRO XTS 5000 Model II	
H18QDH9PW7AN w/Q155FG Opt										Ruggedized UHF Range 1, 1-5 Watts ASTRO XTS 5000 Model III	
H18QDC9PW5AN w/Q155FS Opt										Ruggedized Yellow UHF Range 1, 1-5 Watts ASTRO XTS 5000 Model I	
H18QDF9PW6AN w/Q155FT Opt										Ruggedized Yellow UHF Range 1, 1-5 Watts ASTRO XTS 5000 Model II	
H18QDH9PW7AN w/Q155FU Opt										Ruggedized Yellow UHF Range 1, 1-5 Watts ASTRO XTS 5000 Model III	
H18QCC9PW5AN wQ155HW Opt										Ruggedized UHF R1, Low Pwr, 20 mW-2 Watts ASTRO XTS 5000 Model I	
H18QCF9PW6AN wQ155HX Opt										Ruggedized UHF R1, Low Pwr, 20 mW-2 Watts ASTRO XTS 5000 Model II	
H18QCH9PW7AN wQ155HY Opt										Ruggedized UHF R1, Low Pwr, 20 mW-2 Watts ASTRO XTS 5000 Model III	
										ITEM NUMBER	DESCRIPTION
X	X	X	X	X	X	X	X	X	X	NLE4272_	Board, Transceiver (UHF)
X	X	X	X	X	X	X	X	X	X	NLE4278_	Board, Transceiver (UHF) Low Power
X	X	X	X	X	X	X	X	X	X	NNTN4819_ or, NNTN4717_	Board, VOCON* Board, VOCON*
X	X	X	X	X	X	X	X	X	X	—	Belt Clip Kit (Refer to the Basic Service Manual accessories appendix)
X	X	X	X	X	X	X	X	X	X	—	Battery (Refer to <a href="#">Table 2-1</a> and <a href="#">Table 2-2 on page 2-1</a> )
X						X				NNTN4059_	Kit, Front Cover, Model I, Ruggedized
	X						X			NNTN4060_	Kit, Front Cover, Model II, Ruggedized
		X						X		NNTN4061_	Kit, Front Cover, Model III, Ruggedized
			X							NTN9685_	Kit, Yellow Front Cover, Model I, Ruggedized
				X						NTN9684_	Kit, Yellow Front Cover, Model II, Ruggedized
					X					NTN9683_	Kit, Yellow Front Cover, Model III, Ruggedized
X	X	X	X	X	X	X	X	X	X	—	Antenna, UHF (Refer to the Basic Service Manual accessories appendix)
X	X	X	X	X	X	X	X	X	X	0985973B02	Assembly, B+ Connector
X	X	X	X	X	X	X	X	X	X	1505579Z01	Cover, Accessory Connector
X			X			X				2685567D01	Assembly, VOCON Shield, Model I
	X			X			X			2685567D02	Assembly, VOCON Shield-Keypad, Model II
		X			X			X		2685567D03	Assembly, VOCON Shield-Keypad, Model III
X	X	X	X	X	X	X	X	X	X	2685220D08	Shield, RF (Transceiver) Board
X	X	X	X	X	X	X	X	X	X	2785219D04	Assembly, Ruggedized Casting
X	X	X	X	X	X	X	X	X	X	2885866A01	Connector, Compression, 26-Pin
X	X	X	X	X	X	X	X	X	X	3285900E01	Gasket, Antenna O-Ring
X	X	X	X	X	X	X	X	X	X	3205349Z03	Seal, Main
X	X	X	X	X	X	X	X	X	X	3205351Z02	Seal, B+
X	X	X	X	X	X	X	X	X	X	3285877B02	Seal, Port
X	X	X	X	X	X	X	X	X	X	3385873B01	Label, Port
	X	X		X	X		X	X		7285726C03	Module, LCD Display
	X	X		X	X		X	X		7585189D01	Pad, Display Locator
X	X	X	X	X	X	X	X	X	X	7585936D04	Pad, RF
X	X	X	X	X	X	X	X	X	X	7585139E01	Pad, Battery holder
X	X	X	X	X	X	X	X	X	X	3285688D01	Plug, Vacuum test port
	X			X			X			7585104D02	Keypad, Model II
		X						X		7585104D01	Keypad, Model III

**Notes:**

X = Item Included

\* = The radio's model number, FLASHcode, Host code, and DSP code are required when placing an order for the VOCON Board.

- The model number and (sometimes) the FLASHcode can be found on the FCC label on the back of the radio.
- The model number, Host code, DSP code, and (sometimes) the FLASHcode can be found by putting a Model II or III radio into the Test Mode.
- The model number, Host code, DSP code, and FLASHcode can be found by using the Programming Cable (RKN4105\_ or RKN4106\_) and the CPS to read a Model I, II, or III radio.

## ASTRO XTS 5000 UHF Range 2 Model Chart

MODEL NUMBER				DESCRIPTION
H18SDC9PW5AN				UHF Range 2, 1-5 Watts ASTRO XTS 5000 Model I
H18SDF9PW6AN				UHF Range 2, 1-5 Watts ASTRO XTS 5000 Model II
H18SDH9PW7AN				UHF Range 2, 1-5 Watts ASTRO XTS 5000 Model III
ITEM NUMBER				DESCRIPTION
X	X	X	NLE4273_	Board, Transceiver (UHF R2)
X	X	X	NNTN4717_	Board, VOCON*
X	X	X	—	Belt Clip Kit (Refer to the Basic Service Manual accessories appendix)
X	X	X	—	Battery (Refer to <a href="#">Table 2-1</a> and <a href="#">Table 2-2 on page 2-1</a> )
X			NTN9682_	Kit, Front Cover, Model I
	X		NTN9681_	Kit, Front Cover, Model II
		X	NTN9680_	Kit, Front Cover, Model III
X	X	X	—	Antenna, UHF (Refer to the Basic Service Manual accessories appendix)
X	X	X	0985973B01	Assembly, B+ Connector
X	X	X	1505579Z01	Cover, Accessory Connector
X			2685567D01	Assembly, VOCON Shield, Model I
	X		2685567D02	Assembly, VOCON Shield-Keypad, Model II
		X	2685567D03	Assembly, VOCON Shield-Keypad, Model III
X	X	X	2685220D02	Shield, RF (Transceiver) Board
X	X	X	2785219D01	Assembly, Casting
X	X	X	2885866A01	Connector, Compression, 26-Pin
X	X	X	3205082E96	Gasket, Antenna O-Ring
X	X	X	3205349Z03	Seal, Main
X	X	X	3205351Z02	Seal, B+
X	X	X	3285877B02	Seal, Port
X	X	X	3385873B01	Label, Port
	X	X	7285726C03	Module, LCD Display
	X	X	7585189D01	Pad, Display Locator
	X		7585104D02	Keypad, Model II
		X	7585104D01	Keypad, Model III

### Notes:

X = Item Included

\* = The radio's model number, FLASHcode, Host code, and DSP code are required when placing an order for the VOCON Board.

- The model number and (sometimes) the FLASHcode can be found on the FCC label on the back of the radio.
- The model number, Host code, DSP code, and (sometimes) the FLASHcode can be found by putting a Model II or III radio into the Test Mode.
- The model number, Host code, DSP code, and FLASHcode can be found by using the Programming Cable (RKN4105\_ or RKN4106\_) and the CPS to read a Model I, II, or III radio.

## ASTRO XTS 5000 R (Ruggedized) UHF Range 2 Model Chart

MODEL NUMBER							DESCRIPTION	
							H18SDC9PW5AN w/Q155FL Opt	Ruggedized UHF Range 2, 1-5 Watts ASTRO XTS 5000 Model I
							H18SDF9PW6AN w/Q155FM Opt	Ruggedized UHF Range 2, 1-5 Watts ASTRO XTS 5000 Model II
							H18SDH9PW7AN w/Q155FN Opt	Ruggedized UHF Range 2, 1-5 Watts ASTRO XTS 5000 Model III
							H18SDF9PW5AN w/Q155FZ Opt	Ruggedized Yellow UHF Range 2, 1-5 Watts ASTRO XTS 5000 Model I
							H18SDF9PW6AN w/Q155FZ Opt	Ruggedized Yellow UHF Range 2, 1-5 Watts ASTRO XTS 5000 Model II
							H18SDH9PW7AN w/Q155GA Opt	Ruggedized Yellow UHF Range 2, 1-5 Watts ASTRO XTS 5000 Model III
							ITEM NUMBER	DESCRIPTION
X	X	X	X	X	X		NLE4273_	Board, Transceiver (UHF R2)
X	X	X	X	X	X		NNTN4717_	Board, VOCON*
X	X	X	X	X	X		—	Belt Clip Kit (Refer to the Basic Service Manual accessories appendix)
X	X	X	X	X	X		—	Battery (Refer to <a href="#">Table 2-1</a> and <a href="#">Table 2-2 on page 2-1</a> )
X							NNTN4059_	Kit, Front Cover, Model I, Ruggedized
	X						NNTN4060_	Kit, Front Cover, Model II, Ruggedized
		X					NNTN4061_	Kit, Front Cover, Model III, Ruggedized
			X				NTN9685_	Kit, Yellow Front Cover, Model I, Ruggedized
				X			NTN9684_	Kit, Yellow Front Cover, Model II, Ruggedized
					X		NTN9683_	Kit, Yellow Front Cover, Model III, Ruggedized
X	X	X	X	X	X		—	Antenna, UHF (Refer to the Basic Service Manual accessories appendix)
X	X	X	X	X	X		0985973B02	Assembly, B+ Connector
X	X	X	X	X	X		1505579Z01	Cover, Accessory Connector
X			X				2685567D01	Assembly, VOCON Shield, Model I
	X			X			2685567D02	Assembly, VOCON Shield-Keypad, Model II
		X			X		2685567D03	Assembly, VOCON Shield-Keypad, Model III
X	X	X	X	X	X		2685220D02	Shield, RF (Transceiver) Board
X	X	X	X	X	X		2785219D04	Assembly, Ruggedized Casting
X	X	X	X	X	X		2885866A01	Connector, Compression, 26-Pin
X	X	X	X	X	X		3205082E96	Gasket, Antenna O-Ring
X	X	X	X	X	X		3205349Z03	Seal, Main
X	X	X	X	X	X		3205351Z02	Seal, B+ Ruggedized
X	X	X	X	X	X		3285877B02	Seal, Port
X	X	X	X	X	X		3385873B01	Label, Port
	X	X		X	X		7285726C03	Module, LCD Display
	X	X		X	X		7585189D01	Pad, Display Locator
	X			X			7585104D02	Keypad, Model II
		X			X		7585104D01	Keypad, Model III

**Notes:**

X = Item Included

\* = The radio's model number, FLASHcode, Host code, and DSP code are required when placing an order for the VOCON Board.

- The model number and (sometimes) the FLASHcode can be found on the FCC label on the back of the radio.
- The model number, Host code, DSP code, and (sometimes) the FLASHcode can be found by putting a Model II or III radio into the Test Mode.
- The model number, Host code, DSP code, and FLASHcode can be found by using the Programming Cable (RKN4105\_ or RKN4106\_) and the CPS to read a Model I, II, or III radio.

## ASTRO XTS 5000 700–800 MHz Model Chart

MODEL NUMBER			DESCRIPTION
H18UCC9PW5AN			700/800 MHz 1-3 Watts ASTRO XTS 5000 Model I
	H18UCF9PW6AN		700/800 MHz 1-3 Watts ASTRO XTS 5000 Model II
		H18UCH9PW7AN	700/800 MHz 1-3 Watts ASTRO XTS 5000 Model III
ITEM NUMBER			DESCRIPTION
X	X	X	NUF3577_ Board, Transceiver (700/800 MHz)
X	X	X	NTN9564_ or, Board, VOCON* NNTN4717_ Board, VOCON*
X	X	X	— Belt Clip Kit (Refer to the Basic Service Manual accessories appendix)
X	X	X	— Battery (Refer to <a href="#">Table 2-1</a> and <a href="#">Table 2-2</a> on page 2-1)
X			NTN9682_ Kit, Front Cover, Model I
	X		NTN9681_ Kit, Front Cover, Model II
		X	NTN9680_ Kit, Front Cover, Model III
X	X	X	— Antenna, 700/800 MHz (Refer to the Basic Service Manual accessories appendix)
X	X	X	0985973B02 Assembly, B+ Connector
X	X	X	1505579Z01 Cover, Accessory Connector
X			2685567D01 Assembly, VOCON Shield, Model I
	X		2685567D02 Assembly, VOCON Shield-Keypad, Model II
		X	2685567D03 Assembly, VOCON Shield-Keypad, Model III
X	X	X	2685220D08 Shield, RF (Transceiver) Board
X	X	X	2785219D01 Assembly, Casting
X	X	X	2885866A01 Connector, Compression, 26-Pin
X	X	X	3285900E01 Gasket, Antenna O-Ring
X	X	X	3205349Z03 Seal, Main
X	X	X	3205351Z02 Seal, B+
X	X	X	3285877B02 Seal, Port
X	X	X	3385873B01 Label, Port
	X	X	7285726C01 or, Module, LCD Display (for use only with the NTN9564_ VOCON board) 7285726C02 Module, LCD Display (for use only with the NNTN4717_ VOCON board)
	X	X	7585189D01 Pad, Display Locator
X	X	X	7585936D04 Pad, RF
X	X	X	7585139E01 Pad, Battery holder
	X		7585104D02 Keypad, Model II
		X	7585104D01 Keypad, Model III

### Notes:

**X** = Item Included

- \* = The radio's model number, FLASHcode, Host code, and DSP code are required when placing an order for the VOCON Board.
- The model number and (sometimes) the FLASHcode can be found on the FCC label on the back of the radio.
  - The model number, Host code, DSP code, and (sometimes) the FLASHcode can be found by putting a Model II or III radio into the Test Mode.
  - The model number, Host code, DSP code, and FLASHcode can be found by using the Programming Cable (RKN4105\_ or RKN4106\_) and the CPS to read a Model I, II, or III radio.

## ASTRO XTS 5000 R (Ruggedized) 700–800 MHz Model Chart

MODEL NUMBER							DESCRIPTION
							Ruggedized 700/800 MHz 1-3 Watts ASTRO XTS 5000 Model I
							Ruggedized 700/800 MHz 1-3 Watts ASTRO XTS 5000 Model II
							Ruggedized 700/800 MHz 1-3 Watts ASTRO XTS 5000 Model III
							Ruggedized Yellow 700/800 MHz 1-3 Watts ASTRO XTS 5000 Model I
							Ruggedized Yellow 700/800 MHz 1-3 Watts ASTRO XTS 5000 Model II
							Ruggedized Yellow 700/800 MHz 1-3 Watts ASTRO XTS 5000 Model III
ITEM NUMBER							DESCRIPTION
X	X	X	X	X	X		NUF3577_
X	X	X	X	X	X		NTN9564_ or, NNTN4717_
X	X	X	X	X	X		—
X	X	X	X	X	X		—
X							NNTN4059_
	X						NNTN4060_
		X					NNTN4061_
			X				NTN9685_
				X			NTN9684_
					X		NTN9683_
X	X	X	X	X	X		—
X	X	X	X	X	X		0985973B02
X	X	X	X	X	X		1505579Z01
X			X				2685567D01
	X			X			2685567D02
		X			X		2685567D03
X	X	X	X	X	X		2685220D08
X	X	X	X	X	X		2785219D04
X	X	X	X	X	X		2885866A01
X	X	X	X	X	X		3285900E01
X	X	X	X	X	X		3205349Z03
X	X	X	X	X	X		3205351Z02
X	X	X	X	X	X		3285877B02
X	X	X	X	X	X		3385873B01
	X	X		X	X		7285726C01 or, 7285726C02
	X	X		X	X		7585189D01
X	X	X	X	X	X		7585936D04
X	X	X	X	X	X		7585139E01
X	X	X	X	X	X		3285688D01
	X			X			7585104D02
		X			X		7585104D01

**Notes:**

X = Item Included

\* = The radio's model number, FLASHcode, Host code, and DSP code are required when placing an order for the VOCON Board.

- The model number and (sometimes) the FLASHcode can be found on the FCC label on the back of the radio.
- The model number, Host code, DSP code, and (sometimes) the FLASHcode can be found by putting a Model II or III radio into the Test Mode.
- The model number, Host code, DSP code, and FLASHcode can be found by using the Programming Cable (RKN4105\_ or RKN4106\_) and the CPS to read a Model I, II, or III radio.



## Specifications for VHF Radios

All specifications are per Telecommunications Industries Association TIA-603 unless otherwise noted.

GENERAL		RECEIVER		TRANSMITTER	
<b>FCC Designation:</b>	AZ489FT3804	<b>Frequency Range:</b>	136-174 MHz	<b>Frequency Range:</b>	136-174 MHz
<b>Temperature Range:</b>		<b>Bandwidth:</b>	38 MHz	<b>RF Power:</b>	
<b>Operating:</b>	-30°C to +60°C	<b>Usable Sensitivity (typical) (12 dB SINAD):</b>	0.20 µV	136-174 MHz:	1-6 Watts
<b>Storage:</b>	-40°C to +85°C	<b>Intermodulation (typical):</b>	-75 dB	<b>Frequency Stability (typical) (-30 to +60°C; 25°C ref.):</b>	±0.0002%
<b>Power Supply:</b> Nickel-Cadmium Battery (NiCd) or Nickel-Metal-Hydride Battery (NiMH) or Lithium-Ion Battery (Li-Ion)		<b>Selectivity (typical): (25/30 kHz Channel): (12.5 kHz Channel):</b>	-75 dB -63 dB	<b>Emission (typical conducted):</b>	-75 dBc
<b>Battery Voltage:</b>		<b>Spurious Rejection (typical):</b>	-75 dB	<b>FM Hum and Noise (typical) (Companion Receiver):</b>	25 kHz -48 dB 12.5 kHz -42 dB
<b>Nominal:</b>	7.5 Vdc	<b>Frequency Stability (-30+60°C; 25°C reference):</b>	±0.0002%	<b>Distortion (typical):</b>	1.0% (typical)
<b>Range:</b>	6 to 9 Vdc	<b>Rated Audio:</b>	500 mW	<b>Modulation Limiting:</b>	25 kHz chnls ±5.0 kHz 12.5 kHz chnls ±2.5 kHz
<b>Transmit Current Drain (Typical):</b>	2100 mA	<b>FM Hum and Noise (typical):</b>	25 kHz -55 dB 12.5 kHz -49 dB	<b>ACPR (typical):</b>	25 kHz -73 dBc 12.5 kHz -63 dBc
<b>Receive Current Drain (Rated Audio):</b>	240 mA	<b>Distortion (typical):</b>	1.5%	<b>Emissions Designators:</b>	20K0F1E, 16K0F3E, 11K0F3E, 8K10F1D, and 8K10F1E
<b>Standby Current Drain:</b>	80 mA	<b>Channel Spacing:</b>	12.5/25 kHz		
<b>Recommended Battery:</b>					
<b>Smart NiMH:</b>	NNTN4435_				
<b>or Ultra-High-Capacity NiCd:</b>	NTN8294_				
<b>or Extended-Capacity NiMH:</b>	NTN8293_				
<b>or Li-Ion:</b>	NTN8610_				
<b>or Ultra-High-Capacity NiCd FM:</b>	NTN8295_*				
<b>or Ultra-High-Capacity NiMH FM:</b>	NTN8299_*				
<b>Optional FM (Factory Mutual) Battery:</b>					
* FM Intrinsicly Safe: Class I, II, III, Division 1, Groups C, D,E, F, and G. FM Non-incendive: Class 1, Division 2, Groups A, B, C, and D.					
<b>Dimensions (H x W x D):</b>					
Note: 2.44" = width at PTT; 2.34" = width at bottom; 1.83" = depth at speaker; 0.97" = depth at keypad					
<b>Without Battery (Radio Only):</b>					
6.58" x 2.44" x 1.83"/6.58" x 2.34" x 0.97"					
(167.13 mm x 61.90 mm x 46.42 mm/ 167.13 mm x 59.49 mm x 24.56 mm)					
<b>With Battery:</b>					
6.58" x 2.44" x 1.83"/6.58" x 2.34" x 1.65"					
(167.13 mm x 61.90 mm x 46.42 mm/ 167.13 mm x 59.49 mm x 41.97 mm)					
<b>Weight: (w/ Antenna):</b>					
<b>Less Battery:</b>	14.10 oz (383 gm)				
<b>With Ultra-High Cap. NiCd:</b>	25.19 oz (693 gm)				
<b>With Li-Ion:</b>	20.41 oz (583 gm)				
<b>With Ultra-High Cap. NiMH:</b>	23.45 oz (644 gm)				
<b>With Extended- Cap. NiMH:</b>	24.04 oz (682 gm)				

Specifications subject to change without notice.



## Specifications for UHF Range 1 Radios

All specifications are per Telecommunications Industries Association TIA-603 unless otherwise noted.

GENERAL		RECEIVER		TRANSMITTER	
<b>FCC Designation:</b>	AZ489FT4855	<b>Frequency Range:</b>	380-470 MHz	<b>Frequency Range:</b>	380-470 MHz
<b>Temperature Range:</b>		<b>Bandwidth:</b>	90 MHz	<b>RF Power:</b>	
<b>Operating:</b>	-30°C to +60°C	<b>Usable Sensitivity (typical)</b>		<b>380-470 MHz:</b>	1-5 Watts
<b>Storage:</b>	-40°C to +85°C	<b>(12 dB SINAD):</b>	0.25 µV	<b>Frequency Stability (typical)</b>	
<b>Power Supply:</b> Nickel-Cadmium Battery (NiCd)		<b>Intermodulation (typical):</b>	-75 dB	<b>(-30 to +60°C; 25°C ref.):</b>	±0.0002%
or Nickel-Metal-Hydride Battery (NiMH)		<b>Selectivity (typical):</b>		<b>Emission (typical conducted):</b>	-70 dBc
or Lithium-Ion Battery (Li-Ion)		<b>(25/30 kHz Channel):</b>	-78 dB	<b>FM Hum and Noise (typical)</b>	
<b>Battery Voltage:</b>		<b>(12.5 kHz Channel):</b>	-60 dB	<b>(Companion Receiver):</b>	25 kHz -45 dB
<b>Nominal:</b>	7.5 Vdc	<b>Spurious Rejection (typical):</b>	-80 dB	12.5 kHz -40 dB	
<b>Range:</b>	6 to 9 Vdc	<b>Frequency Stability</b>		<b>Distortion (typical):</b>	1.5% (typical)
<b>Transmit Current Drain (Typical):</b>	2100 mA	<b>(-30+60°C; 25°C reference):</b>	±0.0002%	<b>Modulation Limiting:</b>	25 kHz chnls ±5.0 kHz
<b>Receive Current Drain (Rated Audio):</b>	240 mA	<b>Rated Audio:</b>	500 mW	12.5 kHz chnls ±2.5 kHz	
<b>Standby Current Drain:</b>	80 mA	<b>FM Hum and Noise (typical):</b>		<b>ACPR (typical):</b>	25 kHz -77 dBc
<b>Recommended Battery:</b>		25 kHz -54 dB		12.5 kHz -62 dBc	
<b>Smart NiMH:</b>	NNTN4435	12.5 kHz -45 dB		<b>Emissions Designators:</b>	
<b>or Ultra-High-Capacity NiCd:</b>	NTN8294	<b>Distortion (typical):</b>	1.0%	20K0F1E, 16K0F3E, 11K0F3E, 8K10F1D, and	
<b>or Extended-Capacity NiMH:</b>	NTN8293	<b>Channel Spacing:</b>	12.5/25 kHz	8K10F1E	
<b>or Li-Ion:</b>	NTN8610				
<b>or Ultra-High-Capacity NiCd FM:</b>	NTN8295*				
<b>or Ultra-High-Capacity NiMH FM:</b>	NTN8299*				
<b>Optional FM (Factory Mutual) Battery:</b>					
* FM Intrinsically Safe.					
<b>Dimensions (H x W x D):</b>					
Note: 2.44" = width at PTT; 2.34" = width at bottom; 1.83" = depth at speaker; 0.97" = depth at keypad					
<b>Without Battery (Radio Only):</b>					
6.58" x 2.44" x 1.83"/6.58" x 2.34" x 0.97"					
(167.13 mm x 61.90 mm x 46.42 mm/					
167.13 mm x 59.49 mm x 24.56 mm)					
<b>With Battery:</b>					
6.58" x 2.44" x 1.83"/6.58" x 2.34" x 1.65"					
(167.13 mm x 61.90 mm x 46.42 mm/					
167.13 mm x 59.49 mm x 41.97 mm)					
<b>Weight: (w/ Antenna):</b>					
<b>Less Battery:</b>	14.10 oz (383 gm)				
<b>With Ultra-High Cap. NiCd:</b>	25.19 oz (693 gm)				
<b>With Li-Ion:</b>	20.41 oz (583 gm)				
<b>With Ultra-High Cap. NiMH:</b>	23.45 oz (644 gm)				
<b>With Extended- Cap. NiMH:</b>	24.04 oz (682 gm)				

Specifications subject to change without notice.

## Specifications for UHF Range 2 Radios

All specifications are per Telecommunications Industries Association TIA-603 unless otherwise noted.

GENERAL		RECEIVER		TRANSMITTER	
<b>FCC Designation:</b>	<b>AZ489FT4864</b>	<b>Frequency Range:</b>	450-520 MHz	<b>Frequency Range:</b>	450-520 MHz
<b>Temperature Range:</b>		<b>Bandwidth:</b>	70 MHz	<b>RF Power:</b>	
<b>Operating:</b>	-30°C to +60°C	<b>Usable Sensitivity (typical)</b>		<b>450-520 MHz:</b>	1-5 Watts
<b>Storage:</b>	-40°C to +85°C	<b>(12 dB SINAD):</b>	0.19 µV	<b>Frequency Stability (typical)</b>	
<b>Power Supply:</b> Nickel-Cadmium Battery (NiCd)		<b>Intermodulation (typical):</b>	-77 dB	<b>(-30 to +60°C; 25°C ref.):</b>	±0.0002%
or Nickel-Metal-Hydride Battery (NiMH)		<b>Selectivity (typical):</b>		<b>Emission (typical conducted):</b>	-75 dBc
or Lithium-Ion Battery (Li-Ion)		<b>(25/30 kHz Channel):</b>	-79 dB	<b>FM Hum and Noise (typical)</b>	
<b>Battery Voltage:</b>		<b>(12.5 kHz Channel):</b>	-65 dB	<b>(Companion Receiver):</b>	25 kHz -45 dB
<b>Nominal:</b>	7.5 Vdc	<b>Spurious Rejection (typical):</b>	-85 dB	12.5 kHz -40 dB	
<b>Range:</b>	6 to 9 Vdc	<b>Frequency Stability</b>		<b>Distortion (typical):</b>	1.5% (typical)
<b>Transmit Current Drain (Typical):</b>	2100 mA	<b>(-30+60°C; 25°C reference):</b>	±0.0002%	<b>Modulation Limiting:</b>	25 kHz chnls ±5.0 kHz
<b>Receive Current Drain (Rated Audio):</b>	240 mA	<b>Rated Audio:</b>	500 mW	12.5 kHz chnls ±2.5 kHz	
<b>Standby Current Drain:</b>	80 mA	<b>FM Hum and Noise (typical):</b>		<b>ACPR (typical):</b>	25 kHz -77 dBc
<b>Recommended Battery:</b>		25 kHz -53 dB		12.5 kHz -63 dBc	
<b>Smart NiMH:</b>	NNTN4435	12.5 kHz -45 dB		<b>Emissions Designators:</b>	
or <b>Ultra-High-Capacity NiCd:</b>	NTN8294	<b>Distortion (typical):</b>	1.0%	20K0F1E, 16K0F3E, 11K0F3E, 8K10F1D, and	
or <b>Extended-Capacity NiMH:</b>	NTN8293	<b>Channel Spacing:</b>	12.5/25 kHz	8K10F1E	
or <b>Li-Ion:</b>	NTN8610				
or <b>Ultra-High-Capacity NiCd FM:</b>	NTN8295*				
or <b>Ultra-High-Capacity NiMH FM:</b>	NTN8299*				
<b>Optional FM (Factory Mutual) Battery:</b>					
* FM Intrinsically Safe.					
<b>Dimensions (H x W x D):</b>					
Note: 2.44" = width at PTT; 2.34" = width at bottom; 1.83" = depth at speaker; 0.97" = depth at keypad					
<b>Without Battery (Radio Only):</b>					
6.58" x 2.44" x 1.83"/6.58" x 2.34" x 0.97"					
(167.13 mm x 61.90 mm x 46.42 mm/					
167.13 mm x 59.49 mm x 24.56 mm)					
<b>With Battery:</b>					
6.58" x 2.44" x 1.83"/6.58" x 2.34" x 1.65"					
(167.13 mm x 61.90 mm x 46.42 mm/					
167.13 mm x 59.49 mm x 41.97 mm)					
<b>Weight: (w/ Antenna):</b>					
<b>Less Battery:</b>	13.0 oz (368 gm)				
<b>With Ultra-High Cap. NiCd:</b>	25.19 oz (693 gm)				
<b>With Li-Ion:</b>	20.41 oz (583 gm)				
<b>With Ultra-High Cap. NiMH:</b>	23.45 oz (644 gm)				
<b>With Extended-Cap. NiMH:</b>	24.04 oz (682 gm)				

Specifications subject to change without notice.

## Specifications for 700–800 MHz Radios

All specifications are per Telecommunications Industries Association TIA-603 unless otherwise noted.

GENERAL	RECEIVER	TRANSMITTER
<b>FCC Designation:</b> AZ489FT5806 <b>Temperature Range:</b> <b>Operating:</b> -30°C to +60°C <b>Storage:</b> -40°C to +85°C  <b>Power Supply:</b> Nickel-Cadmium Battery (NiCd) or Nickel-Metal-Hydride Battery (NiMH) or Lithium-Ion Battery (Li-Ion)  <b>Battery Voltage:</b> <b>Nominal:</b> 7.5 Vdc <b>Range:</b> 6 to 9 Vdc  <b>Transmit Current Drain (Typical):</b> 1400 mA <b>Receive Current Drain (Rated Audio):</b> 240 mA <b>Standby Current Drain:</b> 80 mA  <b>Recommended Battery:</b> <b>Ultra-High-Capacity Smart NiCd:</b> HNN9031_ or <b>Ultra-High-Capacity NiCd:</b> NTN8294_ or <b>Extended-Capacity NiMH:</b> NTN8293_ or <b>Li-Ion:</b> NTN8610_ or <b>Ultra-High-Capacity NiCd FM:</b> NTN8295_* or <b>Ultra-High-Capacity NiMH FM:</b> NTN8299_* <b>Optional FM (Factory Mutual) Battery:</b> * FM Intrinsically Safe: Class I, II, III, Division 1, Groups C, D, E, F, and G. FM Non-incendive: Class 1, Division 2, Groups A, B, C, and D.  <b>Dimensions (H x W x D):</b> Note: 2.44" = width at PTT; 2.34" = width at bottom; 1.83" = depth at speaker; 0.97" = depth at keypad <b>Without Battery (Radio Only):</b> 6.58" x 2.44" x 1.83"/6.58" x 2.34" x 0.97" (167.13 mm x 61.90 mm x 46.42 mm/ 167.13 mm x 59.49 mm x 24.56 mm) <b>With Battery:</b> 6.58" x 2.44" x 1.83"/6.58" x 2.34" x 1.65" (167.13 mm x 61.90 mm x 46.42 mm/ 167.13 mm x 59.49 mm x 41.97 mm)  <b>Weight: (w/ Antenna):</b> <b>Less Battery:</b> 14.10 oz (383 gm) <b>With Ultra-High Cap. NiCd:</b> 25.19 oz (693 gm) <b>With Li-Ion:</b> 20.41 oz (583 gm) <b>With Ultra-High Cap. NiMH:</b> 23.45 oz (644 gm) <b>With Extended- Cap. NiMH:</b> 24.04 oz (682 gm)	<b>Frequency Range:</b> <b>700 MHz:</b> 764 to 767; 773 to 776 MHz <b>800 MHz:</b> 851 to 870 MHz  <b>Bandwidth:</b> 106 MHz  <b>Usable Sensitivity (typical) (12 dB SINAD):</b> 0.20 µV  <b>Intermodulation (typical):</b> -75 dB  <b>Selectivity (typical):</b> <b>(25/30 kHz Channel):</b> -72 dB <b>(12.5 kHz Channel):</b> -63 dB  <b>Spurious Rejection (typical):</b> -75 dB  <b>Frequency Stability (-30+60°C; 25°C reference):</b> ±0.00015%  <b>Rated Audio:</b> 500 mW  <b>FM Hum and Noise (typical):</b> 25 kHz -48 dB 12.5 kHz -40 dB  <b>Distortion (typical):</b> 1.5%  <b>Channel Spacing:</b> 12.5/25 kHz	<b>Frequency Range:</b> <b>700 MHz:</b> 764 to 767; 773 to 776; 794 to 797; 803 to 806 MHz <b>800 MHz:</b> 806 to 824; 851 to 870 MHz  <b>RF Power:</b> <b>764-806 MHz:</b> 2.5 Watts <b>806-870 MHz:</b> 3 Watts  <b>Frequency Stability (typical) (-30 to +60°C; 25°C ref.):</b> ±0.00015%  <b>Emission (typical conducted):</b> -75 dBc  <b>FM Hum and Noise (typical) (Companion Receiver):</b> 25 kHz -45 dB 12.5 kHz -40 dB  <b>Distortion (typical):</b> 1.5% (typical)  <b>Modulation Limiting:</b> 25 kHz chnls ±5.0 kHz 12.5 kHz chnls ±2.5 kHz  <b>Emissions Designators:</b> 20K0F1E, 16K0F3E, 11K0F3E, 8K10F1D, and 8K10F1E

Specifications subject to change without notice.

## Notes

---

# Chapter 1 Introduction

## 1.1 General

This manual includes all the information needed to maintain peak product performance and maximum working time for the ASTRO XTS 5000 radio. This detailed level of service (component level) is typical of the service performed by some service centers, self-maintained customers, and distributors.

Use this manual in conjunction with the *ASTRO XTS 5000 VHF/UHF Range 1/700–800 MHz Digital Portable Radios Basic Service Manual* (Motorola part number 6881094C28), which can help in troubleshooting a problem to a particular printed circuit (PC) board.

Conduct the basic performance checks outlined in the basic service manual first to verify the need to analyze the radio and to help pinpoint the functional problem area. In addition, you will become familiar with the radio test mode of operation, which is a helpful tool. If any basic receive or transmit parameters fail to be met, the radio should be aligned according to the radio alignment procedure.

Included in other areas of this manual are functional block diagrams, detailed theory of operation, troubleshooting charts and waveforms, schematics, and parts lists. You should become familiar with these sections to aid in determining circuit problems. Also included are component location diagrams to aid in locating individual circuit components and some IC diagrams, which identify some convenient probe points.

[“Chapter 3, Theory of Operation,” on page 3-1](#), contains detailed descriptions of the operations of many circuits. Once you locate the problem area, review the troubleshooting flowchart for that circuit to fix the problem.

---

## 1.2 Notations Used in This Manual

Throughout the text in this publication, you will notice the use of warnings, cautions, and notes. These notations are used to emphasize that safety hazards exist, and care must be taken and observed.

**NOTE:** An operational procedure, practice, or condition that is essential to emphasize.



**Caution**

CAUTION indicates a potentially hazardous situation which, if not avoided, might result in equipment damage.



**WARNING**

**WARNING** indicates a potentially hazardous situation which, if not avoided, could result in death or injury.



**DANGER**

**DANGER** indicates an imminently hazardous situation which, if not avoided, will result in death or injury.

---

## Chapter 2 Radio Power

This chapter provides a detailed circuit description of the power distribution of an ASTRO XTS 5000 radio.

### 2.1 General

In the ASTRO XTS 5000 radio, power (B+) is distributed to two boards: the transceiver (RF) board and the VOCON board (see [Figure 2-1 on page 2-2](#) for UHF Range 1 (R1) and 700–800 MHz, and [Figure 2-2 on page 2-2](#) for VHF). In the case of a secure model radio, B+ is also supplied to the encryption module.

Power for the radio is provided through a battery supplying a nominal 7.5 Vdc directly to the transceiver. The following battery types and capacities are available:

*Table 2-1. Conventional Batteries*

Part Number	Description
NTN8294	1525 NiCd, Ultra-High Capacity
NTN8295	1525 NiCd High-Capacity Factory Mutual (FM) Intrinsically Safe
NTN8297	1525 NiCd High-Capacity Factory Mutual (FM) Intrinsically Safe, Rugged
NTN8299	1750 NiMH Ultra-Capacity FM
NTN8610	1650 Lithium Ion
NTN8923	1800 NiMH Ultra-Capacity
NTN9177	Battery Holder, Clamshell, Black
NTN9183	Battery Holder, Clamshell, Orange
RNN4006	3000 NiMH
RNN4007	3000 NiMH FM

*Table 2-2. Smart Batteries*

Part Number	Description
HNN9031	1525 NiCd Smart
HNN9032	1525 NiCd Smart FM
NNTN4435_R	1800 mAh, NiMH Smart
NNTN4436	1750 NiMH Smart FM (VHF use only)

---

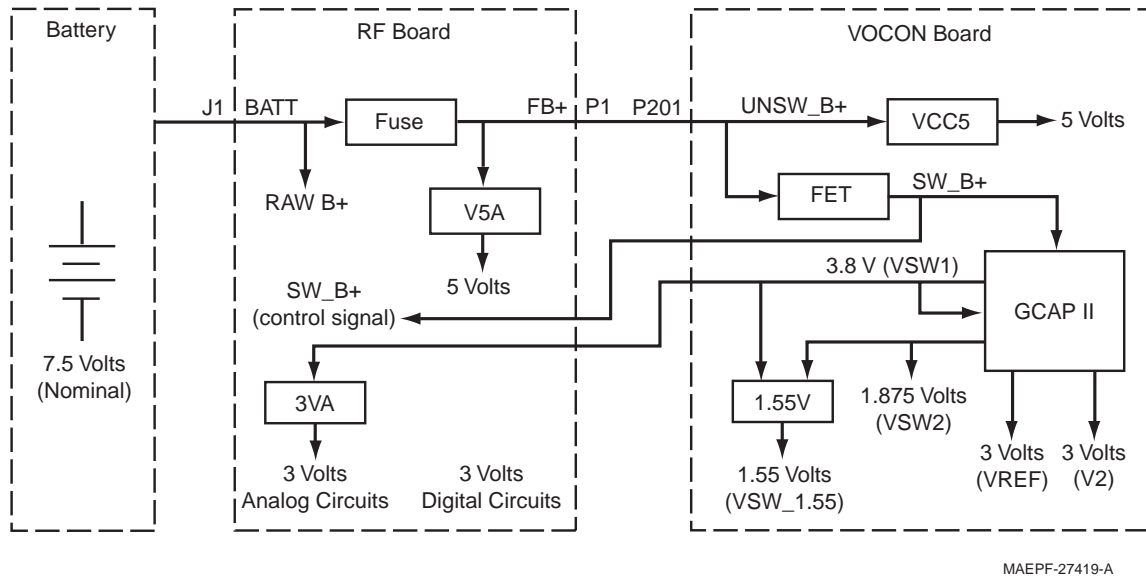

Figure 2-1. DC Power Distribution—UHF Range 1 and 700–800 MHz Radios

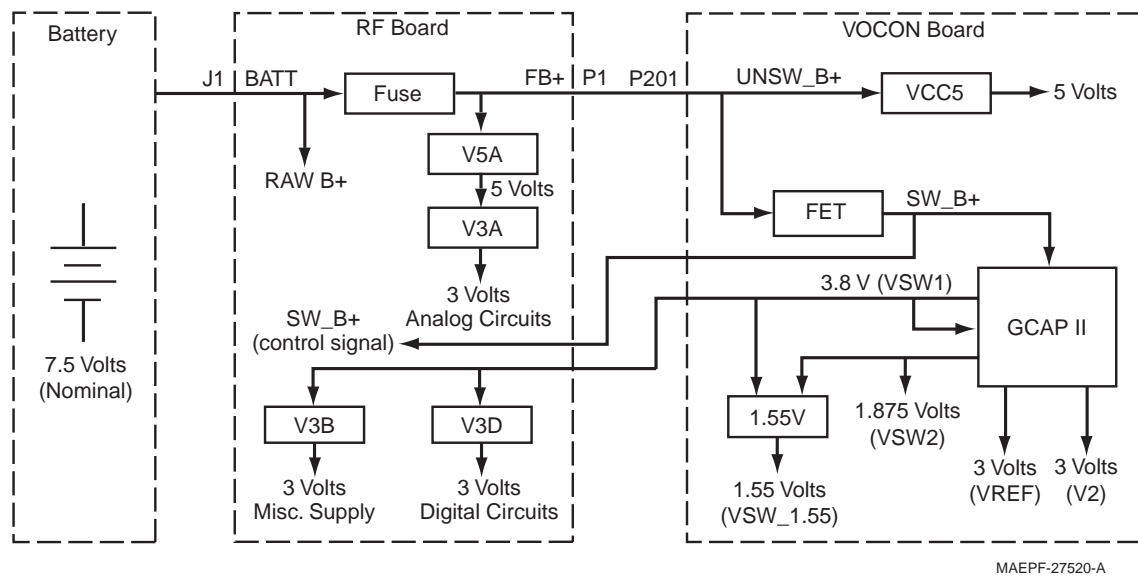

Figure 2-2. DC Power Distribution—VHF and Range 2 Radios

B+ from the battery is electrically switched to most of the radio, rather than routed through the On/Off/volume control knob, S1. The electrical switching of B+ supports a *keep-alive* mode. Under software control, even when the On/Off/volume control knob has been turned to the Off position, power remains on until the MCU completes its power-down, at which time the radio is physically powered down.



## 2.2 DC Power Routing—Transceiver Board

**NOTE:** Refer to [Table 8-1, “List of Transceiver Schematics and Board Overlays,”](#) on page 8-1 for a listing of schematics showing the transceiver board DC power routing components.

Connector J1, the B-plus assembly, connects the battery to the transceiver board. Capacitors C1, C2, and C3 provide protection against momentary breaks at the B-plus connector due to contact bounce when the radio is dropped.

**UHF R1 and 700–800 MHz:** Components C5, E4, C7, and E1 form a power-line filter for signal RAWB+, which supplies battery voltage to the transmitter PA.

**UHF R2 and VHF:** Component E1 forms a power-line filter for signal RAWB+, which supplies battery voltage to the transmitter PA.

Transistor Q1, controlled by signal SWB+ (SB+ for VHF) from the VOCON board, turns on XB+, which supplies to the 5-V linear regulator and TX\_ALC block.

Fuse F901 and filter C11, L1, C10 (C14, L1, C13 for VHF) supply fused B-plus to the VOCON board. In turn, the VOCON board supplies VSW1, regulated 3.8 Vdc, from the Global Control Audio and Power (GCAP) switching regulator to the XCVR. Switch Q99 (Q503 for VHF), controlled by SWB+, turns on V38 to the XCVR 3-V linear regulators. The XCVR regulated power supplies are summarized in [Table 2-3](#).

Table 2-3. Transceiver Voltage Regulators

Ref. Desig.	IC Name	Output Signal Name	Description
U1	LP2989	V5A	Regulated 5.0 Vdc
U2	LP3985	V3D	Regulated 3.0 Vdc digital
U3	LP3985	V3A	UHF R1 and 700–800 MHz: Regulated 3.0 Vdc analog for the RX FE <b>UHF R2 and VHF:</b> Regulated 3.0 Vdc analog for synthesizer
U5	LP3985	V3B	<b>UHF R2 and VHF only:</b> Regulated 3.0 Vdc miscellaneous supply

## 2.3 DC Power Routing—VOCON Board

**NOTE:** Refer to [Table 8-2, “List of VOCON Schematics and Board Overlays,”](#) on page 8-1 for a listing of schematics showing the VOCON board DC power routing components.

Raw B+, or unswitched B+, (UNSW\_B+) is routed to connector P1 on the transceiver board, and then on to P201 on the VOCON board. Here the UNSW B+ is forwarded to the radio’s control top On/Off/volume knob through connector J101 and a flex circuit, as well as to regulator U505 (VCC5).

The On/Off/volume knob controls B+SENSE to Q502, which in turn controls Q501. Transistor Q501 is a solid-state power switch that provides SW B+ to the VOCON board, the audio PA, the GCAP II IC (via GCAP\_B+), and back to the transceiver board.

In the case of a secure radio model, SW B+ and UNSW B+ are also supplied to the encryption module through connector J701.

Transistor Q501 is also under the control of the microcontroller unit (MCU) via Vref from U501. This allows the MCU to follow an orderly power-down sequence when it senses that B+SENSE is off. This sense is provided through MECH\_SW\_BAR (inverted B+SENSE, see Q508).

The digital circuits in the VOCON board are powered from regulators located in the GCAP II IC (U501), an external 5 Vdc regulator (VCC5, U505), and an external 1.55 Vdc regulator (VSW\_1.55V, on NNTN4717 VOCON kit only). The GCAP II IC provides three supplies: VSW1, VSW2, and V2. These regulators are software programmable. Table 2-4 lists the supply voltages and the circuits that use these voltages.

Table 2-4. VOCON Board DC Power Distribution

Supply Name	Output Voltage	Supply Type	Unprogrammed Output Voltage	Circuits Supplied
UNSW_B+	9 to 6 Vdc 7.5 Vdc nominal	Battery	N/A	VCC5 input Mechanical switch Power switch (FET) Secure module Real-time clock battery
SW_B+	9 to 6 Vdc 7.5 Vdc nominal	Battery	N/A	VSW1 input (GCAP) Audio power amplifier Side connector SW_B+ to transceiver board GCAP IC Secure module USB circuitry
VCC5	5Vdc	Linear Regulator	N/A	Smart battery circuitry Int. / ext. microphone bias Audio preamplifier Flipper IC Keypad / Display LEDs
VSW1	3.8 Vdc	Switching regulator software programmable	3.2 Vdc	3-V regulators (RF) VSW2 input V2 input
VSW2	1.8 Vdc	Switching regulator software programmable	2.2 Vdc	Patriot core FLASH IC SRAM Display (only on NTN9564 VOCON board)
V2	3 Vdc* 2.9 Vdc**	Linear regulator software programmable	2.775 Vdc	Patriot I/O ring Flipper IC EEPOT Display 16.8 MHz buffer
VSW_1_55V	1.55 Vdc	Linear regulator	N/A	Patriot core (only on NNTN4717 VOCON board)

\* = NTN9564, NNTN4563 & NNTN4819 VOCON kits

\*\* = NNTN4717 VOCON kit

## Chapter 3 Theory of Operation

This chapter provides a detailed circuit description of the ASTRO XTS 5000 transceiver and VOCON boards. When reading the theory of operation, refer to the appropriate schematic and component location diagrams located in the back of this manual. This detailed theory of operation can help isolate the problem to a particular component.

The ASTRO XTS 5000 radio is a dual-mode (digital/analog), microcontroller-based transceiver incorporating a digital signal processor (DSP). The microcontroller handles the general radio control, monitors status, and processes commands input from the keypad or other user controls. The DSP processes the typical analog signals, and generates the standard signaling digitally to provide compatibility with existing analog systems. In addition, the DSP provides digital modulation techniques, utilizing voice encoding techniques with error correction schemes. This provides the user with enhanced range and audio quality, all in a reduced bandwidth channel requirement. It allows embedded signaling, which can mix system information and data with digital voice to support a multitude of system features.

The three ASTRO XTS 5000 radio models (I, II, and III) are available in the VHF (136 to 174 MHz), UHF Range 1 (380 to 470 MHz), UHF Range 2 (450 to 520 MHz), and 700–800 MHz (764 to 870 MHz) frequency bands.

The ASTRO XTS 5000 radio (Figure 3-1) consists of the following:

- Band-dependent transceiver (RF) board
- Vocoder/controller (VOCON) board
- Universal flex assembly
- Display and keypad assemblies (Models II and III only)
- Encryption board (secure models only)

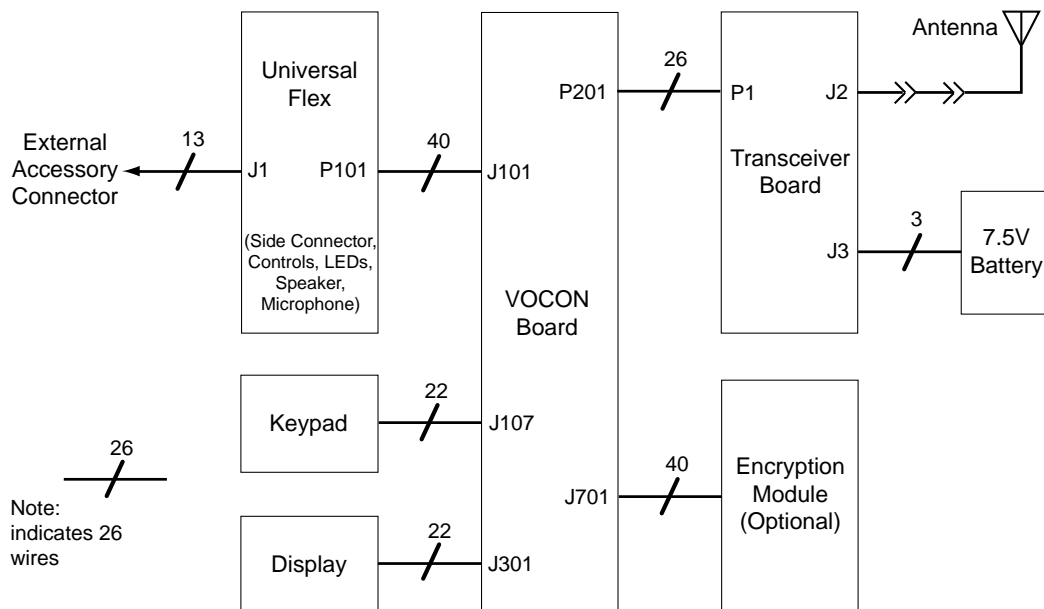

Figure 3-1. XTS 5000 Overall Block Diagram

### 3.1 Transceiver Board

The transceiver (XCVR) board performs the transmitter and receiver functions necessary to translate between voice and data from the VOCON board and the modulated radio-frequency (RF) carrier at the antenna. The transceiver board contains all the radio's RF circuits for the following major components:

- Receiver
- Transmitter
- Frequency Generation Unit (FGU)

Figure 3-2 illustrates the VHF transceiver board block diagram while Figure 3-3 on page 3-3 illustrates the transceiver UHF Range 1 and 700–800 MHz transceiver block diagrams.

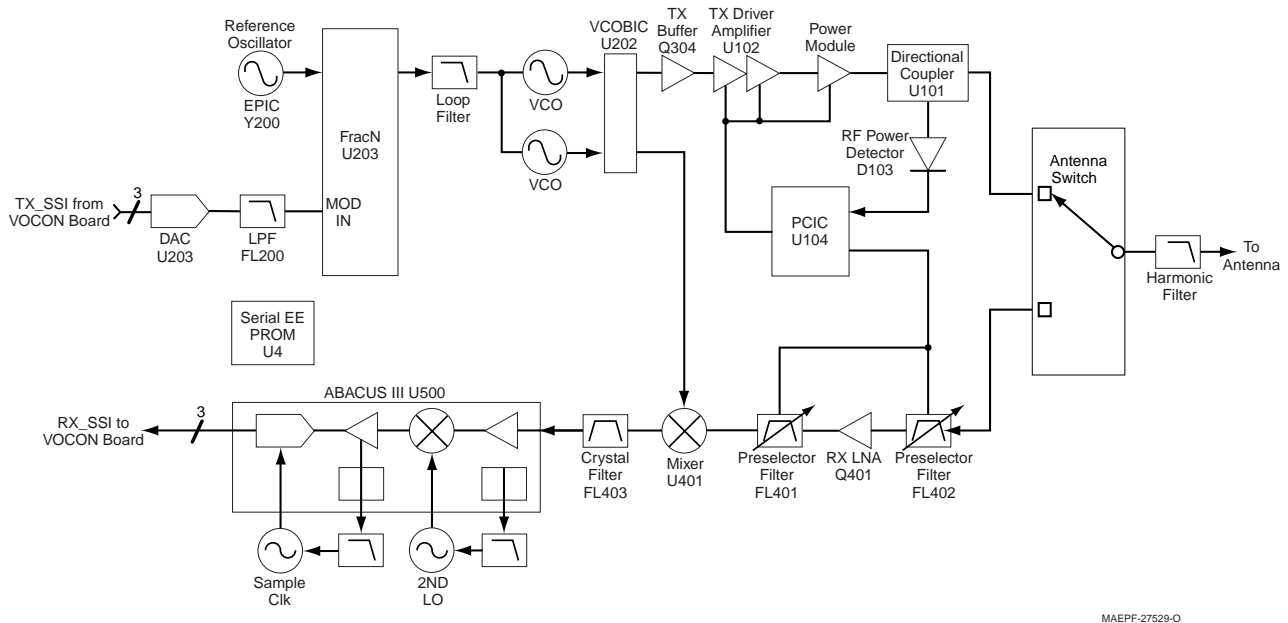

Figure 3-2. Transceiver (VHF) Block Diagram (Power and Control Omitted)

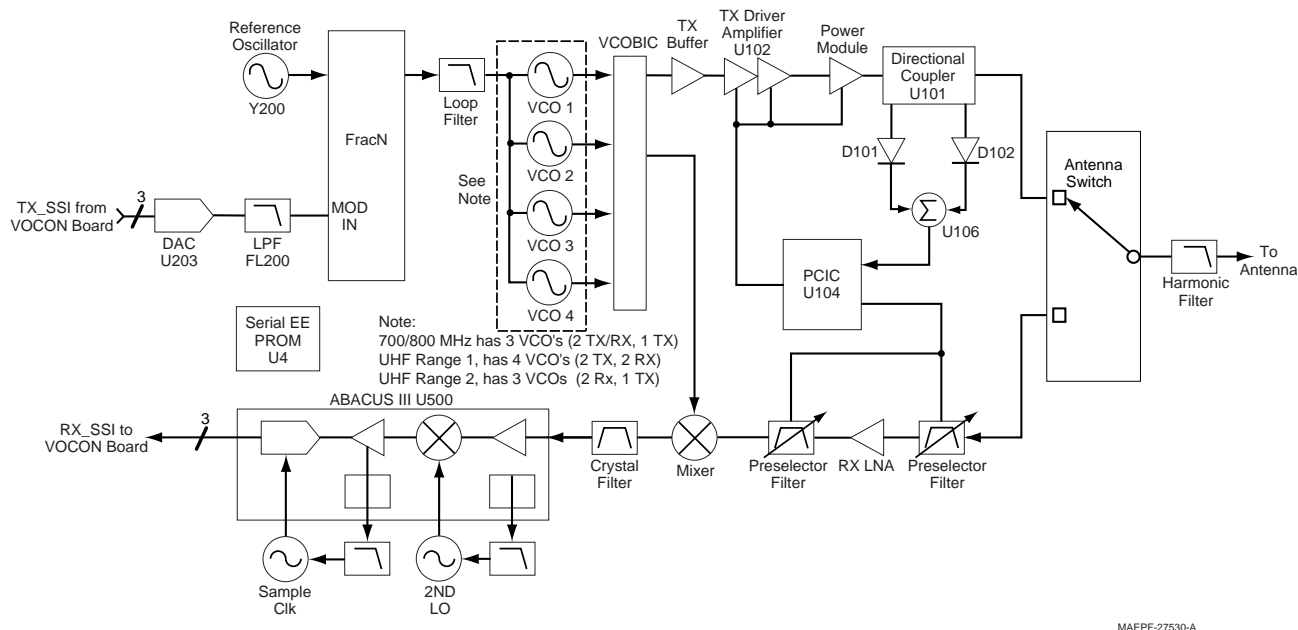

Figure 3-3. Transceiver (UHF Range 1, UHF Range 2 and 700–800 MHz) Block Diagram (Power and Control Omitted)

### 3.1.1 Interconnections

This section describes the various interconnections for the transceiver board.

#### 3.1.1.1 Battery Connector J3

Battery connector J3 consists of three gold-plated contacts on the printed circuit board that mate with a B-plus connector assembly. Signal descriptions are in [Table 3-1](#).

Table 3-1. Battery Connector J3

Pin No.	Signal	Description
1	BATT	Battery positive terminal, nominally 7.5 Vdc
2	BSTAT	Battery status, from battery to VOCON
3	BAT_RTN	Battery negative terminal, tied to PCB ground

#### 3.1.1.2 VOCON Connector P1

VOCON connector P1 (located on the XCVR board) consists of 26 gold-plated pads for the 26-pin compression connector, and one plated tool hole (pin 27) used for connector alignment. This is a digital interface carrying DC power, control, and data between the XCVR and VOCON boards. P1 connects through the compression connector to P201 on the VOCON board.

Table 3-2 lists the connector pins, their signals, and functions. SPI refers to serial peripheral interface, which is the control bus from the microprocessor. SSI is the serial synchronous interface bus for data to and from the DSP. There is a RX SSI bus for demodulated data from the receiver and a TX SSI bus for modulation data to the transmitter.

Table 3-2. VOCON Connector P1

Pin No.	VOCON Signal	XCVR Signal	XCVR I/O	Type	Description
1	UNSW_B+	FUB+	O	dc	Fused B+ to VOCON
2	UNSW_B+	FUB+	O	dc	Fused B+ to VOCON
3	LOCK_DET*	LOCK	O	status	FGU lock detect
4	TX_SSI_DATA	TXTD	O	ssi	TX SSI data
5	SSI_CLK	RXCK	O	ssi	RX SSI clock
6	SSI_FSYNC	SSFS	O	ssi	RX SSI frame sync
7	16.8MHz	F168	O	RF	16.8 MHz reference clock
8	SW_B+	SWB+	I	dc	Switch control
9	TX_SSI_FSYNC	TXFS	I	ssi	TX SSI frame sync
10	TX_SSI_CLK	TXCK	I	ssi	TX SSI clock
11	GND	GND			
12	RX_SSI_DATA	RXDO	O	ssi	RX SSI data
13	ABACUS3_CS	ABCS	I	ssi	SPI Abacus chip select
14	GND	GND			
15	VSW1	VSW1	I	dc	Regulated 3.8 V
16	SPI_CLK_A	SPCK	I	spi	SPI clock
17	SPI_MISO_A	MISO	O	spi	SPI data out
18	EEPROM_SEL*	EECS	I	spi	SPI EEPROM chip select
19	TX_INHIBIT	TXINH	I	control	TX inhibit control for secure
20	GND	GND			
21	BAT_STATUS	BSTAT	O	dc	Battery status
22	GND	GND			
23	SPI_MOSI_A	MOSI	I/O	spi	SPI data I/O
24	UNI_CS	USEL	I	spi	SPI universal chip select
25	AD_CS	ADCS	I	spi	SPI ADC chip select
26	POR*	RSTL	I/O	control	asynchronous reset, active low

### 3.1.1.3 Antenna Port J2

Antenna port J2 is a surface-mount, miniature coaxial connector for the antenna cable.

### 3.1.1.4 Serial EEPROM

The serial, electrostatically erasable, programmable, read-only memory (EEPROM), U907 in VHF and 700–800 MHz or U4 in UHF Range 1, holds all of the transceiver tuning data. This allows transceivers to be tuned in the factory and installed in the field without retuning.

### 3.1.1.5 Power Conditioning Components

DC power-conditioning components include zener diodes, capacitors, ferrite beads, a power inductor, and the fuse. Diodes VR1 and VR2 provide over-voltage protection. Ferrite beads (designated E1, etc.) and capacitors suppress electromagnetic interference from the transceiver. The power-line filter consisting of L1, C13, and C14 for VHF radios or L1, C10, and C11 for UHF Range 1 and 700–800 MHz radios, suppresses digital noise from the VOCON board switching power supplies that could degrade the transmitter spectral purity.

Pass transistor Q1 switches the battery voltage to the transceiver when control signal SWB+ or SB+ from the VOCON board is asserted high. This increases the transceiver's immunity to conducted interference that might be present on SWB+ or SB+, such as from switching voltage regulators on the VOCON board.

Ground clips G1 through G12 make contact between the transceiver board ground and the radio chassis. The chassis connection is a necessary electrical reference point to complete the antenna circuit path. Shields SH101 through SH700 and the tool hole appear on the schematic to show their connection to ground.

## 3.1.2 Receiver

The XTS 5000 transceiver has a dual-conversion superheterodyne receiver. [Figure 3-4](#) illustrates the major receiver components:

- Receiver Front End
- Receiver Back End

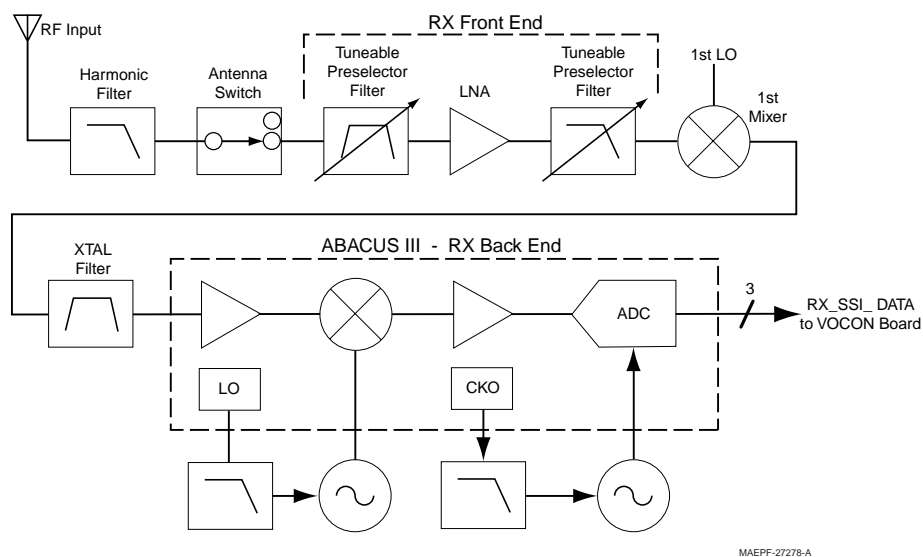

Figure 3-4. Receiver Block Diagram

### 3.1.2.1 Receiver Front End

**NOTE:** Refer to [Table 8-1, “List of Transceiver Schematics and Board Overlays,”](#) on page 8-1 for a listing of receiver front end schematics.

The receiver front end tunes to the desired channel and down converts the RF signal to the first intermediate frequency (IF). Channel selection is by way of a tunable local oscillator, RXLO, from the FGU.

The receiver front end consists of a preselector filter, an RF amplifier, a second preselector, mixer, and an IF crystal filter. VHF, UHF Range 1 and UHF Range 2 radios also contain a switchable attenuator between the antenna switch and the first preselector filter. The RF amplifier is a discrete RF transistor with associated circuitry. The mixer is a double-balanced, active mixer IC, coupled by transformers. The receiver (RX) local oscillator (LO) is provided by the FGU.

#### 3.1.2.1.1 Preselector Filters

**VHF, UHF Range 1, and UHF Range 2:** The receiver front end uses two discrete, tunable, bandpass filters to achieve its required out-of-band rejection. The first preselector filter precedes the RF amplifier, while the second preselector filter follows the RF amplifier. DAC2, from the PCIC, is used to simultaneously tune both preselector filters by applying voltage to the varactors.

**700–800 MHz:** The receiver front end uses two, multi-layer, ceramic, tunable, bandpass filters to achieve its required out-of-band rejection. The first preselector filter, FL401, precedes the discrete RF amplifier. To tune the center frequency of the first filter, voltage from port DAC1 is applied to pin 3 of FL401. Pin 3 connects to the surface-mounted varactor diodes placed on each filter. A second identical filter, FL402, follows the discrete RF amplifier. The second filter is tuned by applying voltage from port DAC2 to pin 3 of FL402. Capacitors C409 and C410 are RF bypasses. Capacitors C400 and C411 are used to filter out noise from the DAC1 and DAC2 control lines.

#### 3.1.2.1.2 LNA (Low-Noise Amplifier)

The XTS 5000 radio uses a discrete transistor for the low-noise amplifier (Q428 in VHF, Q430 in UHF Range 1, Q428 in UHF Range 2, and Q401 in 700–800 MHz). A feedback network between the collector and base improves stability and gain balance across the frequency band. Input and output LC networks match the LNA impedance to 50 ohms.

A diode limiter (D722 in VHF, D400 in UHF Range 1, D722 in UHF Range 2, and D401 in 700-800 MHz) protects the amplifier damage by strong input signals.

#### 3.1.2.1.3 Mixer

The mixer (U45 in VHF, U470 in UHF Range 1, U451 in UHF Range 2 and U401 in 700–800 MHz) down-converts the received RF to the first intermediate frequency (IF). The IF is 44.85 MHz for VHF, 73.35 MHz for UHF Range 1 and UHF Range 2, and 109.65 MHz for 7/800 MHz. High-side LO injection is used for VHF and 700 MHz, low-side for the UHF bands and 800 MHz. Transformers are used as baluns to convert signals from single-ended to balanced at pins MI, MIX, LO, and LOX. An output transformer converts the balanced signal at pins MO and MOX to a single-ended output.

#### 3.1.2.1.4 IF Filter

The IF filter (FL451 in VHF, FL490 in UHF Range 1, FL451 in UHF Range 2, and FL403 in 700–800 MHz) is a leadless, surface-mount, 3-pole, quartz crystal filter. This narrow bandpass filter gives the radio its adjacent-channel and alternate-channel rejection performance.

Input and output LC networks match the filter impedance to 50 ohms. Exceptions are the VHF and UHF Range 2, where the output is matched to 50 ohms, but the input is not.



### 3.1.2.2 Receiver Back End

The receiver back end, which consists of the Abacus III (AD9874 IF digitizing subsystem) IC and its associated circuitry, processes the down-converted IF signal to produce digital data for final processing by the VOCON DSP.

**NOTE:** Refer to [Table 8-1, "List of Transceiver Schematics and Board Overlays,"](#) on page 8-1 for a listing of receiver back end schematics.

#### 3.1.2.2.1 Abacus III IC U500

The AD9874 ([Figure 3-5](#)) is a general-purpose, IF subsystem that digitizes a low-level 10–300 MHz IF input with a bandwidth up to 270 kHz. The output of the Abacus III IC is SSI data to the VOCON.

The signal chain of the AD9874 consists of a low-noise amplifier, a mixer, a bandpass sigma-delta A/D converter, and a decimation filter with programmable decimation factor. An automatic gain control (AGC) circuit provides the AD9874 with 12 dB of continuous gain adjustment. The high dynamic range and inherent anti-aliasing provided by the bandpass sigma-delta converter allow the AD9874 to cope with blocking signals 80 dB stronger than the desired signal.

Auxiliary blocks include frequency synthesizers for the second LO and sampling clock LO, as well as an SPI port. The second LO uses a discrete external loop filter and VCO. The clock oscillator has an external loop filter and resonator.

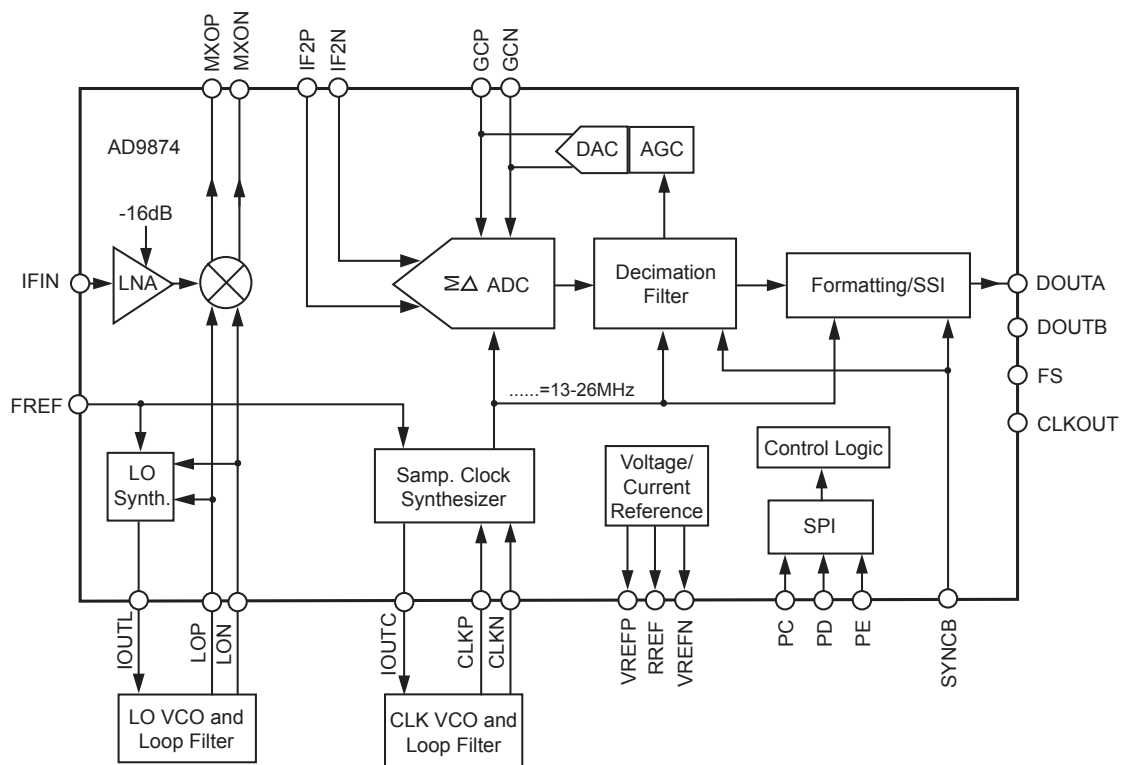

MAEPF-27412-0

Figure 3-5. Abacus III (AD9874) Functional Block Diagram (from data sheet)

**VHF:** Input signal RXIF is the 44.8 MHz IF from crystal filter FL451 in the receiver front end. Components C547 and L542 match the input impedance from 50 ohms at the RXIF to the Abacus input IFIN.

**UHF Range 1:** Input signal RXIF is 73.35 MHz. Components L547 and C547 match the input impedance to 50 ohms.

**UHF Range 2:** Input signal RXIF is 73.35 MHz. L542, C515, and C547 match the Abacus input to 50 Ohms.

**700–800 MHz:** Input signal RXIF is the 109.65 MHz IF from crystal filter FL403 in the receiver front end. Components L547 and C542 match the input impedance from 50 ohms at RXIF to approximately 420 ohms in parallel with a 1 pF capacitance at the Abacus input IFIN. Formatted SSI data is output to the VOCON board on ports FS, DOUTA, and CLKOUT.

#### 3.1.2.2.2 Second Local Oscillator

The second LO is controlled by the Abacus LO synthesizer, which mixes with IFIN to produce a 2.25 MHz final IF. The external VCO consists of Q502 and its bias network and frequency-determining elements. Signal FREF is the 16.8 MHz reference from the FGU. Darlington transistor Q501 with C550 and R501 form an active power-line filter.

**VHF:** The second LO frequency is 42.6 MHz by default, or 47.1 MHz in special cases as needed to avoid radio self-quieters. The loop filter is composed of R507, C558, C559, and C503.

**UHF Range 1:** The second LO frequency is 71.1 MHz by default or 75.6 MHz in special cases as needed to avoid radio self-quieters. The loop filter is composed of R551, C558, C559, R552, and C512.

**UHF Range 2:** The 2nd LO frequency is 71.1 Mhz. C558, R507, and C559 form the loop filter.

**700–800 MHz:** The second LO frequency is 107.4 MHz by default or 111.9 MHz in special cases as needed to avoid radio self-quieters. The loop filter is composed of R507, C558, C559, R505, and C512.

#### 3.1.2.2.3 Sampling Clock Oscillator

The Abacus sampling clock synthesizer operates at 18 MHz = 8 x 2.25 MHz. The VCO uses an internal transistor and external resonator. The resonator is composed of L503, C535, and D501.

**VHF:** The loop filter is composed of R514, C536, C570, and C571.

**UHF Range 1 and 700–800 MHz:** The loop filter is composed of R514, C570, and C571.

**UHF Range 2:** C503, C536, R415, C570, and C571 form the loop filter.

### 3.1.3 Transmitter

The transmitter takes modulated RF from the FGU and amplifies it to the radio's rated output power to produce the modulated transmitter carrier at the antenna.

**NOTE:** Refer to [Table 8-1, "List of Transceiver Schematics and Board Overlays,"](#) on page 8-1 for a listing of transmitter-related schematics that will aid in the following discussion.

The transmitter ([Figure 3-6 on page 3-9](#)) consists of an RF driver IC that receives its input signal from the voltage-controlled oscillator (VCO) and a high-power output transistor. Transmitter power is controlled by a power-control IC (PCIC) that senses the output of a directional coupler and adjusts PA control voltages to maintain a constant power level. The signal passes through an antenna switch and harmonic filter to the antenna.

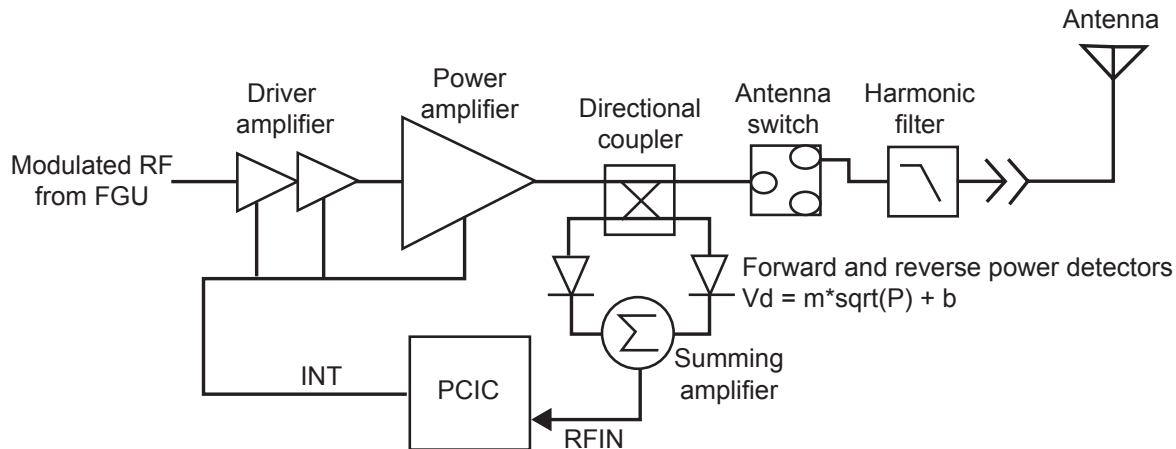

MAEPF-27408-O

Figure 3-6. Transmitter Block Diagram

### 3.1.3.1 Power Distribution

To minimize voltage drop to the power amplifiers, net RAWB+ connects to power module Q107 and the second stage of driver amplifier U102 through components having minimal series resistance—ferrite beads and chokes only. During receive, no RF or DC bias is applied, and leakage current through U102 and Q107 is less than 100 microamps. The first stage of U102 uses less than 50 mA and is supplied by TX7V, which is switched on during TX, and switched off during RX or whenever TXINH, the transmitter inhibit control line, is high.

**VHF:** At a transmitter power of 6 Watts, the radio consumes approximately 2000 mA. Bias TX7V is controlled by transistors Q101, Q102, Q103, and Q106.

**UHF Range 1 and Range 2:** At the rated transmitter power of 5 Watts, the radio consumes approximately 2000 mA. Bias TX7V is controlled by transistors Q101, Q102, Q103, and Q106.

**700–800 MHz:** At a transmitter power of 3 Watts, the radio consumes approximately 1200 mA. Bias TX7V is controlled by transistors Q101, Q102, Q103, and Q107.

### 3.1.3.2 Driver Amplifier

The driver amplifier IC (U102) contains two LDMOS FET amplifier stages and two internal resistor bias networks. Pin 16 is the RF input. Modulated RF from the FGU, at a level of +3 dBm  $\pm$ 2 dB, is coupled through a blocking capacitor to the gate of FET-1. An LC interstage matching network connects the first stage output VD1 to the second stage input G2. The RF output from the drain of FET-2 is pin 6 (RFOUT1). Gain control is provided by a voltage applied to pin 1 (VCNTRL). Typical output power is about +27 dBm (500 mW) with VCNTRL at 5.0 V.

**VHF:** L109 and C113 are the interstage matching network. Components C108–C111 and L106–L107 match the output impedance to maximize power transfer to Q107; capacitor C107 is a DC block.

**UHF Range 2:** L109 and C113 are the interstage matching network. Components C108–C111 and L105, L107, and L108 match the output impedance to maximize power transfer to Q107.

**UHF Range 1 and 700–800 MHz:** L109 and C116 are the interstage matching network. Components L105 and C110 match the output impedance to 50 ohms; capacitor C107 is a DC block.

### 3.1.3.3 Power Amplifier Transistor Q107

The power amplifier transistor, Q107, is an LDMOS FET housed in a high-power, surface-mount, ring package. To prevent thermal damage, it is essential that the heat sink of the power module be held in place against the radio chassis. The input impedance-matching network uses discrete inductors and capacitors. The low-pass output matching network uses both transmission lines and lumped LCs. Drain bias is applied through E101 and L101. Gain is dynamically controlled by adjusting the gate bias. The gate is insulated from the drain and source so that gate bias current is essentially zero.

**VHF:** The input and output impedance-matching networks consist of L112–L114 and C137–C140. Gate bias is applied through R105, R106, and L108.

**UHF Range 2:** The input and output impedance-matching networks consist of L113, L114 and C137, C139, C140, C149, and C151.

Gate bias is applied through R105, R106, and L720.

**UHF Range 1 and 700–800 MHz:** The input impedance-matching network is L106, L107, C108, and C109. A transmission-line structure and C137, C111, and C112 form the output-matching network. Gate bias applied through R106 and L110.

### 3.1.3.4 Directional Coupler

A directional coupler senses the transmitter forward and reverse power as control signals in the transmitter's automatic level control (ALC) loop. Isolated ports are terminated with external resistors.

**VHF and UHF Range 1:** The directional coupler consists of three embedded transmission lines.

**UHF Range 1 and 700–800 MHz:** The directional coupler is U101, a low-loss, bidirectional coupler.

### 3.1.3.5 Antenna Switch

**NOTE:** Refer to [Table 8-1, "List of Transceiver Schematics and Board Overlays,"](#) on page 8-1 for a listing of schematics that will aid in the following discussion.

The antenna switch is a single-pole, double-throw, positive-intrinsic-negative (PIN) diode, transmit/receive (T/R) antenna switch. Forward DC bias turn the diodes ON, reverse or zero bias turns them OFF.

**VHF and UHF Range 2:** PIN diodes D707 and D717 form a narrow-band, quarter-wave, T/R switch. In transmit mode, both diodes are forward-biased, and the signal goes from the transmitter to the antenna through the low resistance of the series PIN diode, while the low resistance of the shunt diode shorts the receiver. In receive mode, neither diode is biased and both behave as small-value capacitors, creating a high blocking impedance, in effect disconnecting the transmitter circuitry from the antenna.

**UHF Range 1:** Diodes D701 and D702 form a broadband switch. Inductors L706 and L707 resonate with the OFF diode parasitic capacitance to improve isolation.

**700–800 MHz:** PIN diodes D701 and D702 form a narrow-band, quarter-wave, T/R switch. When the PIN diodes are OFF, parallel inductors L706 and L707 resonate with the diode parasitic capacitance to increase isolation at the signal frequency.

The switch control circuit consists of transistors Q101, Q103, Q106, and associated resistors. The input signals are TXINH from the VOCON board and RXH (RX for VHF) from the PCIC. When TXINH is low and RXH (RX for VHF) is high, the switch is in the receive state. When TXINH and RXH (RX for VHF) are low, the switch is in its transmitter state. When TXINH is held high, the radio is inhibited from transmitting. This is a secure-module control feature.

### 3.1.3.6 Harmonic Filter

The harmonic filter is a high-power, low-loss, low-pass filter. Its purpose is to suppress transmitter harmonics. The filter also improves receiver out-of-band rejection. Shield SH700 must be in place to achieve the required stop band rejection.

**VHF:** The harmonic filter uses discrete components. The pass band is up to 190 MHz, and the stop band is above 260 MHz.

**UHF Range 1:** The harmonic filter is discrete, the pass band is up to 470 MHz, and the stop band is above 760 MHz.

**UHF Range 2:** The harmonic filter uses discrete components. The pass band is up to 595 MHz, and the stop band is above 900 MHz.

**700–800 MHz:** The harmonic filter uses both discrete components and transmission lines. The pass band is up to 870 MHz, and the stop band is above 1500 MHz.

### 3.1.3.7 RF Detectors D101 and D102

Two Schottky diodes, D101 and D102, are used as forward- and reverse-power detectors. Forward-coupled RF from the power amplifier, and reverse-coupled RF from the antenna are converted to DC voltages FWD and RVS. Detector output is a positive DC voltage, proportional to the amplitude of the RF signal at the input.

### 3.1.3.8 Summing Amplifier U106

This op-amp circuit is a non-inverting buffer. Signals FWD and RVS are summed and sent to the ALC input of the PCIC. When the antenna port is loaded with a low VSWR (voltage standing wave ratio), as in normal operation, RVS is far less than FWD, the amplifier output is a function of FWD, and the radio maintains a constant output power. Under high VSWR conditions, such as when the antenna is damaged or held near a large metal surface, the amplitude of RVS becomes a large fraction of FWD, the amplifier output increases proportionally, and the radio cuts back the transmitter power by up to 50%. This reduces high battery current into a large VSWR transmitter to extend battery life.

### 3.1.3.9 Power-Control IC (PCIC) U104

The PCIC, U104, contains all of the digital, and most of the analog, circuits needed to control the transmitter power amplifier. Host control is through a 3-wire, smart SPI interface. Pin descriptions are shown in [Table 3-3](#).

*Table 3-3. Power Control IC (U104) Pin Descriptions*

Pin	Name	Description
1	RFIN	Detector voltage input to ALC
2	T1	Test point
3	CI	External capacitor for integrator time constant
4	INT	Integrator output; control voltage to amplifiers
5	CJ	External capacitor for PA rise and fall times
6, 7	VL, CL	External capacitor for PA rise and fall times
8	GND1	Ground

Table 3-3. Power Control IC (U104) Pin Descriptions (Continued)

Pin	Name	Description
9	F168	Reference clock input, 2.1 MHz
10, 13	QX, CQX	External capacitor for voltage multiplier
11, 12	Q, CQ	External capacitor for voltage multiplier
14	V10	Voltage multiplier output
15	VG	Internal band-gap reference voltage
16	V45	Regulated 4.5 Vdc output
17	V5EXT	Power supply input for internal voltage regulator
18	VAR2	Buffered D/A output
19	VLIM	Test point for internal D/A No.2 voltage
20	VAR1	Buffered D/A output
21	RS	Asynchronous reset input
22	NA	Spare pin
23	RX	RX/TX mode control-bit output
24	VAR3	Buffered D/A output
25	GND2	Ground
26	CLK	SPI clock input
27	BPOS	Power supply input
28	DATA	SPI data input/output
29	CEX	SPI chip select input
30	TEMP	Temperature sensor input
31	RSET	External resistor; used to set the temperature cutback rate
32	ANO	Switched BPOS output

### 3.1.3.9.1 Power and Control

Since U104 is powered from switched B+, it makes its own regulated 4.5 Vdc to power the internal logic. The supply input is V5EXT at pin 17, and the output is V45 at pin 16. RX at pin 23 is the control signal to the antenna switch control circuit.

### 3.1.3.9.2 Voltage Multiplier

The PCIC contains an internal voltage multiplier. This multiplier produces signal V10 (pin 14), a 10-V supply for the PCIC D/A converters (DACs). This enables the DACs outputs to reach 8 V. The FREF signal is a 2.1 MHz clock used to switch the multiplier. The voltage multiplier is not used in either the VHF, UHF Range 1, UHF Range 2, or 700–800 MHz radio.

### 3.1.3.9.3 Automatic Level Control (ALC)

In TX mode, the PCIC disables the receiver, turns on the transmitter, and controls the TX power level. The automatic level control (ALC) circuit operates as follows:

The power level is set by programming an internal DAC to a calibrated reference voltage. D/A settings for the power set points were determined during radio tuning and stored in EEPROM. An internal op-amp compares the D/A reference voltage to the detector voltage at pin 1(RFIN) (TP101) and produces an error signal output. This signal is buffered by another op-amp, configured as a low-pass filter, or integrator, to produce the INT output at pin 4 (TP104). This signal drives the base of voltage follower Q108.

Transistor Q108 supplies current to drive the gain control pins of amplifiers U102 and Q107. Resistors R105 and R106 determine the voltage ratio between U102 pin 2 (VCNTRL) and the Q107 gate. Transient response during key-up and key-down is controlled by the power amplifier rise and fall times. External capacitors at pins CI, CJ, and CL, along with internal programmable resistors, determine the ALC time constants.

#### 3.1.3.9.4 Temperature Cut Back

The PCIC contains a temperature cut-back circuit to protect the power amplifier (PA) from thermal damage that might result from incorrect assembly of the radio. External sensor U103 is a linear temperature-to-voltage transducer, placed near the hottest spot in the radio: power module Q107. The output is a DC voltage at pin 2 (VOUT) proportional to the temperature at pin 3 (GND). VOUT is 750 mV at 25°C and increases by 10 mV/°C. The PCIC temperature cut-back threshold is programmed to correspond to 85 or 90°C. Above this threshold, the ALC gradually cuts back the transmitter until it is fully turned off at 125°C. The slope of cut-back versus temperature is set by external resistor R111. Diode D104 clamps TEMP to a voltage not much less than VG (pin 15), about 1.3 V, to improve the transient response of the cut-back circuit.

#### 3.1.3.9.5 D/A Outputs

In RX mode, the PCIC shuts down the transmitter, turns on the receiver, and tunes the RX front-end pre-selector filters.

**VHF:** Signal VAR2 supplies the voltage used to tune both front-end preselector filters. The voltage range varies from 1.2 V to 2.4 V across the VHF band.

**UHF Range 1:** Signal VAR2 tunes both receiver preselector filters. Control voltage is in the 1 to 4 V range.

**UHF Range 2:** Signal VAR2 supplies the voltage used to tune both front-end preselector filters. The voltage

range varies from 1.2 V to 3.6 V.

**700–800 MHz:** Signals VAR1 and VAR2 are D/A outputs to the RX front-end preselector filters. Output voltage is in the range of about 1 to 4 V over the frequency band. In TX mode, VAR1 and VAR2 disconnect from the D/A and go to 0 Vdc, thus tuning the RX front-end filters out of band.

### 3.1.4 Frequency Generation Unit (FGU)

The frequency-generation function is performed by several ICs; multiple, discrete, voltage-controlled oscillators (VCOs); and associated circuitry. The reference oscillator provides a frequency standard to the fractional-N frequency synthesizer (FracN) IC, which controls the VCOs and VCO buffer IC (VCOBIC). The VCOBIC amplifies the VCO signal to the correct level for the next stage.

**VHF:** Two VCOs are employed—one to generate the first LO and the other to generate the transmit-injection signals.

**UHF Range 1:** Four VCOs are employed: two transmit and two receive.

**UHF Range 2:** Three VCOs are employed: one transmit and two receive.

**700–800 MHz:** Three VCOs generate the first LO and transmit-injection signals.

**NOTE:** Refer to [Table 8-1, “List of Transceiver Schematics and Board Overlays,”](#) on page 8-1 for a listing of FGU-related schematics that will aid in the following discussion.

### 3.1.4.1 Reference Oscillator Y200

The radio's frequency stability and accuracy derive from the Voltage-Controlled Temperature-Compensated Crystal Oscillator (VCTCXO), Y200. This 16.8 MHz oscillator is controlled by the voltage from the WARP pin of the FracN (fractional-N frequency synthesizer) IC, U202, that can be programmed through a serial peripheral interface (SPI). The oscillator output at pin 3 is coupled through capacitor C234 to the FracN synthesizer reference oscillator input and through C236 (C237 for VHF and UHF Range 2) to the non-invertive input of the op-amp, U201.

Op-amp U201 buffers the 16.8 MHz output to the VOCON board. Components L205 and C214 (C213, L205, and C214 for VHF) form a low-pass filter to reduce harmonics of the 16.8 MHz.

The Digital-to-Analog Converter (DAC) IC, U203, and Switched Capacitors Filter (SCF) IC, FL200, form the interface between radio's DSP and the analog modulation input of the FracN IC.

### 3.1.4.2 Fractional-N Frequency Synthesizer (FracN) IC U202

The FracN IC, U202, is a mixed-mode, Motorola-proprietary, CMOS, fractional-N frequency synthesizer with built-in dual-port modulation. The XTS 5000 radio uses a low-voltage version of the device, sometimes called LVFracN, for compatibility with the 3 V logic used throughout the radio.

The FracN IC incorporates frequency division and comparison circuitry to keep the VCO signals stable. The FracN IC is controlled by the MCU through a serial bus. All of the synthesizer circuitry is enclosed in rigid metal cans on the transceiver board to reduce interference effects.

Separate power supply inputs are used for the various functional blocks on the IC. Inductors L203 and L204 provide isolation between supply pins 20 (AVDD) and 36 (DVDD) connected to Vdd3. Host control is through a three-wire, smart SPI interface (pins 7, 8, and 9) with a bi-directional data pin. FracN functions include frequency synthesis, reference clock generation, modulation control, voltage multiplication and filtering, and auxiliary logic outputs.

#### 3.1.4.2.1 Synthesizer

Frequency synthesis functions include a dual-modulus prescaler, a phase detector, a programmable loop divider and its control logic, a charge pump, and a lock detector output. Fractional-N synthesizer IC principles of operation are covered in detail in the manufacturers' literature. No similar discussion will be attempted here.

#### 3.1.4.2.2 Clocks

U202, pin 23 (XTAL1), is the 16.8 MHz reference oscillator input from the VCTCXO (Y200).

#### 3.1.4.2.3 Modulation

To support many voice, data, and signaling protocols, XTS 5000 radios must modulate the transmitter carrier frequency over a wide audio frequency range, from less than 10 Hz up to more than 6 kHz. The FracN supports audio frequencies down to zero Hz by using dual-port modulation. The audio signal at pin 10 (MODIN) is internally divided into high- and low-frequency components, which modify both the synthesizer dividers and the external VCOs through signal MODOUT (pin 41). The IC is adjusted to achieve flat modulation frequency response during transmitter modulation balance calibration using a built-in modulation attenuator.



#### 3.1.4.2.4 Voltage Multiplier and Superfilter

Pins 12 (VMULT3) and 11 (VMULT4) together with diode arrays D201 and D202 and their associated capacitors form the voltage multiplier. The voltage multiplier generates 11.5 Vdc to supply the phase detector and charge-pump output stage at pin 47 (VCP).

The superfilter is an active filter that provides a low-noise supply for the VCOs and VCOBIC. The input is regulated 5 Vdc from Vdd5 at pin 30 (SFIN). The output is superfiltered voltage FSF at pin 28 (SFOUT).

The output from pin 15 (VMULT1) is used as a clock for the SCF IC, FL200.

#### 3.1.4.3 Loop Filter

The components connected to pins 43 (IOUT) and 45 (IADAPT) form a 3rd-order, RC low-pass filter. Current from the charge-pump output, IOUT, is transformed to voltage VCTRL, which modulates the VCOs. Extra current is supplied by IADAPT for rapid phase-lock acquisition during frequency changes. The lock detector output pin 4 (LOCK) goes to a logic “1” to indicate when the phased-lock loop is *in lock*.

#### 3.1.4.4 VCO Buffer IC (VCOBIC)

The VCOBIC (U302 for VHF radios or U300 for UHF Range 1 and 700–800 MHz radios) is an analog IC containing two NPN transistors for use as oscillators, an active-bias circuit, transmitter and receiver buffer amplifiers, and switching circuitry. The VCOBIC has three RF outputs:

- TX\_OUT (pin 10)—the modulated transmitter carrier
- RX\_OUT (pin 8)—the receiver first LO
- PRESC\_OUT (pin 12)—connected to FracN pin 32 (PREIN) through a matching circuit

Transmit/receive control is a single 5.0 Vdc logic input, TRB\_IN (pin 19). When TRB\_IN is low, the receiver buffer is active and the transmitter circuits are disabled. The converse is also true.

**VHF:** The VCOs in VHF radios use the VCOBIC internal transistors and implement the active bias via resistors R304 and R305. Bias to TX\_OUT is supplied through resistor R313. Components L309 and C316 form a matching circuit for the TX\_OUT impedance. C319 acts as a DC block, and resistors R314, R315, and R316 attenuate an output signal to an optimum level for the PA.

L312 and C320 form a low-pass bias supply filter for the RX\_OUT. L310 and C317 are the RX\_OUT impedance-matching circuit. C322 is a DC block, and resistors R317 and R318 attenuate an output signal to an optimum level for the mixer IC.

An NPN/PNP-packaged transistor, Q301, together with the supporting components R308, R309, and R310, form the 3.3 Vdc-to-5 Vdc logic-level shifter between the AUX3 pin of the FracN IC, U202, and VCOBIC, U302.

**UHF Range 1:** For these radios, four VCOs are used: two transmit and two receive. Control-logic translation is done by level shifter Q310 and Q311, and wired-OR D320.

**UHF Range 2:** Two VCOs are used for receive and one for Transmit. The fractional N synthesizer selects the appropriate VCO by toggling auxiliary lines 2,3, or 4. The selection of the TX VCO with auxiliary line 4 also sets TRB\_IN high.

**700–800 MHz:** These radios use three external, discrete, varactor-tuned, Colpitts VCOs based on transistors Q301, Q303, and Q308. Bias current to the VCOs is switched on and off by the transistors Q302, Q306, and Q309, which are controlled by FracN outputs AUX1, AUX2, and AUX4. Transistor Q304 is an additional transmit buffer amplifier reducing frequency pulling on the transmit VCO. An additional buffer is switched on and off by the transistor Q305. Bias to TX\_OUT is supplied through resistor R307. Components L307 and C208 form a low-pass bias supply filter. The RX\_OUT impedance is matched by a one-component match, coil L310.

Transistors Q307 and Q310 form a 3.3 Vdc-to-5 Vdc logic-level shifter for the signal from the FracN AUX3 pin to the VCOBIC.

## 3.2 VOCON Board

This section provides a detailed circuit description of the ASTRO XTS 5000 VOCON board.

The VOCON board (Figure 3-7) is divided into the following sections:

- Controller and Memory
- Audio and Power
- Interface Support

### 3.2.1 Interconnections

The VOCON board interconnection diagram (see Figure 3-7) contains three functional blocks and five connector symbols.

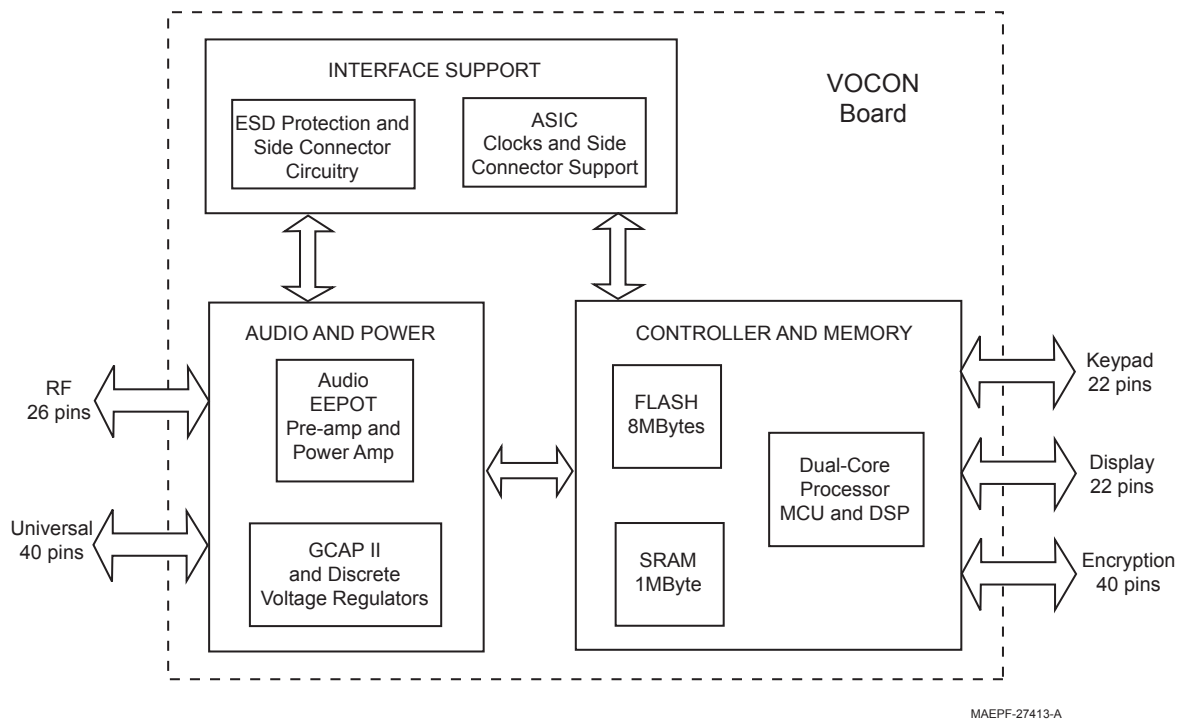

Figure 3-7. VOCON Board Interconnections

The functional blocks consist of the following:

- **Controller and Memory:** The Patriot (U401), the dual-core processor with the microcontroller unit (MCU) and a digital signal processor (DSP), the SRAM (U403) and Flash (U402) memory devices.
- **Audio and Power:** The GCAP II (U501), a 5 Vdc linear regulator (U505), a 1.55 Vdc linear regulator (NNTN4717 VOCON kit only), the audio pre-amplifier (U502), the audio power amplifier (U503), and the dual EEPOT (U509).
- **Interface Support:** The digital-support IC Flipper (U301), ESD protection circuitry, and side connector interface circuitry.

**NOTE:** Refer to [Table 8-2, “List of VOCON Schematics and Board Overlays,”](#) on page 8-1 for a listing of VOCON schematics that will aid in the following discussion.

### 3.2.1.1 Universal Connector J101

This is a 40-pin connector that mates with the universal flex on the housing. A majority of the lines on the connector are for user interface: emergency and side buttons (pin 14), monitor button (pin 17), secure/clear switch (pin 23), frequency switch (pins 24, 25, 26, and 27), volume knob (pin 31), and the three-position switch (pin 34). The LEDs on the universal flex are controlled through pins 20, 21, and 22. Connections to the external accessory connector, which include serial communication data lines, external audio, and option select lines for controlling audio modes, are present at pins 1 through 13. Switched battery voltage (B+SENSE) is provided on pin 32. Most of the pins at this connector have ESD protection devices and components.

### 3.2.1.2 Encryption Connector J701

This 40-pin connector provides the interface between the VOCON board and the encryption module. Two voltages are provided to the encryption board: UNSWB+ and SWB+. The SAP SSI lines, serial communication data lines, and general-purpose I/O lines from the Patriot IC are included in the interface to the encryption board. A number of jumpers are present on some of the lines so that the VOCON board configuration to the encryption board can be changed depending on the encryption type present.

### 3.2.1.3 Keypad Module Connector P107

This 22-pin connector mates the VOCON board to the keypad module flex used on Model II and III radios. The keypad module is provided with 5 volts (pins 7 and 8) for the LEDs. The LEDs are activated by the signal at pin 6, BL\_EN. The row signal lines (pins 13, 14, 15, 16, 17, 18, and 19) and column signal lines (pins 1, 2, and 3) are all at the dual-core processor's GPIO voltage.

### 3.2.1.4 RF Interface Connector P201

This is a 26-pin compression connector that interfaces between the VOCON board and the transceiver board. See Section [3.1.1.2 “VOCON Connector P1,”](#) on page 3-3 for a detailed description of the interface between the VOCON and transceiver boards through P201. Ground clip M202 is used on the bottom side of the VOCON board to contact the transceiver shield. This additional connection provides a consistent, common ground with the VOCON board and the radio chassis.

### 3.2.1.5 Display Module Connector P301

This 22-pin connector mates the VOCON board to the display module flex used on Model II and III radios. The NTN9564 VOCON kit has a parallel data interface to the display module. In this design, two voltages are provided to the display module: 1.8 V and 3 V. The display's parallel data lines (pins 9, 10, 11, 12, 13, 14, 15, and 16), chip select line (pin 5), read/write line (pin 8), register select line (pin 7), and parallel/serial configuration line (pin 4) are at 1.8-V logic levels.

The NNTN4563 and NNTN4819 VOCON kits have a serial data interface to the display module. In this design, only 3 V is provided to the display module on pins 17 and 18. The display's serial data line (pin 16), serial clock line (pin 15), chip select line (pin 5), and register select line (pin 7) are at 3 V logic levels. The NNTN4717 VOCON board has a serial data interface to the display module, and all the lines are at 2.9 V logic levels.

## 3.2.2 Controller and Memory

The controller and memory section contains the following components:

- Patriot IC (U401)

- Static RAM (SRAM) IC (U403)
- Flash memory IC (U402)

The Patriot IC acts as both the microcontroller unit (MCU) and the digital signal processor (DSP) for the radio. The MCU controls receive/transmit frequencies, power levels, display programming, user interface (PTT, keypad, channel select, etc.), and programming of ICs, as well as other functions. The DSP performs voice encoding and decoding, audio filtering, volume control, PL/DPL encode and alert-tone generation, squelch control, and receiver/transmitter filtering, as well as other functions.

The Patriot IC executes a stored program located in the Flash memory device. The SRAM, a volatile device, is used as working memory and shares the address and data bus with the Flash memory device.

**NOTE:** Refer to [Table 8-2, "List of VOCON Schematics and Board Overlays,"](#) on page 8-1 for a listing of VOCON schematics that will aid in the following discussion.

### 3.2.2.1 Patriot IC U401

The Patriot IC U401 is a dual-core processor that contains both a 32-bit microcontroller unit (MCU) and a 16-bit digital signal processor (DSP) in one IC package. It comes in a 256-pin, ball-grid array (BGA) package with 1mm pitch solder balls. On the NTN9564, NNTN4563, and NNTN4819 VOCON boards, the dual-core processor is supplied with two voltages: 1.8 V (E401) and 3 V (E402). The 1.8 V supply is used as the core voltage, as well as the interface voltage, to the memory devices and display (1.8 V display interface only for the NTN9564 VOCON board). Most of the pins on the Patriot IC operate from the 3 V supply.

The NNTN4717 kit uses a new dual-core processor which requires some different operating voltages. The 1.8 V supply is used as the interface to the memory devices, unchanged from the original processor. A 1.55 V supply is used for the core voltage and the clock amplifier module. The remaining pins of the processor use a 2.9 V supply.

**NOTE:** GPIO voltage for the NTN9564, NNTN4563, and NNTN4819 VOCON boards is 3.0 V.

**NOTE:** GPIO voltage for the NNTN4717 VOCON board is 2.9 V.

Two main clocks are provided to the Patriot IC. The CKIH pin (C452) is provided a 16.8 MHz sine wave. This is the most important clock since it is internally used to generate the clocks for both the MCU and DSP cores, as well as most of the peripherals. A 3 V peak-to-peak 32 kHz square wave (32 kHz test point) is generated by the Flipper IC U301 and supplied to the CKIL pin on the Patriot IC. While not as widely used as the 16.8 MHz clock, the 32 kHz clock is needed by some components in the Patriot including the reset circuitry.

#### 3.2.2.1.1 Microcontroller Unit (MCU)

The MCU portion of the Patriot IC has 22.5k x 32 bits of internal RAM and 1k x 32 bits of internal ROM, which is used for the bootstrapping code. The MCU has several peripherals including an External Interface Module (EIM), the Multiple Queue Serial Peripheral Interface (MQSPI), two Universal Asynchronous Receiver/Transmitter (UART) modules, and the One-Wire Interface module. The MCU communicates internally to the DSP through the MCU/DSP Interface (MDI).

##### **External Interface Module (EIM)**

The External Interface Module (EIM) is the MCU interface to the SRAM U403 and Flash Memory U402, as well as the display (only for the NTN9564 VOCON kit). The EIM lines include 24 external address lines, 16 external bi-directional data lines, 6 chip selects lines, read/write line, and output enable line among others. All of the EIM lines operate at 1.8-V logic levels, and the EIM operates at the MCU clock speed.

### **Multiple Queue Serial Peripheral Interface (MQSPI)**

The Multiple Queue Serial Peripheral Interface (MQSPI) is the MCUs programming interface to other ICs. The Patriot IC has two independent SPI busses, and each has its own clock line (test points SCKA and SCKB), data-out line (test points MOSIA and MOSIB), and data-in line (test points MISOA and MISOB). There are 10 SPI chip selects (SPICS) that are programmable to either SPI A, the transceiver board SPI bus, or to SPI B, the dedicated VOCON SPI bus.

The devices on the SPI A bus include the PCIC and FracN IC on the SPICS4 (R131), the Abacus III IC on SPICS5 (R126), an analog-to-digital converter (ADC) on SPICS6 (R133), and the serial EEPROM on SPICS7 (R132). The two SPI B chip selects are for the GCAP II IC U501 on SPICS2 (R539) and the Flipper IC U301 on SPICS3. On the NNTN4563, NNTN4819, and NNTN4717 VOCON boards, two additional SPI chip select lines are used for the display: SPICS0 (R442) and SPICS1 (U407 pin 14). All of the SPI module lines operate at GPIO voltage logic levels.

There are several devices on the transceiver board that only have one bi-directional SPI data line. Components U404, U405, and U406 are configurable by MCU GPIO pin TOUT13 (MISOA\_SEL) to route the data line to the appropriate pin on the Patriot IC depending on which SPI device is being accessed.

### **Universal Asynchronous Receiver/Transmitter (UART)**

The Patriot IC has two Universal Asynchronous Receiver/Transmitter (UART) modules. UART1 handles the RS232 lines while UART 2 is connected to the SB9600 lines. Each UART has a receive data line (URXD), a transmit data line (UTXD), and hardware flow control signals (RTS—request to send) and (CTS—clear to send). All UART lines operate at GPIO voltage logic levels. The translation to 5 V logic levels for the accessory side connector is discussed in the Flipper section.

### **One-Wire Interface**

The MCU has a One-Wire Interface module that is used to communicate to a One-Wire device like a USB cable or a smart battery using the Dallas Semiconductor protocol. This module has one external pin, OWIRE\_DAT (Q504 pin 2), and it uses a GPIO voltage logic level.

#### **3.2.2.1.2 Digital Signal Processor (DSP)**

The DSP portion of the Patriot IC has 84k x 24 bits of program RAM and 62k x 16 bits of data RAM. The DSP has its own set of peripherals including the Baseband Interface Port (BBP), the DSP Timer module, and the Serial Audio CODEC Port (SAP). Additionally, the DSP shares some peripherals with the MCU, including the USB interface and the General Purpose Input/Output module (GPIO).

### **Baseband Interface Port (BBP)**

The Baseband Interface Port (BBP) module is the DSP's serial synchronous interface (SSI) to the transceiver board. The BBP has independent sections for the receiver and the transmitter. The receiver BBP pins include the receive data pin SRDB (R121), the receive clock signal pin SC0B (R124), and the receive frame synchronization (sync) signal pin SC1B (R123). The transmitter's BBP pins include the transmit data pin STDB (R127), the transmit clock signal pin SCKB (R125), and the transmit frame sync signal pin SC2B (R119). All BBP lines use GPIO voltage logic levels.

### **DSP Timer Module**

While the BBP receive clock and frame sync signals are supplied by the Abacus III IC from the transceiver board, the BBP transmit clock and frame sync signals are generated by the DSP Timer. The BBP receive clock, connected to the DSP Timer input pin T10, is reference used to generate the BBP transmit clock and frame sync signals. These two signals, along with the BBP transmit data signal, are connected to the DAC on the transceiver board.

### Serial Audio CODEC Port (SAP)

The Serial Audio CODEC Port (SAP) module is the DSP's serial synchronous interface (SSI) to the audio CODEC on the GCAP II IC. The SAP also interfaces with the encryption module.

The SAP interface consists of four signals including the SAP clock line pin SCKA (component R405), the SAP frame sync line pin SC2A (component R406), the SAP receive data line pin SRDA (component R402), and the transmit data line pin STDA (component R403). On the NTN9564, NNTN4563, and NNTN4819 VOCON boards, the SAP clock is generated by the Flipper IC U301, and is a 520 kHz, 3 V peak-to-peak square wave. The SAP frame sync signal is also generated by the Flipper IC, and is an 8 kHz, 3 V peak-to-peak square wave.

On the NNTN4717 VOCON board, the SAP clock is generated by the dual-core processor U401, and is a 256 kHz, 2.9 V peak-to-peak square wave. The SAP frame sync signal is generated by the dual-core processor U401, and is an 8 kHz, 2.9 V peak-to-peak square wave.

### Universal Serial Bus (USB)

The Patriot IC USB peripheral, shared by the MCU and the DSP, provides the required buffering and protocol to communicate on the Universal Serial Bus. The Patriot IC supports USB slave functionality.

For receive data, the USB differentially decoded data comes from the Flipper IC URXD\_RTS pin into the Patriot URTS1 pin, while the single-ended USB data positive signal goes to pin PA2\_USB\_VPIN, and the single-ended USB data minus signal goes to pin URXD1. The two data lines are used to detect the single-ended zero state.

For transmit data, the USB data comes out of the Patriot IC UTXD1 pin and goes to the Flipper IC TXD\_USB\_VPO pin. The USB transmit single-ended zero signal is generated from the Patriot IC PC0\_USB\_VMOOUT pin.

### General-Purpose Input/Output (GPIO) Module

The General-Purpose Input/Output (GPIO) module is shared by the MCU and the DSP. This module consists of four 16-pin bi-directional ports and a 15 pin bi-directional port. While some of the pins on these ports are being used for other functions (UART, SPI, SAP, BBP, and Interrupt pins), the remaining pins can be programmed to become GPIOs that can be used by either the DSP or the MCU. Each GPIO pin has up to 8 alternate output functions and up to 4 alternate input functions. This allows for the GPIO pins to be routed internally to pertinent Patriot IC modules. Additionally, the GPIO module adds selectable edge-triggered or level-sensitive interrupt functionality to the GPIO pins. Some examples of GPIO pins include the Audio PA control signals (EXT\_SPKR\_SEL, AUDIO\_PA\_EN, and AUDIO\_MODE\_SEL), the EEPROM control signals (EEPOT\_INC\*, EEPOT\_U\_D\*, EEPOT\_CS\*, and EEPOT\_CS\_EXT\*), and the LED control signals (RED\_LED and GREEN\_LED).

#### 3.2.2.2 Static RAM (SRAM) U403

The static RAM (SRAM) IC U403 is an asynchronous, 1 MB, CMOS device that is capable of 70 ns access speed. It is supplied with 1.8 volts. The SRAM has its 19 address lines and 16 data lines connected to the EIM of the Patriot IC through the Address(23:0) and Data(15:0) busses.

The SRAM has an active-high chip select CS2 that is tied directly to the 1.8 V supply and an active-low chip select CS1 that is connected to the EIM CS2\_N pin (test point CS2). When the SRAM CS1 pin is not asserted, the SRAM is in standby mode, which reduces current consumption.

Two other control signals from the EIM that change the mode of the SRAM are the read/write signal, R/W, and the output enable signal, OE. The R/W of the EIM is connected to the SRAM EN\_WE pin (test point R\_W), while the OE signal from the EIM is connected to the SRAM EN\_OE pin. The SRAM is in read mode when the EN\_WE pin is not asserted and the EN\_OE pin is asserted. The SRAM is in write mode when the EN\_WE pin is asserted, regardless of the state of the EN\_OE pin.

The other SRAM pins are the lower-byte enable pin LB and the upper-byte enable pin UB. These pins are used to determine which byte (LB controls data lines 0-7 and UB controls data lines 8-15) is being used when there is a read or a write request from the Patriot IC. The LB pin is controlled by the EIM EB1\_N signal, while the UB pin is controlled by the EB0\_N signal.

### 3.2.2.3 FLASH Memory U402

The Flash memory IC is an 8 MB CMOS device with simultaneous read/write or simultaneous read/erase operation capabilities with 70 ns access speed. It is supplied with 1.8 volts. The Flash memory has its 22 address lines and 16 data lines connected to the EIM of the Patriot IC through the Address(23:0) and Data(15:0) busses. The Flash memory contains host firmware, DSP firmware, and codeplug data with the exception of the tuning values that reside on the transceiver board's serial EEPROM. The Flash memory IC is not field repairable.

The RESET\_OUT of the Patriot IC is at a GPIO voltage logic level. Components D401 and R401 are used to convert the voltage down to a 1.8 V logic level, and this 1.8 V reset signal is fed to the Flash RESET pin. When this pin is asserted (active low logic), the Flash is in reset mode. In this mode, the internal circuitry powers down, and the outputs become high-impedance connections.

The Flash active-low chip select pin, EN\_CE, is connected to the active-low CS0\_N pin (CS0 test point) of the EIM. When the EN\_CE is not asserted, the Flash is in standby mode, which reduces current consumption.

Several other active-low control pins determine what mode the Flash memory is in: the address valid pin ADV (ADV test point) that is connected to the EIM LBA\_N signal, the output enable pin EN\_OE that is connected to the EIM OE\_N signal, and the write enable pin EN\_WE that is connected to the EIM EB1\_N signal. For read mode, the ADV and EN\_OE pins are asserted while the EN\_WE pin is not asserted. When the EN\_WE is asserted and the EN\_OE pin is unasserted, the Flash operates in the write mode.

Figure 3-8 illustrates the EIM and memory ICs block diagram.

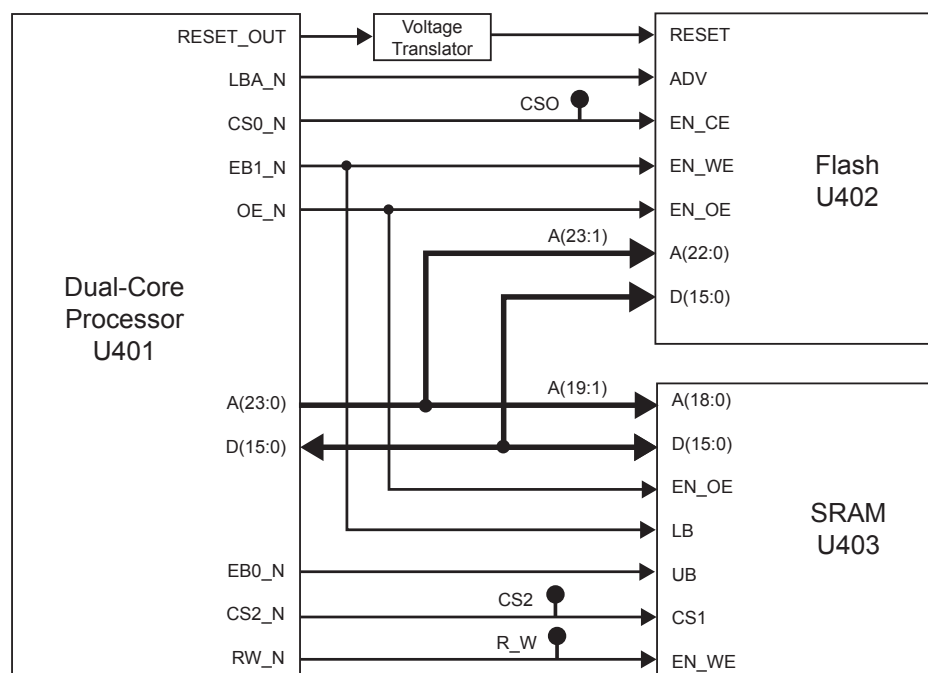

MAEPF-27414-A

Figure 3-8. Patriot EIM and Memory Block Diagram



### 3.2.3 Audio and Power

The audio and power section contains the following components:

- GCAP II IC U501
- 5 V regulator U505
- Audio pre-amplifier U502
- Audio power amplifier U503
- EEPOT U509
- 1.55 V regulator (NNTN4717 VOCON board only)

The GCAP II IC contains a CODEC, amplification, filtering, and multiplexing capability for receive and transmit audio, voltage regulators, an analog-to-digital converter (ADC), and a real-time clock (RTC). The GCAP II IC is programmed by the Patriot IC.

The audio pre-amplifier and the audio power amplifier condition the received audio signal before being routed to the speaker. The dual EEPOT sets the gain of the microphone signal. These devices are programmed by the Patriot IC.

**NOTE:** Refer to [Table 8-2, “List of VOCON Schematics and Board Overlays,”](#) on page 8-1 for a listing of audio and power-related schematics that will aid in the following discussion.

#### 3.2.3.1 GCAP II IC U501

The GCAP II IC is a mixed-signal (analog and digital) IC that provides control, audio, and voltage regulation functionality. It comes in a 100-pin, ball-grid array (BGA) package with 0.8 mm pitch solder balls. The GCAP II IC is supplied with switched battery voltage GCAP\_B+ (R581).

##### 3.2.3.1.1 Voltage Regulation

The GCAP II IC contains several voltage regulators that are used in the design of the VOCON board: VSW1, VSW2, and V2. The VSW1 regulator is a programmable switching regulator that uses the switched battery voltage as its input on pin PSRC1. The output voltage of VSW1 (R502) is programmable by the Patriot IC U401 through the SPI bus. The initial output of VSW1 is 3.2 volts, which is then programmed to 3.8 volts. The VSW1 voltage is supplied to the RF Interface connector P201 pin 15 and to the input pins of the VSW2 and V2 regulators.

The VSW2 regulator is a SPI programmable switching regulator that uses VSW1 as its input on pin PSRC2. The initial output of VSW2 (R501) is 2.2 volts, which is then programmed to 1.875 volts (referred to as 1.8 volts throughout this document). The VSW2 voltage is supplied to the Patriot IC (core voltage and the EIM voltage), the SRAM U403, the Flash memory U402, and the display module connector J301 (1.8 V display interface only for the NTN9564 VOCON kit).

The V2 regulator is a SPI programmable linear regulator that uses VSW1 as its input on pin VIN2. The initial output of V2 (R560) is 2.775 volts, which is then programmed to 3 volts for the NTN9564, NNTN4563, and NNTN4819 VOCON boards, and 2.9 volts for the NNTN4717 VOCON board. The V2 voltage is supplied to the Patriot IC (I/O ring - SPI, BBP, SAP, UART, GPIO, etc.), the Flipper IC U301, the EEPOT U509, the display module connector J301, and the many discrete components that interface with the Patriot IC and the Flipper IC.



### 3.2.3.1.2 MCU Interface

The GCAP II IC has a four-wire, SPI connection to the Patriot IC (SPI B). The SPI B clock is connected to the SPI\_CLK pin (test point SCKB). The SPI B MOSI line is connected to the SPI\_DW pin (test point MOSIB). The SPI B MISO line is connected to the SPI\_DR pin (test point MISOB). The GCAP SPI B chip-select signal is connected to the CE pin (R539). Through this interface, the Patriot IC can program the voltage regulators, the CODEC, the transmit and receive audio filters and amplifiers, as well as read information from the ADC and the real-time clock.

The GCAP II IC has an 8-bit ADC with general-purpose six channels and four voltage-monitoring channels. The six general-purpose analog-to-digital (A/D) channels are assigned to monitor volume (AD5); the three-position toggle switch from the universal connector J101 (AD1); the emergency, monitor, and side buttons (AD0); the battery status line (AD2); the board type indicator (AD3); and the board identification voltage (AD4). Battery voltage is also monitored by the ADC. The Patriot IC activates and reads the A/D values through the SPI bus.

The real-time clock (RTC) module of the GCAP II IC consists of several counters to determine elapsed time. The Patriot IC reads the RTC registers through the SPI bus. The RTC is supplied with voltage from a backup lithium rechargeable battery (LI\_CELL) and a 32.768 kHz clock signal from the Flipper IC to the GCAP II IC XTAL1 pin.

### 3.2.3.1.3 Audio Circuitry

A 13-bit CODEC, internal to the GCAP II IC and programmable by the Patriot IC through the SPI bus, converts microphone audio into a digital bit stream for processing by the DSP. The CODEC also converts receive audio data that was processed by the DSP into an analog audio signal for amplification to a speaker. The CODEC interfaces to the DSP through the 4-wire SAP bus. The CODEC clock, which is 520 kHz (for the NTN9564, NNTN4563, and NNTN4819 VOCON boards) or 256 kHz (for the NNTN4717 VOCON board) is supplied to the DCLK pin. The CODEC 8 kHz CODEC frame synchronization signal is supplied to the FSYNC pin. The CODEC transmit data signal is on the TX pin, while the CODEC receive data signal is on the RX pin. For the CODEC to operate with those clock and frame sync signals, a 13 MHz clock (R302), generated by the Flipper IC, is supplied to the GCAP CLK\_IN pin.

The GCAP II IC contains internal amplification, filtering, and multiplexing functionality for both receive and transmit audio. These functions are Patriot IC-programmable through the SPI bus. The input for the internal microphone audio (R540) is the MICIN\_NEG pin, while the input for the external microphone audio (R566) is the AUX\_MIC\_NEG pin. The output for the speaker audio is the EXTOUT pin (C533).

### 3.2.3.2 5 V Regulator U505

The 5 V regulator uses UNSW\_B+ as its input voltage. The Flipper IC WDI line controls the regulator's SHUTDOWN pin. The 5 V supply (R503) is used by the Flipper IC U301, audio pre-amplifier U502, microphone bias circuitry (R531 and R563), Flipper IC protection diodes, bi-directional voltage translators, battery data-line isolation circuitry, and ESD protection circuitry.

### 3.2.3.3 1.55 V Regulator

The 1.55 V regulator is made up of the following components: U508, Q503, R598, R507, R508, R509, R512, R599, C576, C565, C512, C580, and C567 (check the NNTN4717 VOCON board BOM for part values and placement). This circuit uses VSW1 to bias the regulator while VSW2 sources the current. This voltage is used by the dual-core processor U401 for its core voltage and clock amplifier. The 1.55 V regulator is only instantiated on the NNTN4717 VOCON board.

### 3.2.3.4 Audio Pre-Amplifier U502

The audio pre-amplifier U502 is a single-package, 5-pin, op-amp supplied with 5 volts. This pre-amp stage provides a fixed gain, which is selected by the components R551 and R537. The input (U502 pin 4) of stage is the EXTOUT pin from the GCAP II IC, while the output (U502 pin 1) of this stage goes to the audio PA.

### 3.2.3.5 Audio Power Amplifier U503

The audio power amplifier (PA) U503 consists of two BTL amplifiers, complementary outputs, and control logic. Each of the amplifiers has a fixed gain—the external audio PA gain is set by components R553 and R554, while the internal audio PA gain is set by components R549 and R550. The MODE pin (U503 pin 4) voltage determines the operation of the amplifier. That voltage is controlled by the Patriot IC GPIO lines AUDIO\_PA\_EN (to Q505) and AUDIO\_MODE\_SEL (to Q506). [Table 3-4](#) describes how the Patriot IC GPIO lines configure the audio PA.

Table 3-4. Audio PA Status

AUDIO_PA_EN	AUDIO_MODE_SEL	Audio PA Status	MODE Voltage
0	0	Standby	$V_{\text{Mode}} > 7 \text{ V}$
0	1	Mute	$1.5 \text{ V} < V_{\text{Mode}} < 6 \text{ V}$
1	0	On	$V_{\text{Mode}} < 0.5 \text{ V}$
1	1	On	$V_{\text{Mode}} < 0.5 \text{ V}$

The SELECT pin (U503 pin 6) is used to switch the audio path between internal and external speaker. The voltage on that pin is determined by the EXT\_SPKR\_SEL line from the Patriot IC and the Q505 transistor. When the voltage at the SELECT pin is high (B+), the audio is routed to the internal speaker lines. When the voltage at the SELECT pin is low ( $V_{\text{select}} < 0.5\text{V}$ ), the audio is routed to the external speaker lines.

### 3.2.3.6 EEPOT U509

The EEPOT is a digitally programmable potentiometer with 256 taps and a total resistance of 50 kohms. This 10-pin package contains two independent potentiometers, one for each microphone line. The EEPOT resistance values are programmed by the Patriot IC GPIOs EEPOT\_INC\* (U509 pin 9) and EEPOT\_U\_D\* (U509 pin 2). The EEPOT\_INC\* signal increments the resistance value up or down, which depends on the EEPOT\_U\_D\* signal. The EEPOT\_CS\* line (U509 pin 10) is asserted when the internal microphone gain is being changed. Similarly, the EEPOT\_CS\_XST\* (U509 pin 1) is asserted for external microphone gain changes. The EEPOT is supplied with voltage from the GCAP II V2 regulator.

## 3.2.4 Interface Support

The interface support section consists of the following:

- Flipper IC U301
- ESD protection circuitry
- Universal connector interface circuitry

The Flipper IC contains a USB transceiver, switching logic between RS232 and boot data path, One-Wire side connector support, and several clock generators. The Flipper IC is programmed by the Patriot IC.

ESD protection devices include zener diodes and low-capacitance ESD suppressors.

Side connector interface circuitry includes current-limiting resistors and noise-suppressing shunt capacitors.

### 3.2.4.1 Flipper IC U301

See [Figure 8-64, "NTN9564B VOCON Flipper Circuit," on page 8-99](#) for schematic details of the following discussion.

The Flipper IC U301 is an application-specific, integrated circuit (ASIC) device designed for the XTS-radio product line. The Flipper IC is contained in a 64-pin  $\mu$ BGA package with 0.8 mm pitch solder balls. The Flipper IC is supplied with 5 volts and the processor's GPIO voltage, and it uses the 16.8 MHz clock (C307) as its master clock. The Flipper IC is programmable by the Patriot IC through the SPI bus.

The Flipper IC supports many functions including the radio side connector interface, bi-directional logic level translation, boot data path control, USB transceiver, One-Wire option detect support, watchdog timer, 32 kHz oscillator with CMOS output, 13 MHz reference generation for the GCAP II IC, and SSI clock and frame sync generator.

#### 3.2.4.1.1 Side Connector Interface, Logic Level Translation, and Boot Data Path Control

The Flipper IC facilitates the interface to the radio's side connector. Some of the side connector lines are at 5 V logic levels, so the Flipper IC converts those lines to GPIO voltage logic levels to interface to the Patriot IC, as well as the encryption module. These lines include the SB9600 bus busy line LH\_BUSY (TP207), the RS 232 CTS (TP208) and RTS (TP209) lines, the RS232 data-out line (TP210), and the RS232 data-in line (TP211). The SB9600 data line uses an external, bi-directional, voltage translation circuit that includes Q303, D301, R325, R326, and R327.

Another function that the Flipper IC provides with these lines is boot data path control. The boot data path is as follows: boot data-in is multiplexed onto the RS232 data-out line while the boot data-out is multiplexed with the SB9600 data line. This alternate data path is used only to Flash code into a radio for the first time. The Patriot IC, through the SPI bus, controls this feature.

#### 3.2.4.1.2 USB Transceiver

The USB transceiver, internal to the Flipper IC, is capable of transmitting and receiving serial data at a rate of 12 megabits per second. The differential USB data comes from the side connector, through the 22-ohm resistors R252 and R253 and the isolation switch Q301, and then to the USB\_DPLUS and USB\_DMINUS pins on the Flipper IC. The USB receive interface from the Flipper IC to the Patriot IC is as follows: USB\_DPLUS routed to USB\_VPI, USB\_DMINUS routed to USB\_VMI\_RXD, and the differential decoded data is output at the URXD\_RTS pin and goes to the Patriot IC URTS1 pin.

The USB transmitter is enabled when the USB\_SUSP and USB\_TXENAB signals are both driven low by the Patriot IC. The single-ended data is output from the Patriot IC on the UTXD1 pin and goes to the Flipper TXD\_USB\_VPO pin. The data is driven out differentially on the USB\_DPLUS and USB\_DMINUS pins, which go to the side connector. The Patriot IC sends the single-ended zero signal from pin PC0\_USB\_VMOOUT to the Flipper IC USB\_FSEZ pin.

When a USB cable is detected, the USB\_DIS pin (Q302 pin 2) goes high. This controls the isolation switch Q301 so that the data that is on those lines are routed to the USB transceiver. If a USB cable is not detected, the USB\_DIS pin is low and the USB transceiver on the Flipper IC is isolated from the side connector. This isolation is done primarily because the RS232 data lines are 5 V lines, so the switch protects the transceiver since it operates at a lower voltage, and the USB data lines to the side connector also act as the RS232 lines.

On the NNTN4717 VOCON board, the USB transceiver on the Flipper IC is not used. Instead, a discrete USB transceiver U310 is used. This transceiver is provided with 5 V and 2.9 V. The 5 V powers an internal 3.3 V voltage regulator on the transceiver, which is used as the voltage for the USB data pins D+ and D- as well as the VPU pin. The 2.9 V is used by the remaining pins as they interface to the dual-core processor U401.

#### 3.2.4.1.3 One-Wire Support

New options and accessories that attach to the side connector are identified by the Patriot IC using the One-Wire protocol. The Option Select 2 pin on the side connector also serves as the One-Wire data pin (R218). This signal is connected to the ONE\_WIRE\_OPT pin. This pin is connected to the Patriot IC One-Wire bus ONE\_WIRE\_UP through an internal isolation switch controlled by a Patriot IC GPIO line to the Flipper IC ONE\_WIRE\_EN\_X pin. This isolation is needed to prevent possible contention on the One-Wire bus when a smart battery is attached to the radio.

These new accessories are to ground pin 10, CTS (TP208), of the side connector. When this occurs, the Flipper IC pin KVL\_USB\_DET\_X is asserted and the Patriot IC detects the change. The Patriot IC then asserts the ONE\_WIRE\_EN\_X pin on the Flipper IC to connect the side connector One-Wire line to the Patriot IC One-Wire bus. In the case of the USB cable, the Patriot IC reads the One-Wire data from the cable and, upon determining that a USB cable is attached, programs the Flipper IC for USB mode.

#### 3.2.4.1.4 Watchdog Timer

The Flipper IC monitors the position of the radio's On/Off switch on the BP\_SEN\_X pin, and that signal is located on Q508 pin 3. If the voltage on pin 3 is ground, then the radio is turned on. If the voltage on pin 3 is 3 volts, then the radio is off. When the radio is turned off, a counter inside the Flipper IC begins incrementing. That counter can be refreshed by the Patriot IC through the SPI bus. This is done so that the software has enough time to complete its tasks before the power is taken away from the Patriot IC. If the counter is not refreshed by the time the count is complete, the Flipper IC pin WD\_OUT goes low, which shuts down the GCAP II voltage regulators. During normal radio operation, WD\_OUT should be high (V2 regulated voltage).

#### 3.2.4.1.5 32 kHz Oscillator and CMOS output

The 32 kHz oscillator circuitry uses a separate voltage supply pin (VDD3\_XTL) than the other 3-V portions of the Flipper IC. This 32 kHz clock is used by the GCAP II RTC module to keep track of time. The VDD3\_XTS pin is supplied with the backup lithium (Li) rechargeable battery voltage LI\_CELL. The oscillator circuitry is internal to the Flipper IC, and the 32.768 kHz crystal Y301 and additional load capacitors C308 and C309 are located next to the IC.

The output of the 32 kHz oscillator is an LI\_CELL voltage (approximately 3 volts peak-to-peak), 32.768 kHz square wave on pin REF32\_OUT. This clock goes to two destinations: the Patriot IC CKIL pin (32 kHz test point) as a square wave and the GCAP II IC XTAL1 pin (C306) as a sine wave. Components C306 and C313 are used to filter the square wave into a sine wave before the signal goes to the GCAP II IC.

#### 3.2.4.1.6 13 MHz Reference Generation for GCAP II

The 13 MHz reference is required by the GCAP II IC for the CODEC time base and the SSI clock generator module internal to the Flipper IC. A phase locked loop (PLL) is used to generate the 13 MHz using the 16.8 MHz clock, which is provided to the Flipper IC REF\_16\_IN pin (C307). An external RC loop filter network, consisting of R301, C301, and C302, is connected to the PLL\_LFT pin.

The 13 MHz reference output pin, REF\_13\_OUT, is conditioned by the RC network of R302 and C303. The signal at REF\_13\_OUT is a 3-V peak-to-peak square wave, and the RC filter produces a lower-level triangle wave that is suitable for the GCAP II IC.

The 13 MHz reference is disabled as the Flipper IC powers up. The 13 MHz reference is enabled by the Patriot IC through the SPI bus, and, during normal radio operation, this signal should be present.

#### 3.2.4.1.7 SSI Clock and Frame Sync Generator

The Flipper IC generates the SSI clock and frame sync signals for the SAP bus used by the Patriot IC, GCAP II IC, and encryption module. These signals are generated from the 13 MHz reference. The SSI clock output pin is labeled SSI\_CLK, and the frequency is 520 kHz. The SSI frame sync output pin is FRSYNC, and the frequency is 8 kHz. These signals are not active when the Flipper IC comes out of reset, so they are programmed by the Patriot IC through the SPI bus.

The Flipper IC provides four 16-bit TDM slots per frame on the SAP bus. The first slot (slot 0) begins immediately after the frame sync pulse, and this slot is used by the GCAP II IC. The SEC\_SS\_X pin is active for the first 8 bits of the second slot (slot 1). This signal is used by the encryption module to synchronize its input and output to the SSI frame. The other two slots are reserved for possible design additions in the future.

On the NNTN4717 VOCON board, the Flipper IC is not programmed to generate the SSI clock, SSI frame sync signal, or the secure slave select signal (SEC\_SS\_X); the dual-core processor U401 generates these signals.

#### 3.2.4.2 ESD Protection Circuitry

See [Figure 8-63, "NTN9564B VOCON Universal Connector Circuit," on page 8-98](#) for schematic details of the following discussion.

Several components on the VOCON board protect the circuitry from ESD. The side connector signal lines have ESD protection components on them since they are exposed. These protection components include:

- 5.6-V zeners VR205, VR206, VR220, and VR221 on the SB9600 lines, RS232 lines, microphone lines, and option-select lines
- 12-V zeners VR201, VR203, and VR209 on the internal and external speaker audio lines
- 13-V zener VR204 on the OPTB+ line
- Low-capacitance ESD suppressors D203, D204, D205, and D206 on audio lines, USB data lines, and option-select lines

There were also several protection diodes on lines connected to the Flipper IC. These include D302, D303, D304, D305, D306, D307, and D308. ESD protection for the battery status line is provided by a 5.6-V zener VR501.

### 3.2.4.3 Universal Connector Interface Circuitry

See Figure 8-63, “NTN9564B VOCON Universal Connector Circuit,” on page 8-98 for schematic details of the following discussion.

Some important components on the universal connector interface are two op-amps. The first op-amp, U201, is used as a comparator for the option-select 1 line. The comparator threshold is determined by the voltage-divider network of R257 and R258. Similarly, the other op-amp, U202, is used as a comparator for the option-select 2 line. The comparator threshold is determined by the voltage-divider network of R240 and R243. The remaining components consist of current-limiting serial resistors and noise-suppressing shunt capacitors.

#### 3.2.4.3.1 Universal Connector and Option Selects

The universal connector is located on the side of the radio. It is the external port or interface to the outside and is used for programming and interfacing to external accessories. The universal connector connects to the VOCON board at connector J101 via a flex circuit that is routed inside the external housing. Connections to the universal connector and J101 on the VOCON board are shown in Figure 3-9 on page 3-28 and Figure 3-10 on page 3-28.

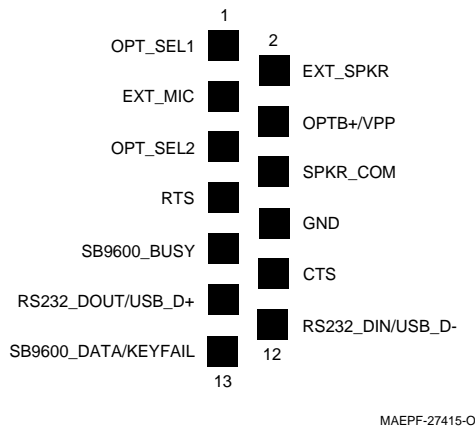

Figure 3-9. Universal (Side) Connector

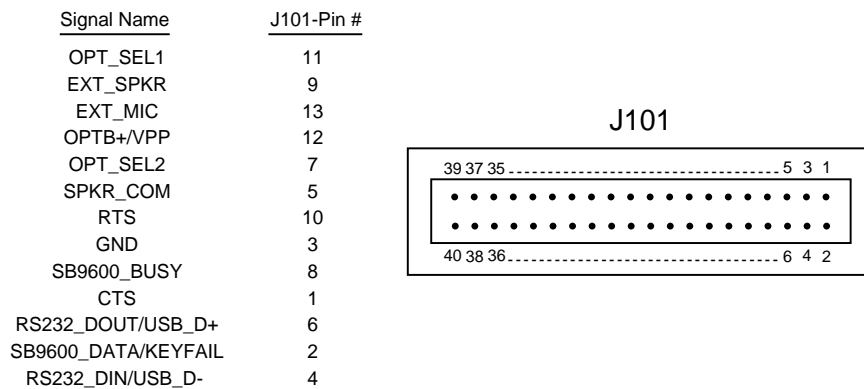

Figure 3-10. VOCON Board Connector—J101



Most of the signals are extensions of circuits described in other areas of this manual. However, there are two option select pins (see [Table 3-5](#)) used to configure special modes: Option Select 1 and Option Select 2. These pins are controlled by accessories connected to the universal connector. [Table 3-5](#) outlines their functions as defined at the universal connector. In the case of the XTS Vehicular Adapter (XTVA), Option Select 1 pin is connected to Option Select 2 pin by a diode internal to the XTVA.

*Table 3-5. Option-Select Functions*

Function	Option Select 1	Option Select 2
External PTT	0	0
No Function (Normal)	1	1
Man Down	1	0
External Speaker	0	1
XTVA	Diode cathode	Diode anode

### 3.2.4.4 Display Module

An optional, integral, 96 pixels by 64 pixels, bit-mapped, liquid-crystal display (LCD) module is available with either a 3 x 2 keypad with a navigational button (Model II radios) or 3 x 6 keypad with a navigational button (Model III radios). The display module is connected to the VOCON board through flex connector J301. The display module uses chip-on-film technology and is not field repairable.

#### 3.2.4.4.1 7285726C01 Display Module

**NOTE:** The NTN9564 VOCON kit is only compatible with the 7285726C01 display module.

The 7285726C01 display module is controlled by the Patriot IC MCU core, which programs the display through the EIM data lines D0 - D7 (pins 9 through 16, respectively), the display chip select line (pin 5), the EIM read/write line (pin 8), and the EIM address 0 line (pin 7) that is used to select the register to be programmed. The Patriot IC can reset the display module through pin 6. The display is supplied with 1.8 V (B102) to pin 17 and 3.0 V (B101) to pin 18. Display backlighting is controlled by the Patriot IC GPIO line BL\_EN signal through components R140 and Q101. The LEDs on the display module are powered by 5 V going through resistors R101, R102, R103, and R104.

#### 3.2.4.4.2 7285726C02 and 7285726C03 Display Modules

**NOTE:** The NNTN4563 VOCON kit is compatible only with the 7285726C02 display module, while the NNTN4819 VOCON kit is compatible only with the 7285726C03 display module. Check the model charts for display part number compatibility with the NNTN4717 VOCON board.

The 7285726C02 and 7285726C03 display modules are controlled by the Patriot IC SPI bus, which programs the display through the serial data line (pin 16), the serial clock line (pin 15), chip select line (pin 5), and register select line (pin 7) that is used to select the register to be programmed. The Patriot IC can reset the display module through pin 6. The display is supplied with GCAP II V2 regulated voltage (B101) to pins 17 and 18. Display backlighting is controlled by the Patriot IC GPIO line BL\_EN signal through components R140 and Q101. The LEDs on the display module are powered by 5 V going through resistors R103 and R104.

### 3.2.4.5 Keypad Module

The keypad module is either a 6- x 3-button (Model III) or a 2- x 3-button (Model II) module with backlighting.

The keypad module is connected to the VOCON board through flex connector J107. The keypad is read through a row-and-column matrix made up of ROW1, ROW2, ROW3, ROW4, ROW5, ROW6, and COL1, COL2, and COL3. When a key is pressed, a row and a column are connected to each other. The Patriot IC determines a key press by a scanning algorithm. Each column line is configured as an open drain output and pulled low. The Patriot IC then scans the row pins (each row pin has an internal pull-up resistor). If a row signal is read low, then the Patriot IC determines that a key was pressed. If none of the row signal lines are low, then another column line is pulled low and the row scanning routine occurs.

The keypad backlighting is controlled by the Patriot IC GPIO BL\_EN, and that signal goes to pin 6 of the J107 connector. Pins 7 and 8 are supplied with 5 volts, which is used to power the LEDs on the keypad module.

### 3.2.4.6 Controls and Control Top Flex

The universal flex assembly contains an On/Off switch/volume control knob, frequency selector switch, push-to-talk (PTT) switch, monitor button, several function-selectable switches, universal connector, speaker, and microphone.

The housing assembly top controls include the On/Off switch/volume control (S1), a 16-position mode-select switch with programmable two-position concentric switch (U1), a programmable three-position (A,B,C) toggle switch (S2), and a programmable top (orange) button (SW3). The side controls include three programmable, momentary, pushbutton switches (side button 1 [SB2], side button 2 [SB3], top side button [SB1]) and a PTT switch (SW2). These components are connected through a flex circuit to the controller at J101 (see [Table 3-11, "Control Top Flex," on page 3-31](#)). The assembly also contains the radio's internal speaker and internal microphone.

UNSW\_B+ is routed through switch S1 to provide the B+SENSE signal, which is used to activate the SW\_B+ and GCAP\_B+ voltages that, in turn, power up the radio. Volume control is also provided by S1, which contains a potentiometer biased between V2 regulated voltage and ground. The VOL signal is a voltage level between V2 regulated voltage and ground, depending on the position of the rotary knob. The VOL signal is fed to buffer U507 pin 3, and then the output of the buffer is voltage-divided down to 2.5 volts before the signal goes to the GCAP II IC AD5 pin. The Patriot IC reads the GCAP II IC A/D value through the SPI bus, and from this reading, the Patriot IC DSP adjusts the speaker volume.

Switch S2 is the three-position, programmable, toggle switch typically used for expanded zone/channel selection. The switch can output the following voltages: 0 volts, half of the V2 regulated voltage, or V2 regulated voltage (measurable at R231). The switch is connected to the GCAP II IC AD1 input pin through the voltage divider network of R519 and R523. The Patriot IC reads the A/D value through the SPI bus, and it uses that reading to determine the position of the toggle switch.

The programmable top (orange) button SW3 is typically used for emergency. This button, along with programmable side buttons SB1 through SB3, is connected to a resistor divider network, biased between V2 regulated voltage and ground. This network, made up of R1, R2, and R3, provides a voltage level, controlled by whichever button is pressed, to pin 3 of buffer U504. The output of the buffer is voltage- divided down to 2.5 volts before the signal goes to the GCAP II IC AD0 pin. The Patriot IC reads the GCAP II IC A/D value through the SPI bus, and it uses that data to determine which button was pressed.

LED D1 is the TX/RX indicator. LEDs D2 through D6 are used for backlighting the frequency knob.



U1 is a binary-coded switch. The output pins from U1, which are connected to GPIO pins on the Patriot IC, provide a four-bit binary word (signals RTA0, RTA1, RTA2, and RTA3) to the MCU, indicating to which of the 16 positions the rotary is set. This switch provides an additional output, TG2, which is typically used for coded or clear mode selection. It is an input to the Patriot IC TOUT8\_PD4 GPIO pin. Selecting clear mode pulls this signal to a logic low, and it can be monitored from R234.

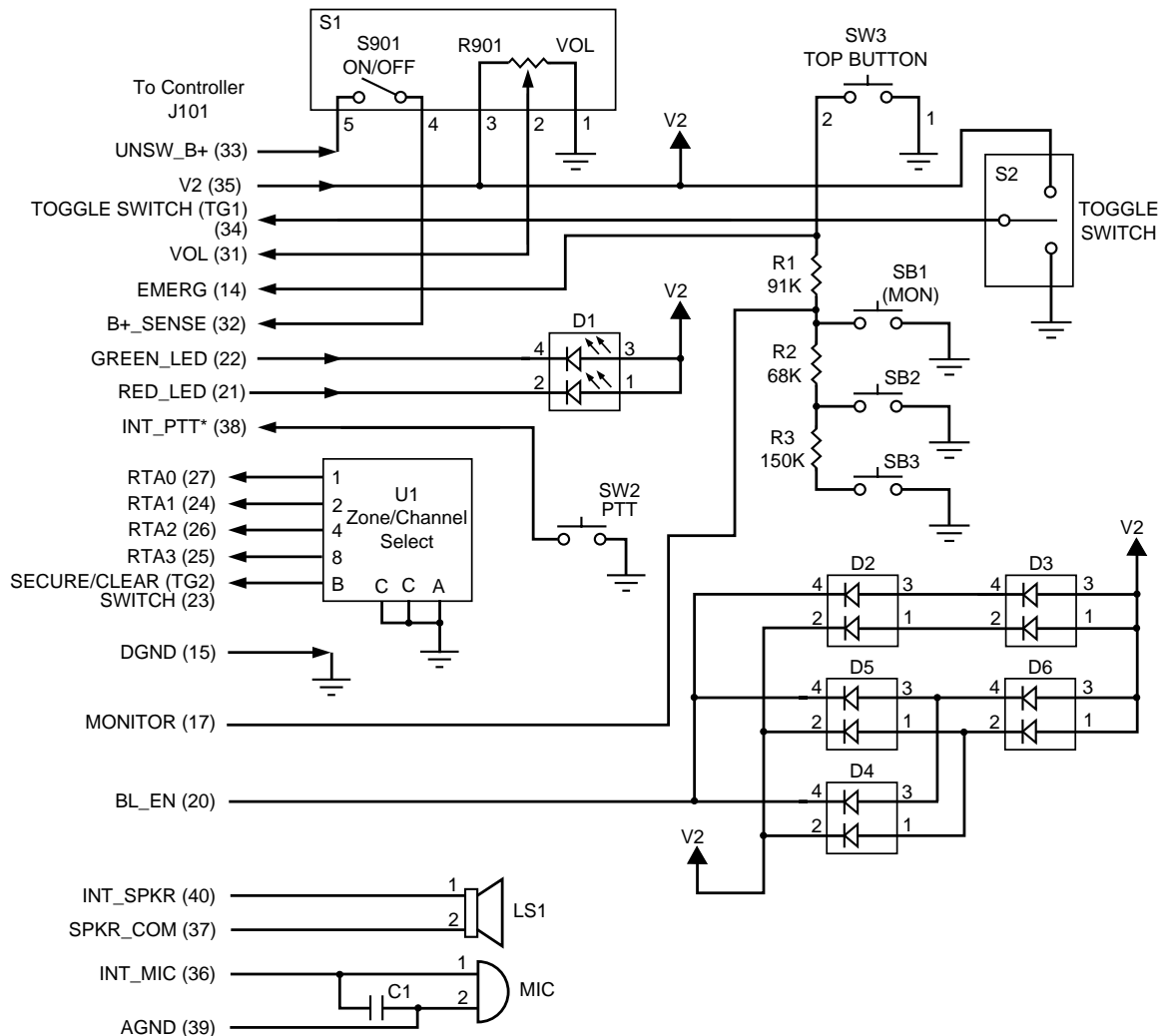

MAEPF-27416-A

Figure 3-11. Control Top Flex

### 3.2.4.7 System Clocks

The Patriot IC is supplied with two clocks. The first clock, a 16.8 MHz sine wave, comes from the RF interface connector P201 pin 7. It is conditioned by the clock buffer circuit, which includes Q450, Q451, L450, C450, C452, R450, R451, R452, R453, R454, and R455. The output of this buffer (C452) goes to the Patriot IC CKIH pin as well as the Flipper IC REF\_16\_IN (C307).

The other clock supplied to the Patriot IC is a 32.768 kHz square wave. This clock is generated by the Flipper IC internal oscillator and an external 32.768 kHz crystal Y301 and is connected to the Patriot IC CKIL pin.

### 3.2.5 VOCON Audio Paths

This section describes the VOCON transmit and receive audio paths. See Figure 8-67, "NTN9564B VOCON Audio and DC Circuits," on page 8-102 for schematic details of the following discussion.

#### 3.2.5.1 Transmit Audio Path

Refer to Figure 3-12. The internal microphone audio enters the VOCON board through the universal connector J101 pin 36, and the internal microphone bias is set by circuitry that includes R531, R533, C519 and C521. The internal microphone signal is connected to the MICIN\_NEG pin, which is the input terminal on the GCAP II IC internal op-amp A3. The gain of the A3 op-amp is set by the values of R540, R555, and the resistance of EEPOT U509 (digital potentiometer), which is programmed by Patriot IC GPIO lines.

The external microphone audio enters the VOCON board through the universal connector J101 pin 13, and the external microphone bias is set by circuitry that includes R563, R565, C547, and C548. The external microphone signal is connected to the AUX\_MIC\_NEG pin, which is an input terminal on the GCAP II IC internal op-amp A5. The gain of the A5 op-amp is set by the values of R566, R561, and the resistance of the EEPOT U509.

The Patriot IC, through the SPI bus, programs a multiplexer to select one of the microphone signals. Then, the selected amplified microphone signal goes through a programmable gain amplifier before it goes to the CODEC for A/D conversion. The resulting digital data is filtered and sent to the DSP on the SAP CODEC\_TX line from the GCAP II IC TX pin. After additional filtering and processing, the DSP sends the data-out from the STDB pin to the RF interface connector P201 pin 4 (TX\_DATA), which is connected to the DAC U203 on the transceiver board.

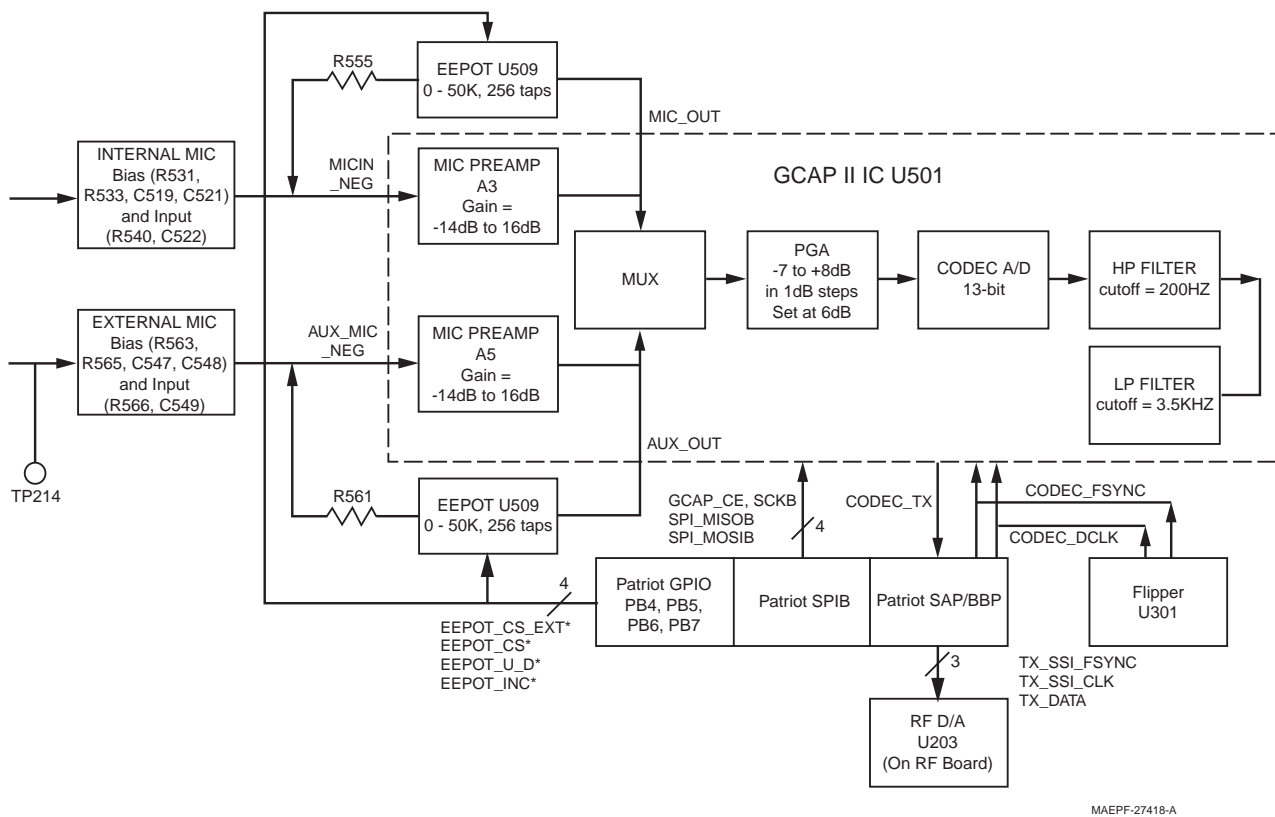
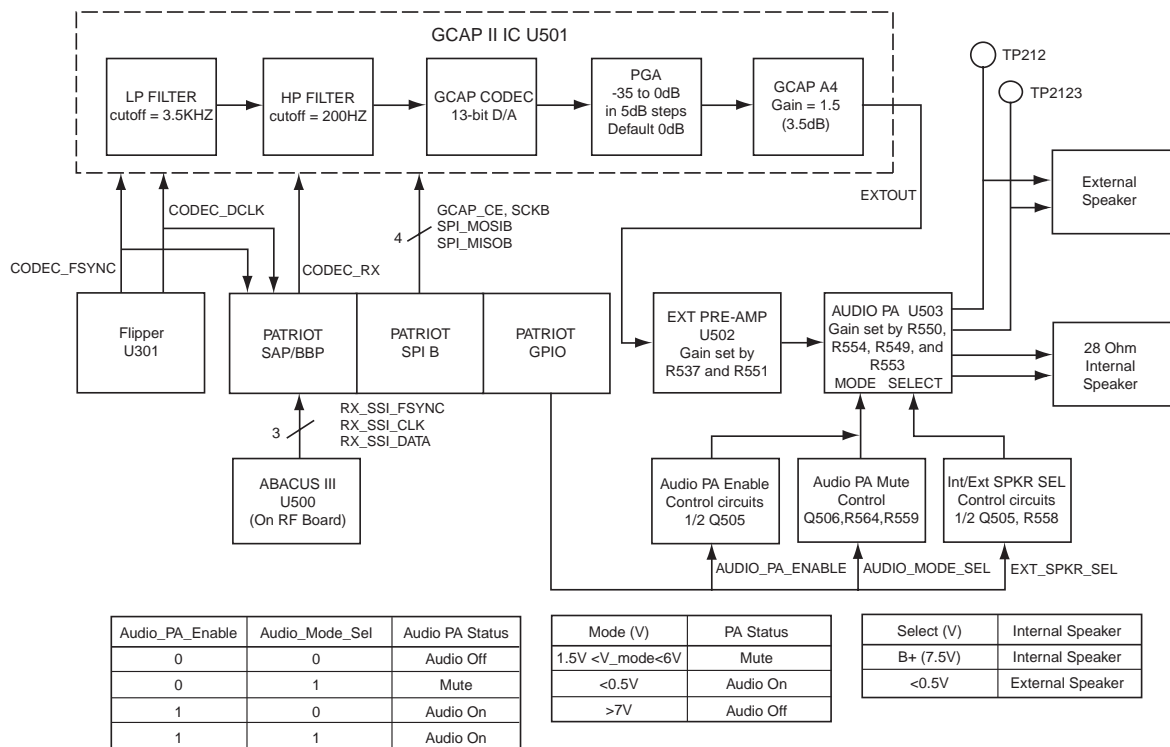

Figure 3-12. VOCON Transmit Audio Path

### 3.2.5.2 Receive Audio Path

Refer to [Figure 3-13](#). The receive audio data comes from the Abacus III IC U500 through the RF interface connector P201 pin 12 (RX\_DATA) to the Patriot IC SRDB pin. The DSP decodes the data and sends it out through the CODEC\_RX line to the GCAP II IC RX pin. The CODEC filters and converts the digital data into an analog audio signal, which, in turn, is sent to a programmable gain amplifier. The Patriot IC programs a multiplexer to route the audio signal to the A4 amplifier, which has a fixed gain of 3.5 dB. The output of the A4 amplifier is pin EXTOUT.

From the EXTOUT pin, the audio signal goes through the pre-amplifier U502 and then to the audio power amplifier U503, which together provide approximately 30 dB of gain. The Patriot IC selects whether the amplified audio is routed to the internal speaker or the external speaker.



MAEPF-27417-A

Figure 3-13. VOCON Receive Audio Path

### 3.2.6 Radio Power-Up/Power-Down Sequence

The radio power-up sequence begins when the user closes the radio On/Off switch on the control top, placing 7.5 Vdc on the B+SENSE line. This voltage enables the pass element Q501 and Q502, enabling SW\_B+ and GCAP\_B+.

When the GCAP II IC U501 detects a low-to-high voltage transition on GCAP\_B+, it turns on and enables voltage supplies VSW1, VSW2, V2 and Vref. As soon as these voltages come up, the 1.55 V regulator ramps up (only on the NNTN4717 VOCON board), and the Flipper IC U301 drives the WDI line high to enable VCC5 from regulator U505 and to maintain the GCAP II IC in the ON state. If WDI remains low, the GCAP II IC turns off 50 ms after turning on.

The radio power-down sequence begins by opening the radio On/Off switch, which removes the B+SENSE signal from the VOCON board. This does not immediately remove power because the GCAP II IC has control of Q502 through Vref, and U301 through WDI maintains the GCAP II IC in an active state. Both the MCU and Flipper IC monitor B+SENSE. After B+SENSE is removed, the Flipper IC waits 125 ms. before releasing WDI to allow for software cleanup; however, the software has the ability to prolong this time if it was necessary to complete its operations. When WDI is released, the GCAP II IC shuts down its supplies and the rest of the radio through Q501.

### 3.3 Encryption Module

The encryption module (secure models only) connects directly to the VOCON board and interfaces directly with the vocoder digital circuitry. It contains an independent microcontroller and two custom ICs to perform digital, numerical, encryption algorithms.

The encryption modules are designed to digitally encrypt and decrypt voice and ASTRO data in ASTRO XTS 5000 radios. This section covers the encryption modules, hardware kits **NTN9738** and **NNTN5032**.

**NOTE:** The encryption modules are NOT serviceable. The information contained in this section is only intended to help determine whether a problem is due to a encryption module or the radio itself.

The encryption module uses a custom encryption IC and an encryption key variable to perform its encode/decode function. The encryption key variable is loaded into the encryption module, via the radio's universal (side) connector, from a hand-held, key variable loader (KVL). The encryption IC corresponds to the particular encryption algorithm purchased. [Table 3-6](#) lists the encryption algorithms and their corresponding kit numbers.

Table 3-6. Encryption Module Software Kits and Algorithms

Software Kit Number	Algorithm
NNTN4006	DES, DES-XL, DES-OFB
NTN9837	DES, DES-XL, DES-OFB WITH DVP-XL
NTN9838	DVI-XL
NTN9839	DVP-XL
NNTN4197	AES
NNTN4198	AES with DES, DES-XL, DES-OFB

The encryption module operates from two power supplies (UNSW\_B+ and SW\_B+). The SW\_B+ is turned on and off by the radio's On/Off switch. The UNSW\_B+ provides power to the encryption module as long as the radio battery is in place.

Key variables are loaded into the encryption module through connector J701, pin 1. Depending on the type of encryption module, up to 16 keys can be stored in the module at a time. The key can be infinite key retention or 30-seconds key retention, depending on how the codeplug is set up.

The radio's host processor communicates with the encryption module on the Synchronous Serial Interface (SSI) bus. The SSI bus consists of five signal lines. A communications failure between the host processor and the secure module will be indicated as an *ERROR 09/10* message on the display.

To troubleshoot the encryption module, refer to the flowcharts in [Chapter 5 "Troubleshooting Charts."](#)

---

## Chapter 4 Troubleshooting Procedures

The purpose of this chapter is to aid in troubleshooting problems with the ASTRO XTS 5000 radio. It is intended to be detailed enough to localize the malfunctioning circuit and isolate the defective component. It also contains a listing of service tools recommended for PC board repair at the component level.



Caution

Most of the ICs are static sensitive devices. Do not attempt to disassemble the radio or troubleshoot a board without first referring to the following Handling Precautions section.

### 4.1 Handling Precautions

Complementary metal-oxide semiconductor (CMOS) devices, and other high-technology devices, are used in this family of radios. While the attributes of these devices are many, their characteristics make them susceptible to damage by electrostatic discharge (ESD) or high-voltage charges. Damage can be latent, resulting in failures occurring weeks or months later. Therefore, special precautions must be taken to prevent device damage during disassembly, troubleshooting, and repair. Handling precautions are mandatory for this radio, and are especially important in low-humidity conditions. DO NOT attempt to disassemble the radio without observing the following handling precautions.

1. Eliminate static generators (plastics, Styrofoam, etc.) in the work area.
  2. Remove nylon or double-knit polyester jackets, roll up long sleeves, and remove or tie back loose-hanging neckties.
  3. Store and transport all static-sensitive devices in ESD-protective containers.
  4. Disconnect all power from the unit before ESD-sensitive components are removed or inserted unless otherwise noted.
  5. Use a static-safeguarded workstation, which can be accomplished through the use of an anti-static kit (Motorola part number 01-80386A82). This kit includes a wrist strap, two ground cords, a static-control table mat and a static-control floor mat.
-

## 4.2 Recommended Service Tools

Table 4-1 lists recommended service tools that can be used for PC board repairs at the component level. For listings of additional service tools, service aids, and test equipment that are recommended for all levels of service, refer to the XTS 5000 basic service manual (see “[Related Publications](#)” on page xii).

Table 4-1. Recommended Service Tools

Motorola Part Number	Description	Application
R1453	Digital-readout solder station	Digitally controlled soldering iron
RLN4062	Hot-air workstation, 120V	Tool for hot-air soldering/desoldering of surface-mounted integrated circuits
0180386A78	Illuminated magnifying glass with lens attachment	Illumination and magnification of components
0180302E51	Master lens system	
0180386A82	Anti-static grounding kit	Used during all radio assembly and disassembly procedures
6684253C72	Straight prober	
6680384A98	Brush	
1010041A86	Solder (RMA type), 63/67, 0.5 mm diameter, 1 lb. spool	
0180303E45	SMD tool kit (included with R1319A)	
R1319	ChipMaster (110V)	Surface-mount removal and assembly of surface-mounted integrated circuits and/or rework station shields. Includes 5 nozzles.
R1321	ChipMaster (220V)	
R1364	Digital heated tweezer system	Chip component removal
R1427	Board preheater	Reduces heatsink on multi-level boards
6680309B53	Rework equipment catalog	Contains application notes, procedures, and technical references used to rework equipment
<b>ChipMaster Options:</b>		
6680370B54	0.710" x 0.710"	Heat-focus heads for R1319 workstation
6680370B57	0.245" x 0.245"	
6680370B58	0.340" x 0.340"	
6680371B15	0.460" x 0.560"	

Table 4-1. Recommended Service Tools (Continued)

Motorola Part Number	Description	Application
<b>ChipMaster Nozzles:</b>		
6680333E28	PA nozzle	Soldering and unsoldering ICs
6680332E83	PLCC-28* nozzle	
6680332E93	PLCC-32 nozzle	
6680332E82	PLCC-44* nozzle	
6680332E94	PLCC-52 nozzle	
6680332E95	PLCC-68* nozzle	
6680332E96	PLCC-84 nozzle	
6680332E89	QFP-80 nozzle	
6680332E90	QFP-100* nozzle	
6680332E91	QFP-132* nozzle	
6680334E67	QFP-160 nozzle	
6680332E86	SOIC-14/SOL-16J nozzle	
6680333E46	SOL-18 nozzle	
6680332E84	SOIC-20 nozzle	
6680332E87	SOL-20J nozzle	
6680333E45	SOL-24 nozzle	
6680332E88	SOL-28J nozzle	
6680333E54	TSOP-32 nozzle	
6680333E55	TSOP-64 nozzle	

\* Included with ChipMaster packages

### 4.3 Voltage Measurement and Signal Tracing

It is always a good idea to check the battery voltage under load. This can be done by checking the OPT\_B+\_VPP pin at the side connector (pin 4). The battery voltage should remain at or above 7.0 Vdc. If the battery voltage is less than 7.0 Vdc, then it should be recharged or replaced as necessary prior to analyzing the radio.

In most instances, the problem circuit may be identified using a multimeter, an RF millivoltmeter, oscilloscope (preferably with 100 MHz bandwidth or more), and a spectrum analyzer.

 <p><b>Caution</b></p>	<p>When checking a transistor or module, either in or out of circuit, do not use an ohmmeter having more than 1.5 Vdc appearing across test leads or use an ohms scale of less than x100.</p>
---	---

## 4.4 Standard Bias Table

Table 4-2 outlines some standard supply voltages and system clocks which should be present under normal operation. These should be checked as a first step to any troubleshooting procedure.

Table 4-2. Standard Operating Bias

Signal Name	Nominal Value	Tolerance	VOCON Board Source
13 MHz	13 MHz	±1000 ppm	C303 (NTN9564) C339 (NNTN4563, NNTN4819 & NNTN4717)
FLIP_32K	32.768 kHz	±400 ppm	U302, pin2 (under shield SH102 on NNTN4563, NNTN4819 & NNTN4717)
SINE32K	32.768 kHz	±400 ppm	C313 (NTN9564) C306 (NNTN4563, NNTN4819 & NNTN4717)
CKIH	16.8 MHz		R452 (under shield SH101 on NNTN4563, NNTN4819 & NNTN4717 or test fixture pin 7 on the board-to-board connector)
16_8MHz	16.8 MHz		C452 (under shield SH101 on NNTN4563, NNTN4819 & NNTN4717)
POR	3.0 Vdc	±5%	POR test point
RESET_OUT	3.0 Vdc	±5%	RESET_OUT test point (NTN9564) D401, pin 3 (NNTN4563, NNTN4819 & NNTN4717)
VSW1	3.85 Vdc	±5%	R502
VSW2	1.85 Vdc	±5%	R501
FILT_B+	7.5 Vdc	6.0-9.0 Vdc	C523
V2	3.0 Vdc* 2.9 Vdc**	±5%	R560
GCAP_B+	7.5 Vdc	6.0-9.0 Vdc	R581
UNSW_B+	7.5 Vdc	6.0-9.0 Vdc	B104
SW_B+	7.5 Vdc	6.0-9.0 Vdc	R587
VCC5	5.0 Vdc	±5%	R503
VSW_1_55 V	1.55 Vdc	±5%	R407 (NNTN4717 VOCON kit only)

\* = NTN9564, NNTN4563, & NNTN4819 VOCON kits

\*\* = NNTN4717 VOCON kit



## 4.5 Power-Up Self-Check Errors

Each time the radio is turned on, the MCU and DSP perform a series of internal diagnostics. These diagnostics consist of checking such programmable devices as the FLASH ROMs, the EEPROM, and SRAM devices.

Problems detected during the power-up self-check routines are presented as error codes on the radio's display. For non-display radios, the problem is presented at power up by a single, low-frequency tone. [Table 4-3](#) lists possible error codes, a description of each error code, and a recommended corrective action.

*Table 4-3. Power-Up Self-Check Error Codes*

<b>Error Code</b>	<b>Description</b>	<b>Corrective Action</b>
01/02	FLASH ROM codeplug Checksum Non-Fatal Error	Reprogram the codeplug
01/12	Security Partition Checksum Non-Fatal Error	Send radio to depot
01/20	ABACUS Tune Failure Non-Fatal Error	Turn radio off, then on
01/22	Tuning Codeplug Checksum Non-Fatal Error	Send radio to depot
01/81	Host ROM Checksum Fatal Error	Send radio to depot
01/82	FLASH ROM Codeplug Checksum Fatal Error	Reprogram the codeplug
01/88	External RAM Fatal Error — Note: Not a checksum error	Send radio to depot
01/90	General Hardware Failure Fatal Error	Turn radio off, then on
01/92	Security Partition Checksum Fatal Error	Send radio to depot
01/93	FLASHport Authentication Code Failure	Send radio to depot
01/98	Internal RAM Fail Fatal Error	Send radio to depot
01/A2	Tuning Codeplug Checksum Fatal Error	Send radio to depot
02/81	DSP ROM Checksum Fatal Error	Send radio to depot
02/88	DSP RAM Fatal Error — Note: Not a checksum error	Turn radio off, then on
02/90	General DSP Hardware Failure (DSP startup message not received correctly)	Turn radio off, then on
09/10	Secure Hardware Failure	Turn radio off, then on
09/90	Secure Hardware Fatal Error	Turn radio off, then on

## 4.6 Power-Up Self-Check Diagnostics and Repair (Not for Field Use)

Table 4-4 lists additional action items that can be used for the diagnosis and resolution of the error codes listed in Table 4-3 on page 4-5.

Table 4-4. Power-Up Self-Check Diagnostic Actions

Error Code	Diagnostic Actions
01/02	This non-fatal error will likely recover if the radio's power is cycled. In the event that this does not resolve the issue, the radio should be reflashed. As a last resort, the FLASH ROM U402 should be replaced.
01/12	The radio should be sent to the depot for reflashing of the security codeplug.
01/20	Cycling radio power should resolve this issue.
01/22	The radio should be sent to the depot for reflash of the tuning codeplug followed by retuning of the radio.
01/81	The radio should be sent to the depot for reflashing of the host code.
01/82	The radio should be sent to the depot for reflashing of the radio codeplug.
01/88	Reflashing of the radio should first be performed. If this fails to resolve the issue, then replacement of the SRAM U403 is necessary.
01/90	Cycle power to radio. Continued failure indicates a likely IC failure (GCAP, PCIC, FLIPPER, ABACUS). In this event, radio should be sent to the depot for isolation and repair of the problem IC.
01/92	The radio should be sent to the depot for reprogramming of the security codeplug.
01/93	The radio should be sent to the depot for reflashing of the host code.
01/98	Send radio to the depot for replacement of the SRAM U403.
01/A2	The radio should be sent to the depot for reflashing of the tuning codeplug followed by re-tuning of the radio.
02/81	The radio should be sent to the depot for examination and/or replacement of either the FLASH U402, or the PATRIOT MCU/DSP U401.
02/88	Cycle power to the radio. If this does not fix the problem, then the radio should be sent to the depot for reflashing of the DSP code. Continued failure requires examination and/or replacement of the SRAM U403.
02/90	Cycle power to the radio. If this fails to fix the problem, then the radio should be sent to the depot for reflashing of the DSP code. Continued failure may require replacement of U401, the PATRIOT MCU/DSP.
09/10	Cycle power to the radio. If this fails then follow instructions in the secure hardware failure troubleshooting flowchart.
09/90	Cycle power to the radio. If this fails then follow instructions in the secure hardware failure troubleshooting flowchart.

---

## Chapter 5 Troubleshooting Charts

This section contains detailed troubleshooting flowcharts. These charts should be used as a guide in determining the problem areas. They are not a substitute for knowledge of circuit operation and astute troubleshooting techniques. It is advisable to refer to the related detailed circuit descriptions in the theory of operation sections prior to troubleshooting a radio.

### 5.1 List of Troubleshooting Charts

Most troubleshooting charts (see [Table 5-1](#)) end up by pointing to an IC to replace. **It is not always noted, but it is good practice to verify supplies and grounds to the affected IC and to trace continuity to the malfunctioning signal and related circuitry before replacing any IC.** For instance, if a clock signal is not available at a destination, continuity from the source IC should be checked before replacing the source IC.

*Table 5-1. Troubleshooting Charts List*

Chart Title	Page Number
<a href="#">Main Troubleshooting Flowchart</a>	<a href="#">5-2</a>
<a href="#">Power-Up Failure</a>	<a href="#">5-3</a>
<a href="#">DC Supply Failure</a>	<a href="#">5-5</a>
<a href="#">Display Failure (NNTN4563, NNTN4819, &amp; NNTN4717 VOCON Kits)</a>	<a href="#">5-8</a>
<a href="#">Display Failure (NTN9564)</a>	<a href="#">5-11</a>
<a href="#">Volume Set Error</a>	<a href="#">5-14</a>
<a href="#">Channel/Zone Select Error</a>	<a href="#">5-15</a>
<a href="#">Button Test</a>	<a href="#">5-16</a>
<a href="#">Top/Side Button Test</a>	<a href="#">5-17</a>
<a href="#">VCO TX/RX Unlock</a>	<a href="#">5-18</a>
<a href="#">VOCON TX Audio—Page 1</a>	<a href="#">5-19</a>
<a href="#">VOCON RX Audio</a>	<a href="#">5-21</a>
<a href="#">RX RF</a>	<a href="#">5-23</a>
<a href="#">TX RF (VHF and UHF Range 2)</a>	<a href="#">5-28</a>
<a href="#">TX RF (UHF R1/700-800 MHz)</a>	<a href="#">5-31</a>
<a href="#">Keyload Failure</a>	<a href="#">5-34</a>
<a href="#">Secure Hardware Failure</a>	<a href="#">5-35</a>

---

## 5.2 Main Troubleshooting Flowchart

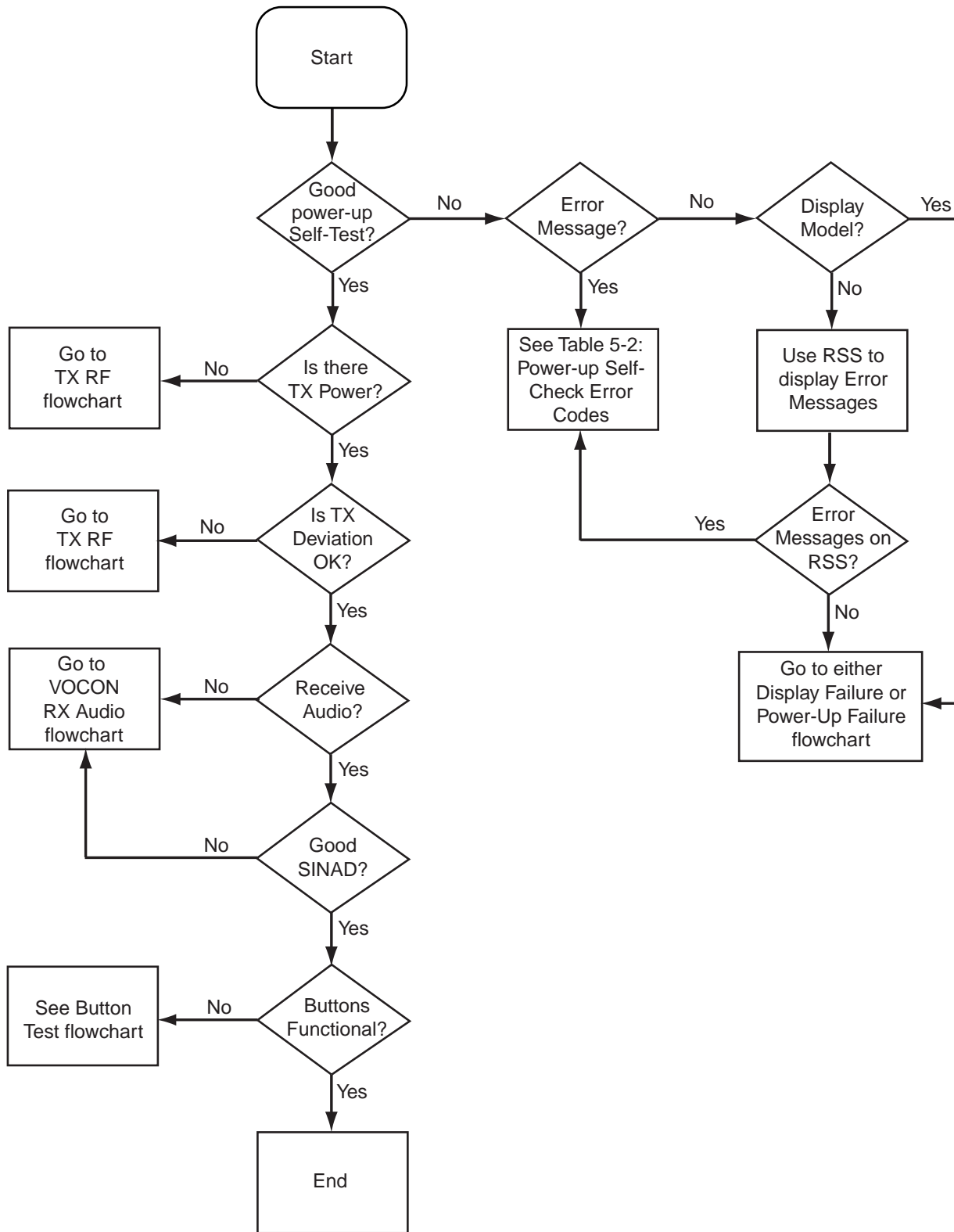

### 5.3 Power-Up Failure—Page 1

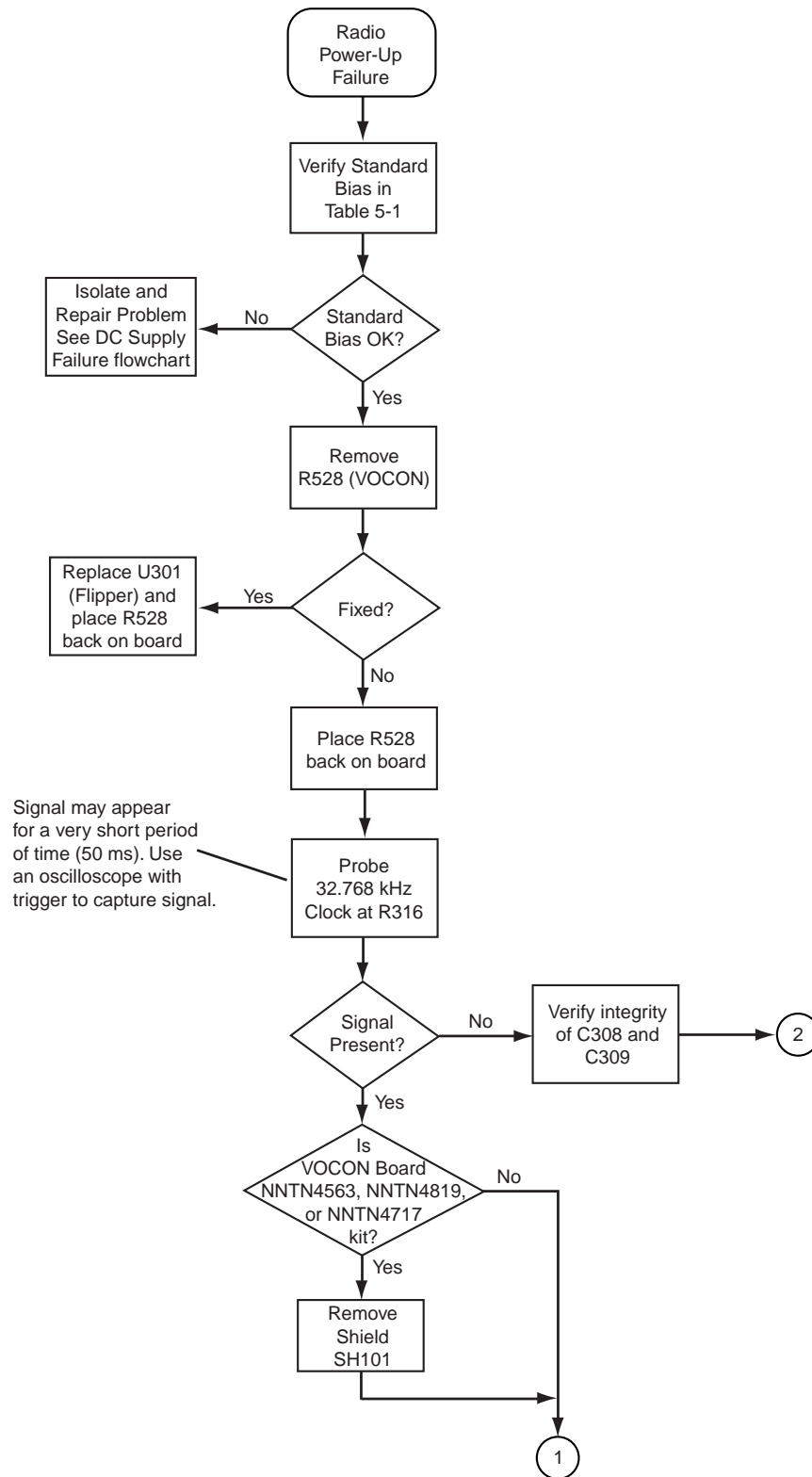

MAEPF-27389-C

# Power-Up Failure—Page 2

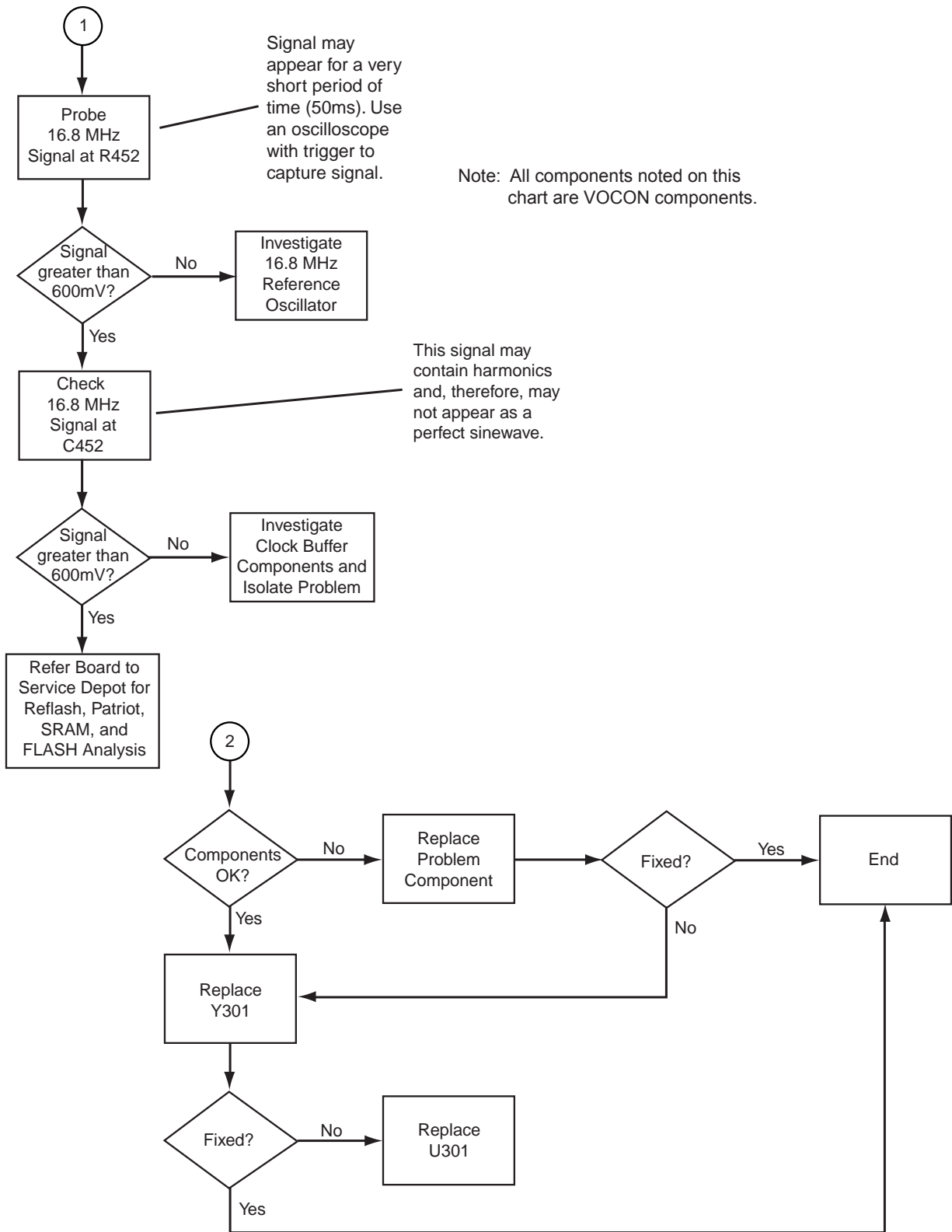

MAEPF-27390-A

## 5.4 DC Supply Failure—Page 1

**NOTE:** Since the failure of a critical voltage supply might cause the radio to automatically power down, supply voltages should first be probed with a multimeter. If all the board voltages are absent, then the voltage test point should be retested using a rising-edge-triggered oscilloscope. If the voltage is still absent, then another voltage should be tested using the oscilloscope. If that voltage is present, then the original voltage supply in question is defective and requires investigation of associated circuitry.

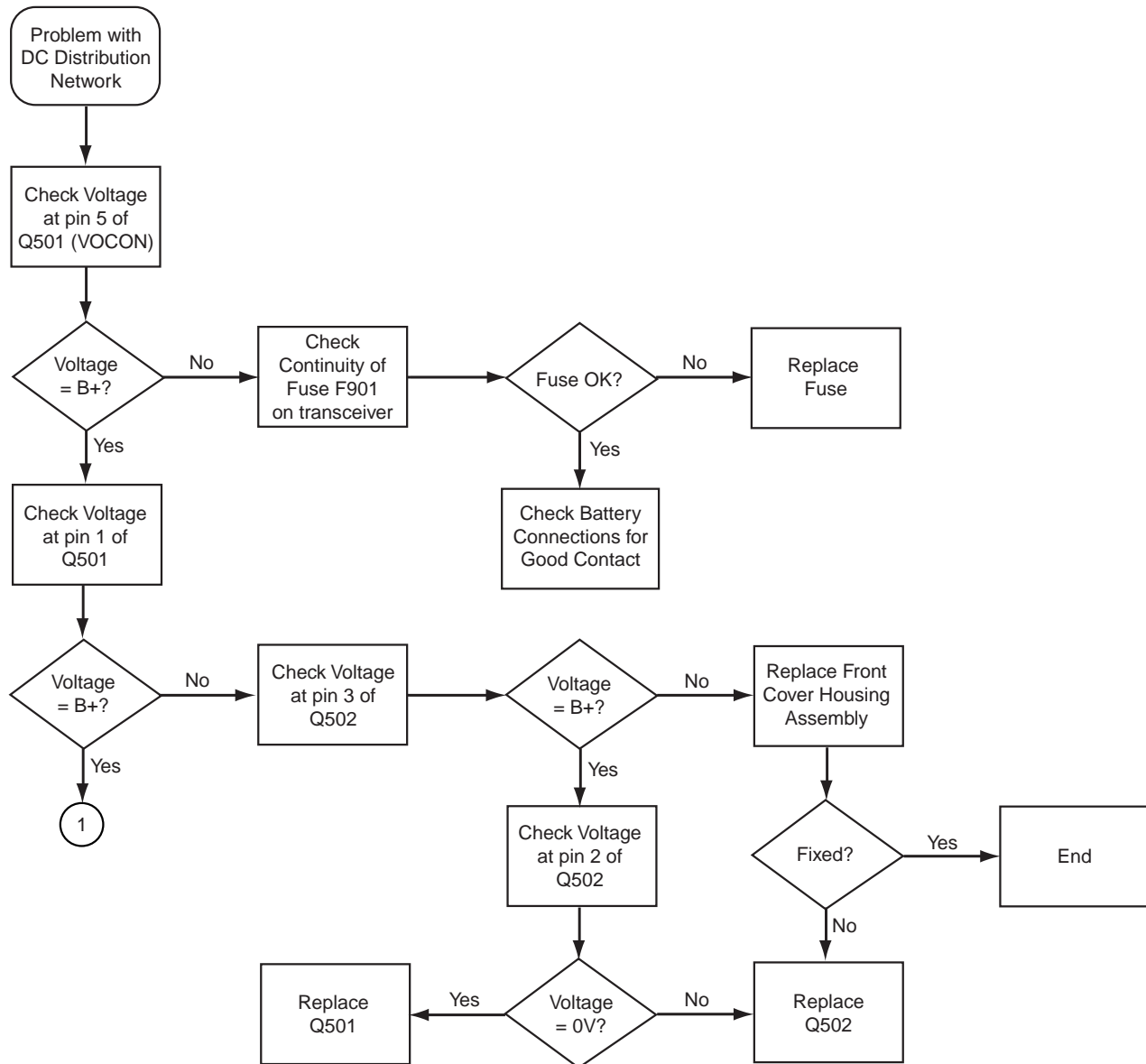

MAEPF-27391-A

# DC Supply Failure—Page 2

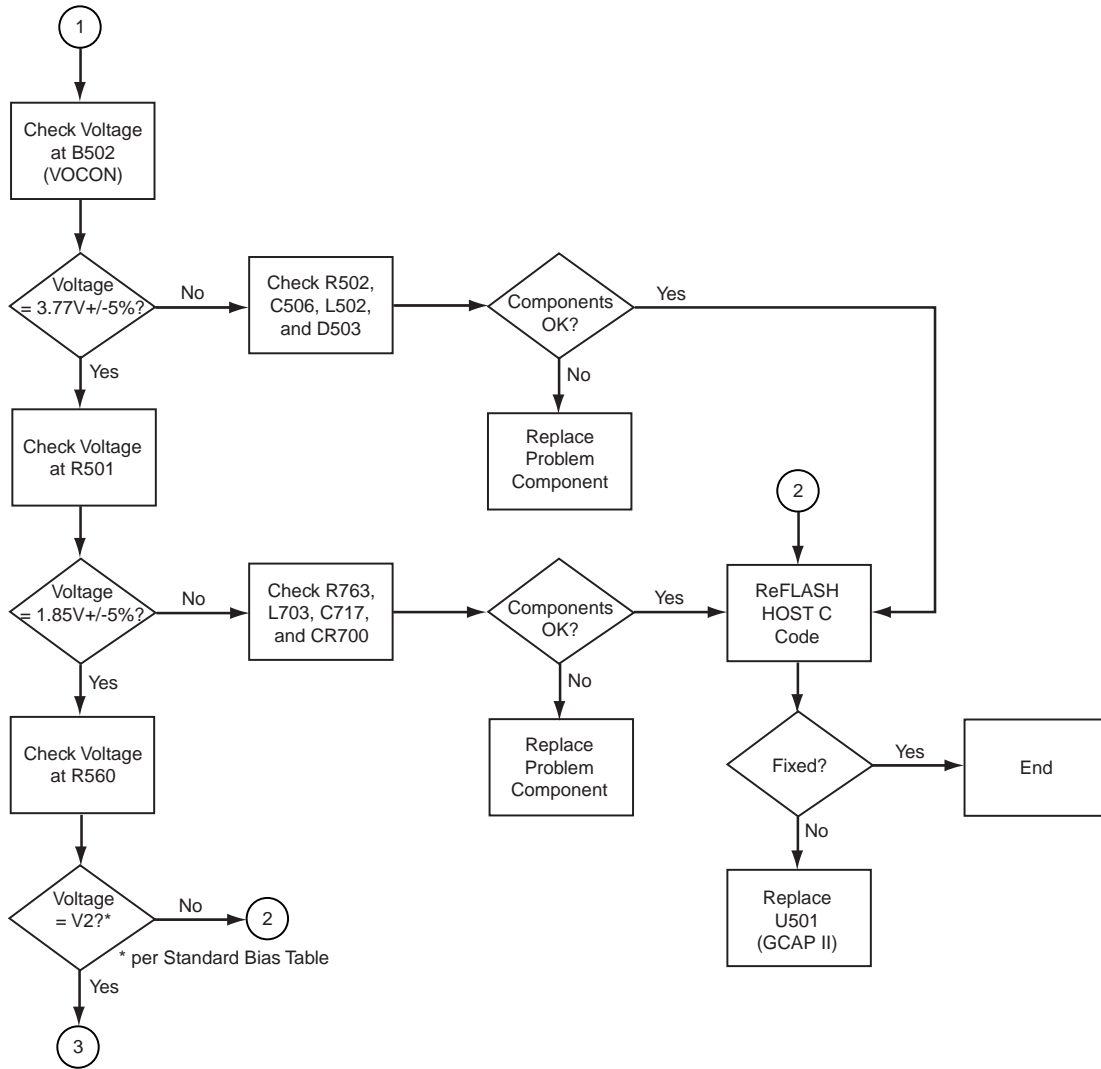

MAEPF-27392-B



# DC Supply Failure—Page 3

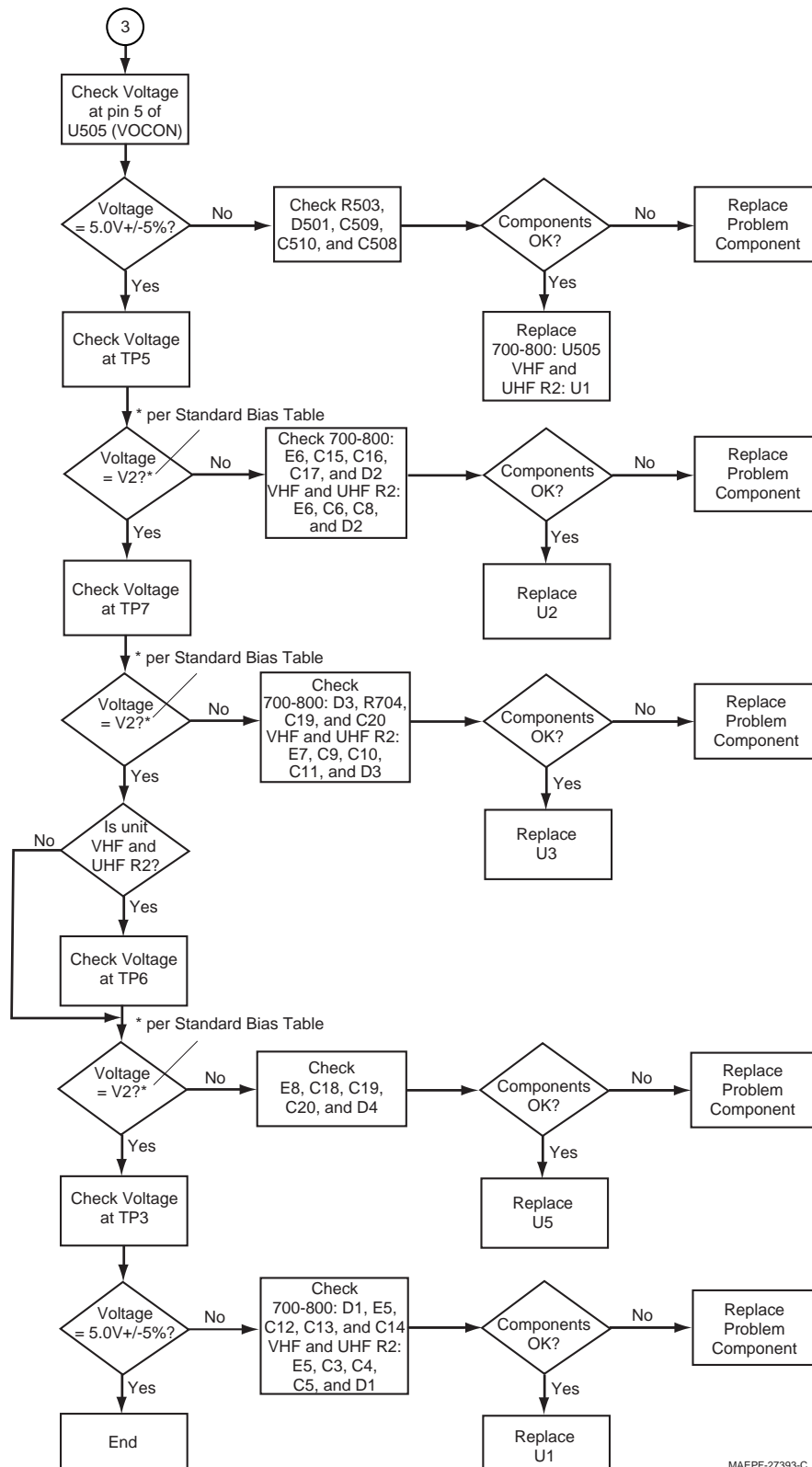

MAEPF-27393-C

## 5.5 Display Failure (NNTN4563, NNTN4819, & NNTN4717 VOCON Kits) Page 1

**NOTE:** The NNTN4563 VOCON board is compatible only with the 7285726C02 display module, and the NNTN4819 VOCON board is compatible only with the 7285726C03 display module.

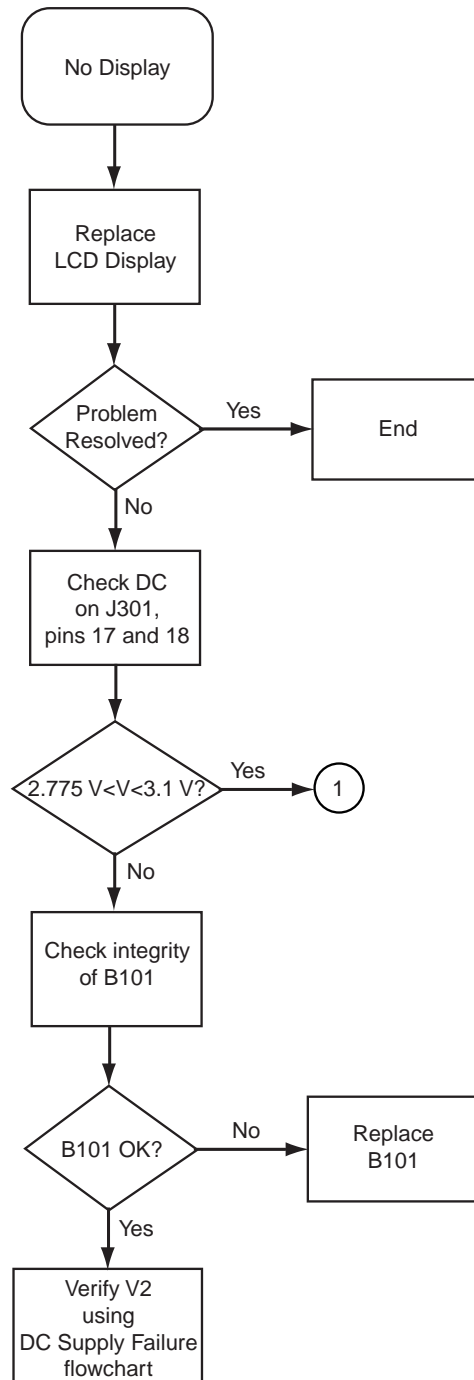

MAEPF-27505-B

# Display Failure (NNTN4563, NNTN4819, & NNTN4717 VOCON Kits) Page 2

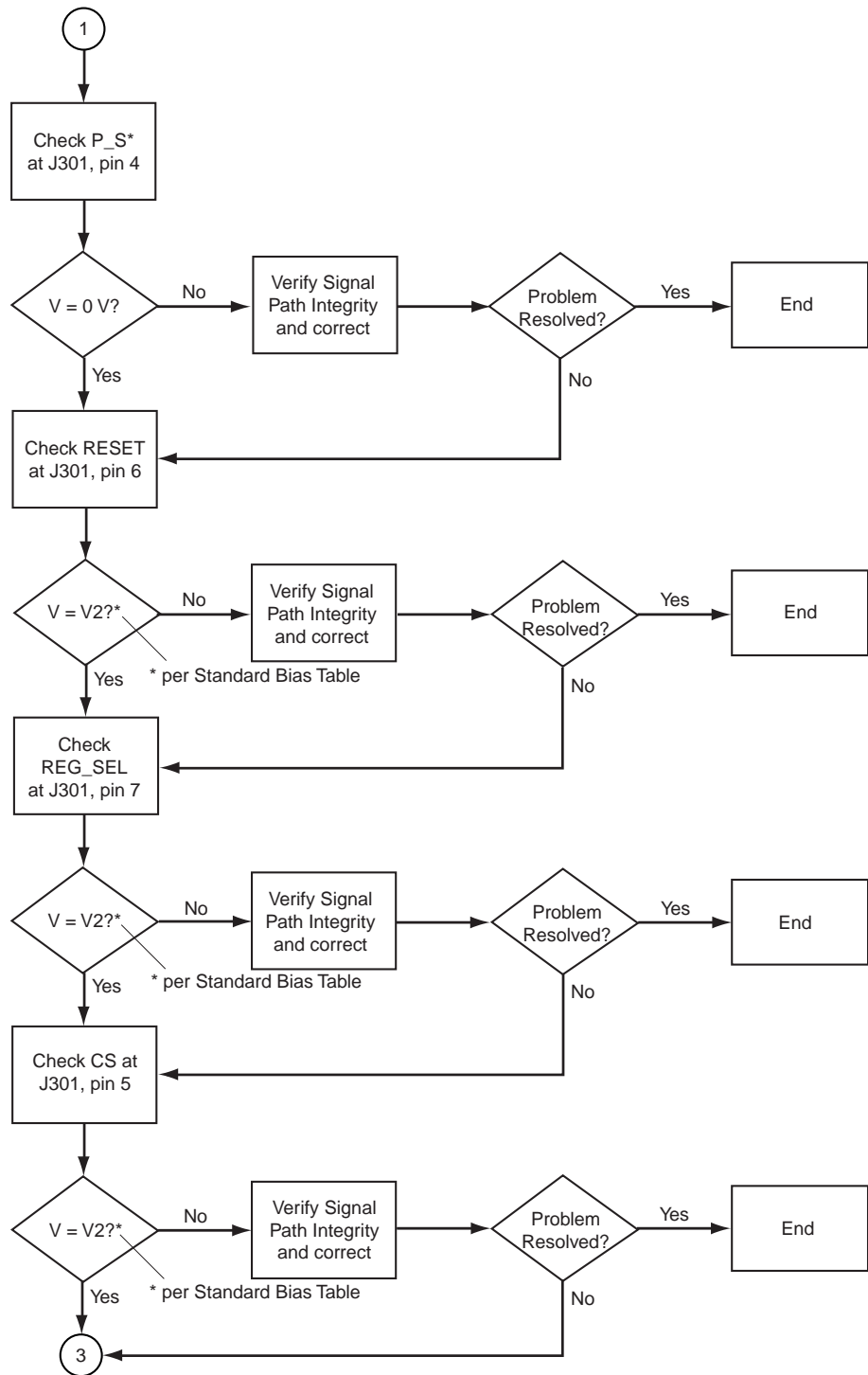

MAEPF-27506-A

# Display Failure (NNTN4563, NNTN4819, & NNTN4717 VOCON Kits) Page 3

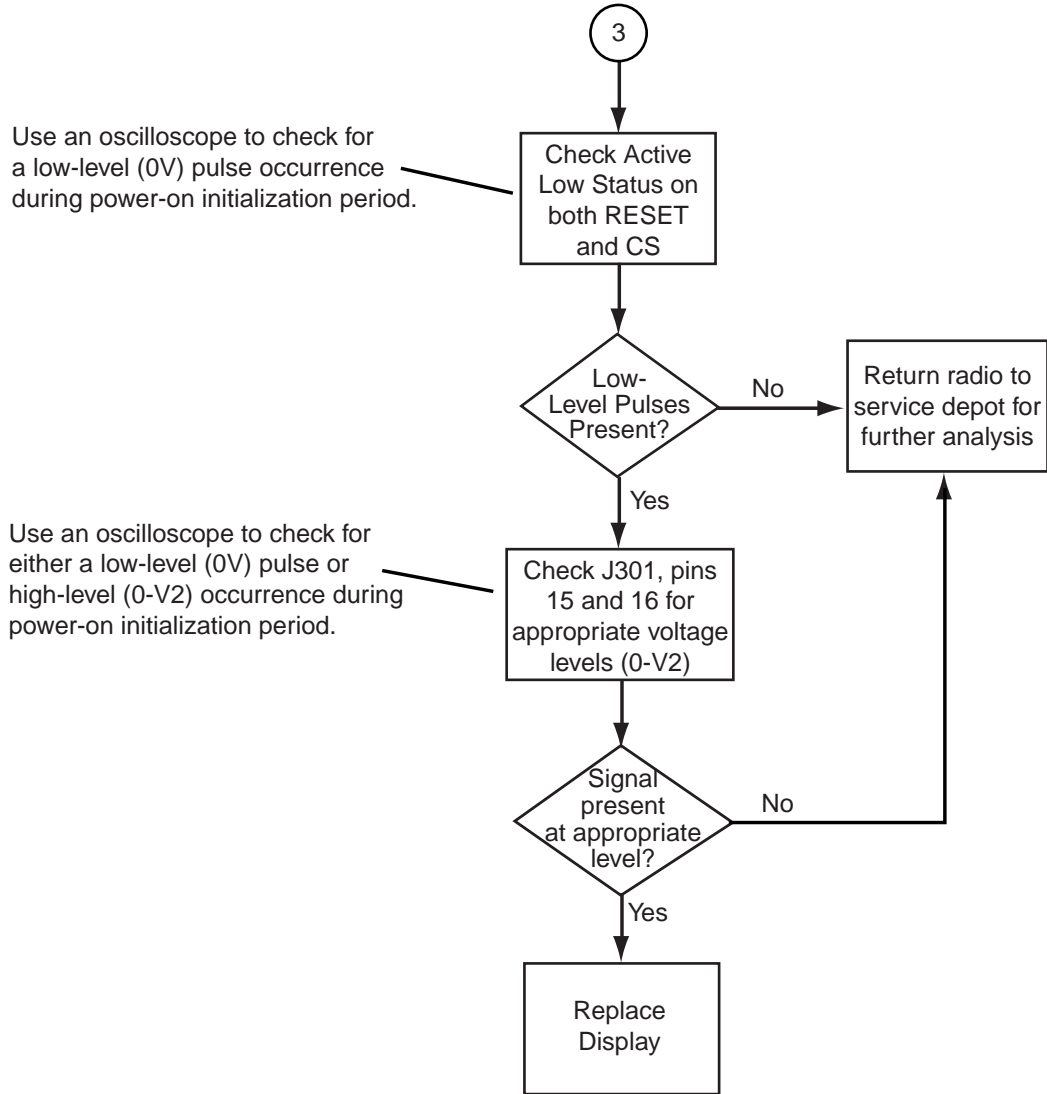

MAEPF-27507-A

## 5.6 Display Failure (NTN9564)—Page 1

**NOTE:** The NTN9564 VOCON board is compatible only with the 7285726C01 display module.

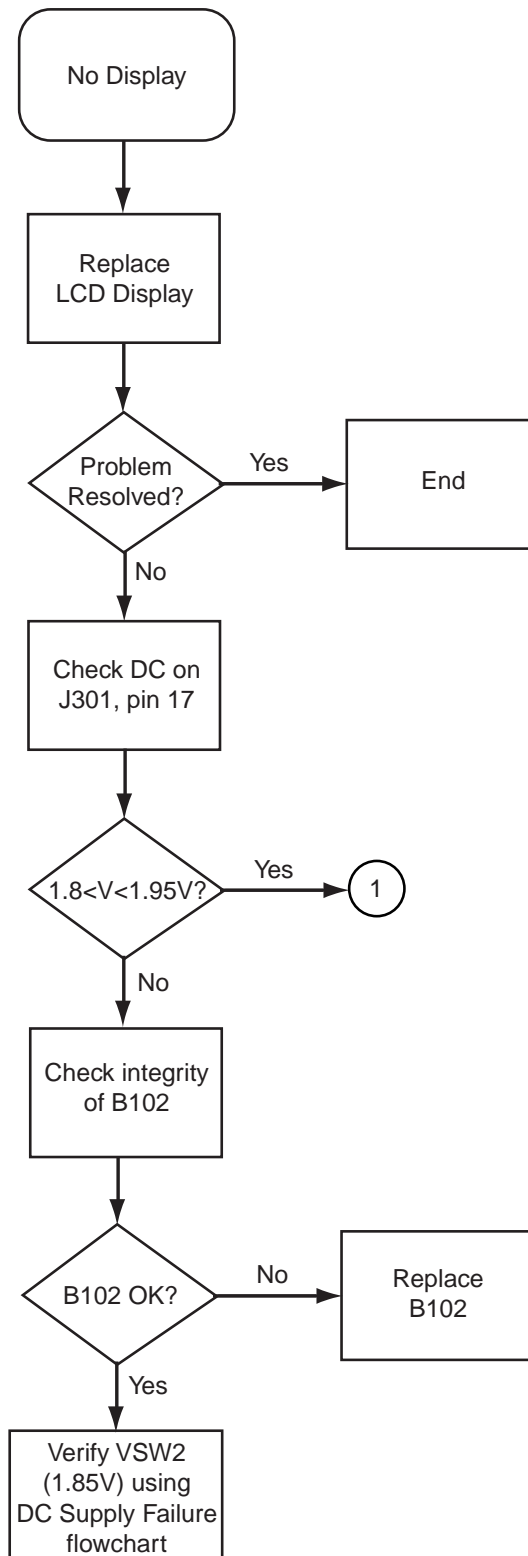

MAEPF-27404-O

### Display Failure (NTN9564)—Page 2

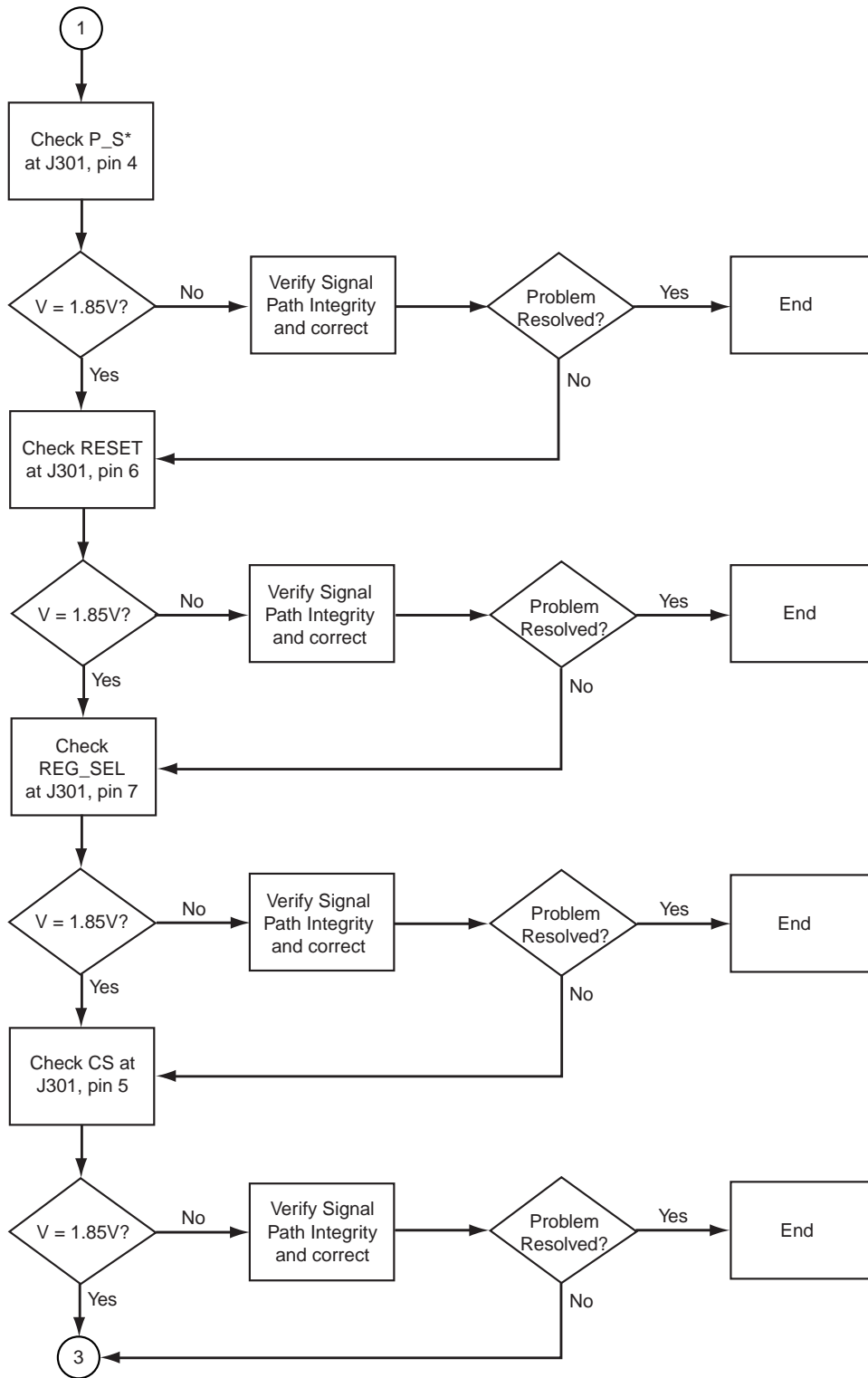

MAEPF-27405-O

### Display Failure (NTN9564)—Page 3

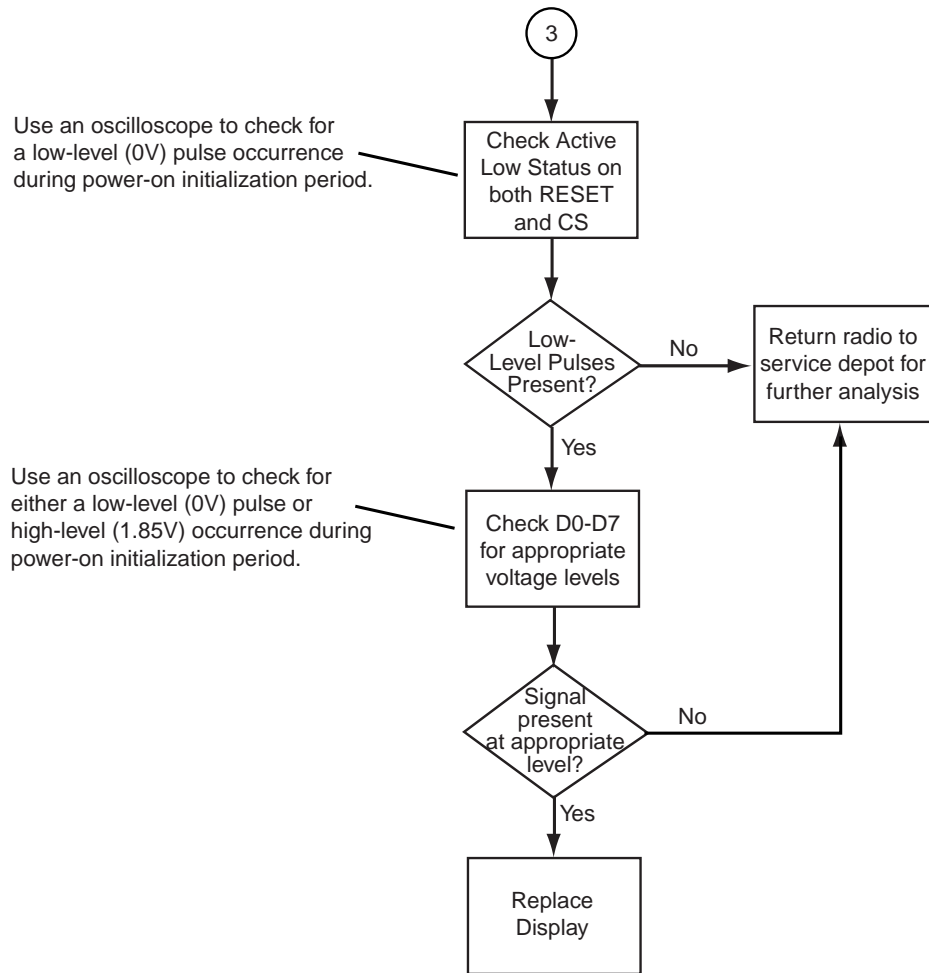

MAEPF-27406-O

### 5.7 Volume Set Error

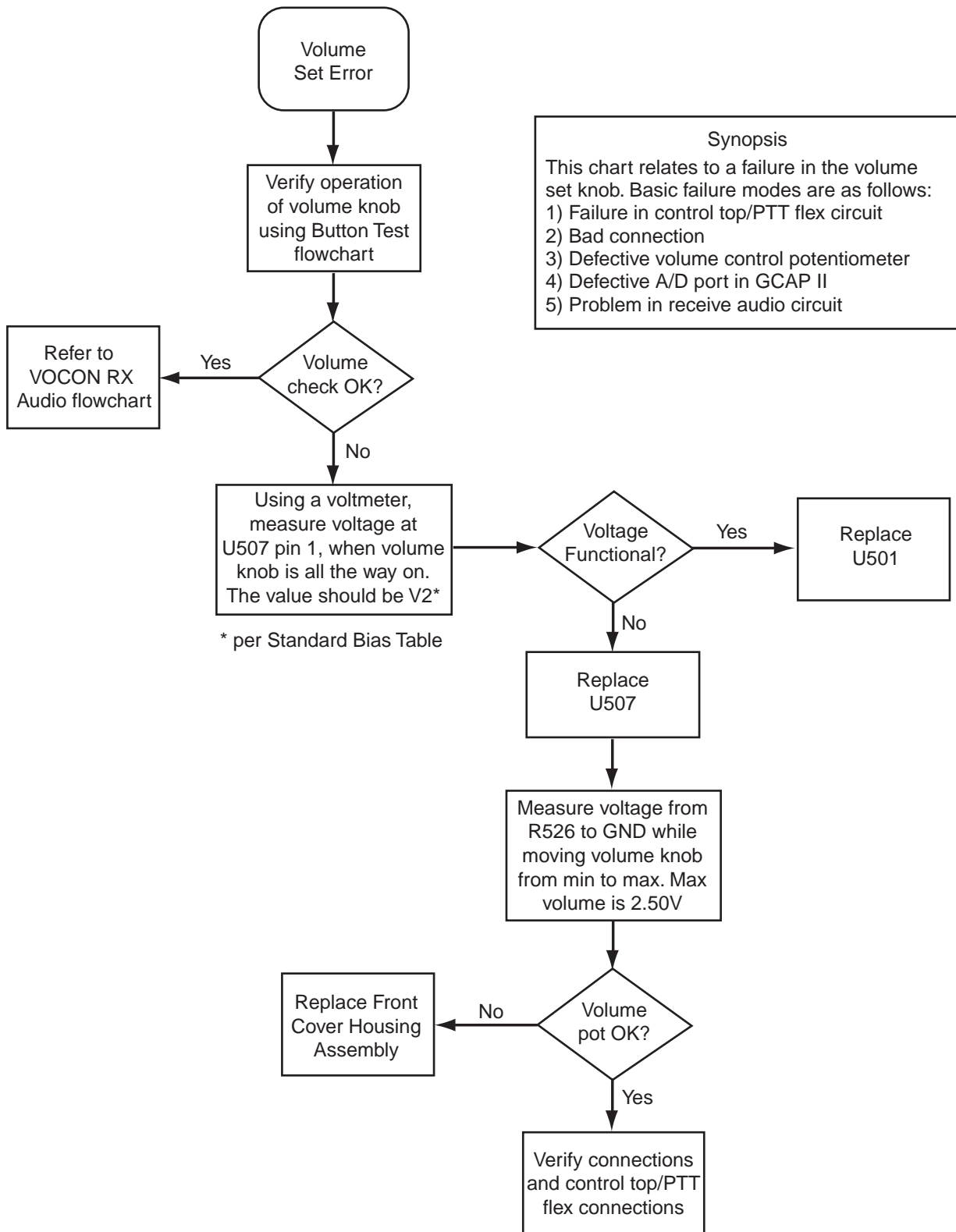

MAEPF-27401-A



## 5.8 Channel/Zone Select Error

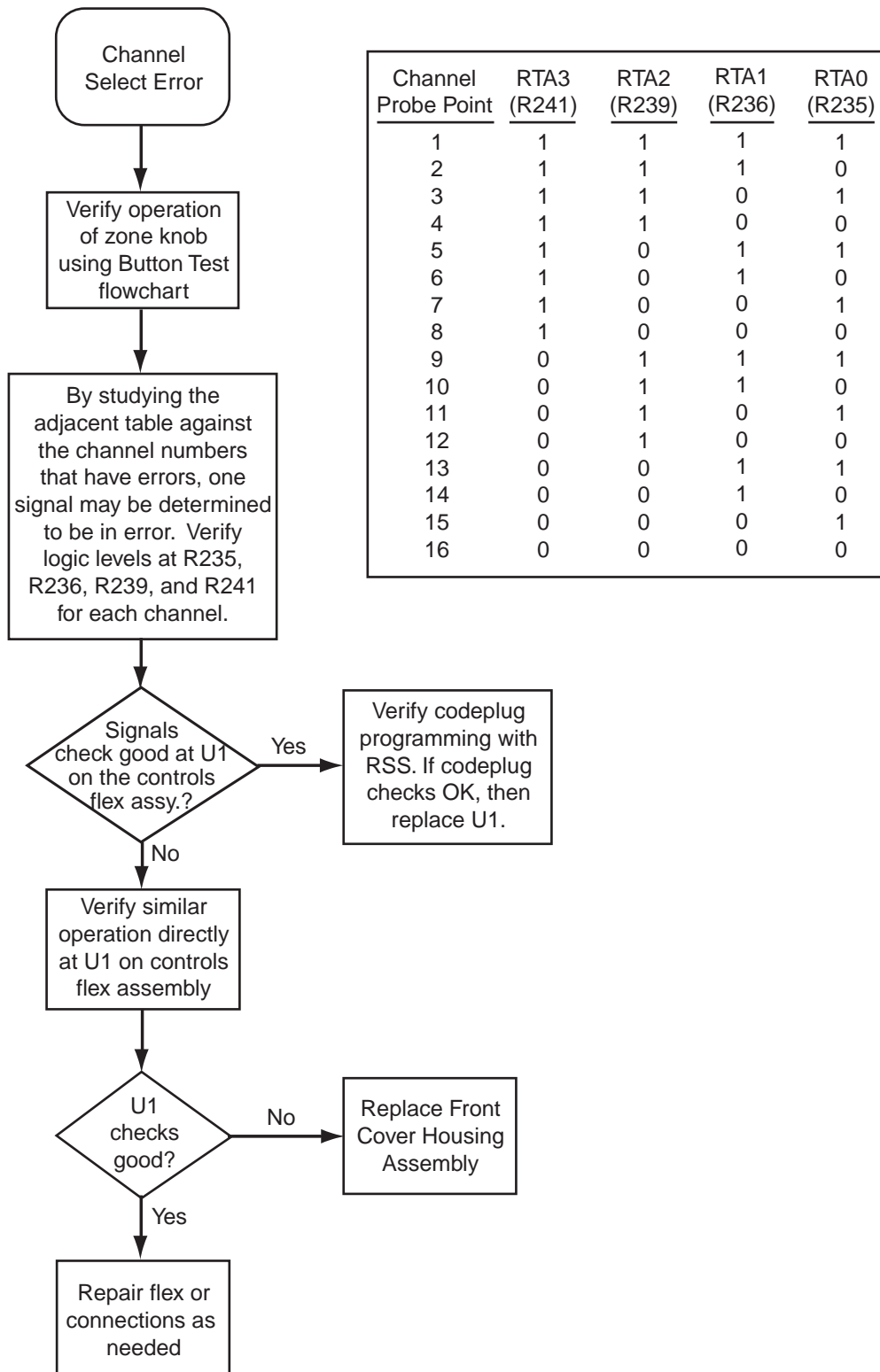

MAEPF-27402-O

## 5.9 Button Test

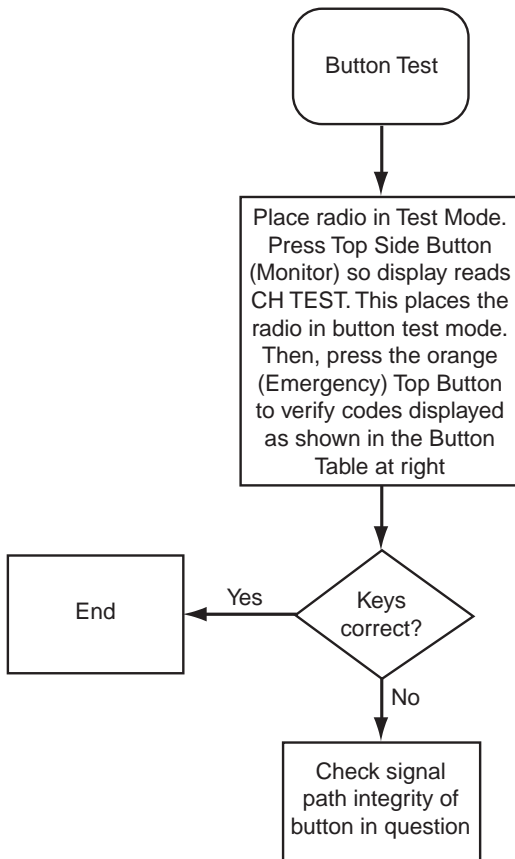

**Synopsis**

This chart relates to a failure in the button functions  
 Basic Failure modes are as follows:

- 1) Failure in control top/PTT or keypad flex assembly
- 2) Bad Connection
- 3) Defective Switches or pads
- 4) Defective A/D port in GCAP II

**Button Table**

Button	Code
PTT	1/ 0-1
Top Button (Emergency)	3/ 0-1
Side Button 1 (Monitor)	96/ 0-1
Side Button 2	97/ 0-1
Side Button 3	98/ 0-1
Channel Select (Frequency)	4/ 0-15
Volume Control Knob	0/ 0-244
Zone Select	65/ 0-2

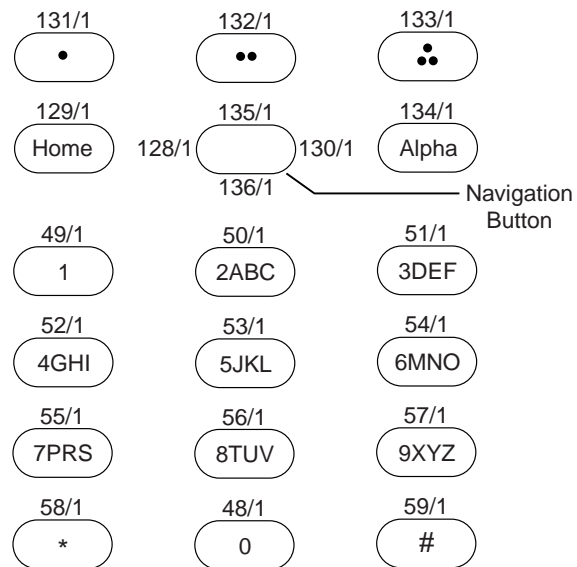

MAEPF-27399-O

## 5.10 Top/Side Button Test

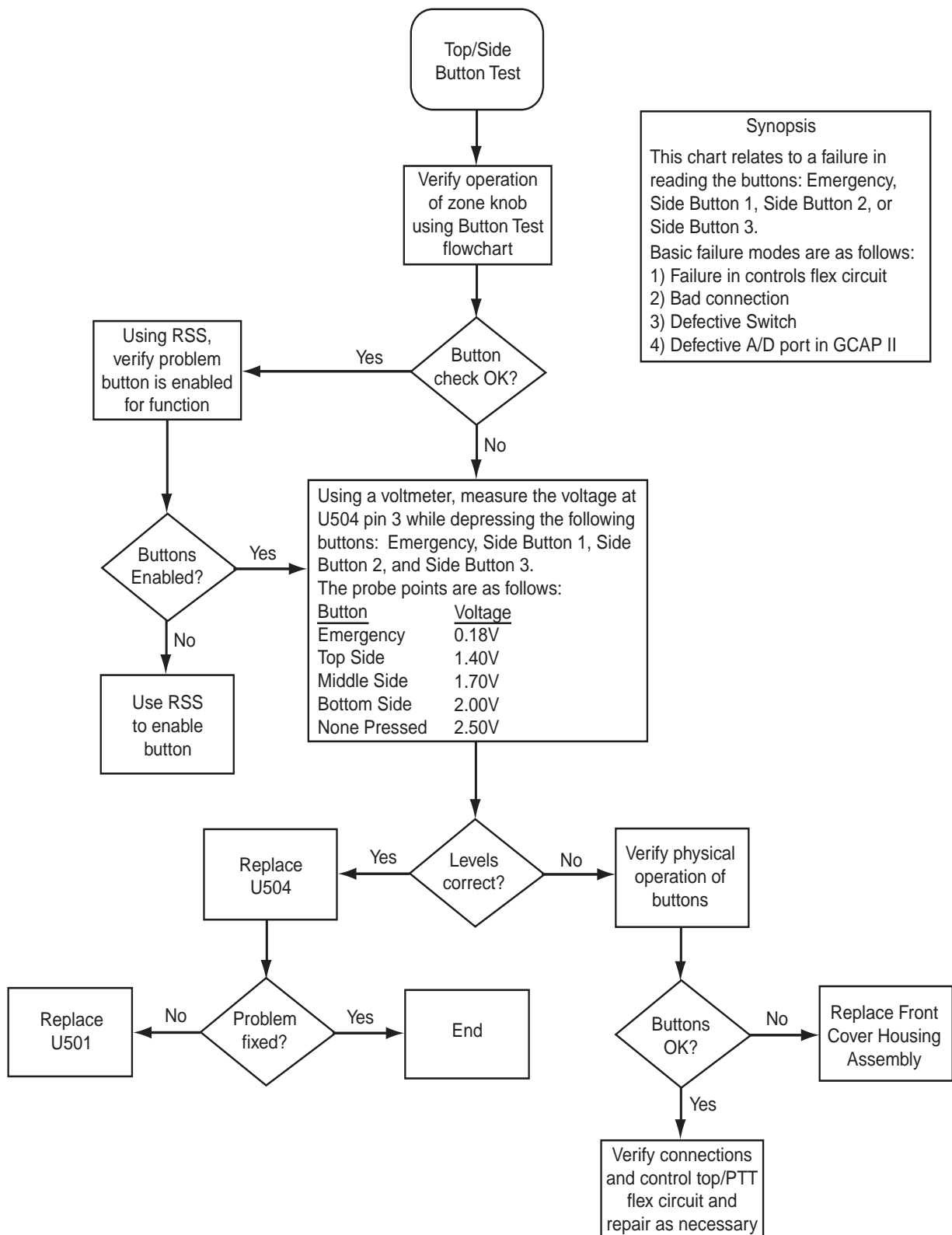

MAEPF-27400-O

### 5.11 VCO TX/RX Unlock

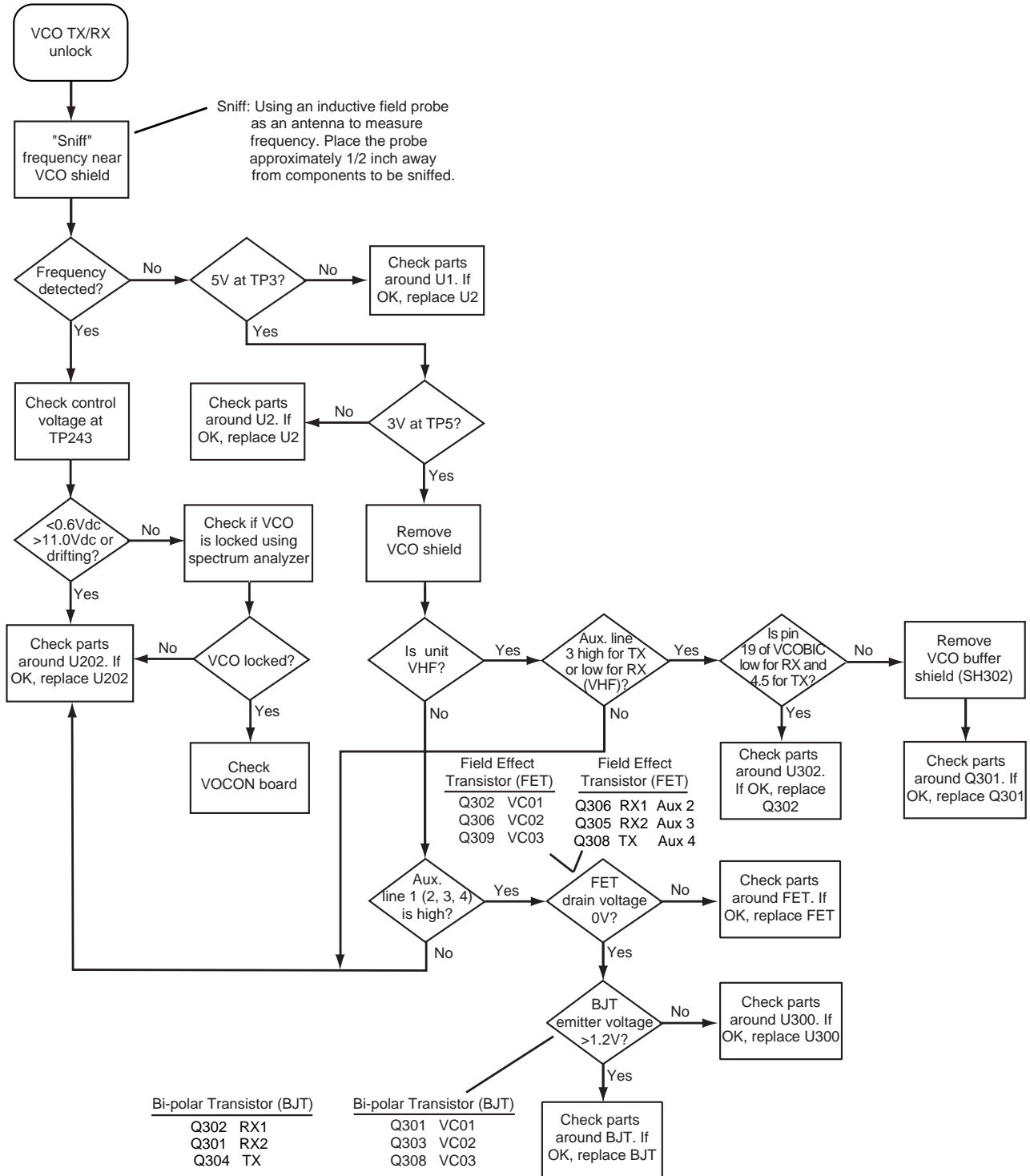

MAEPF-27398-B

## 5.12 VOCON TX Audio—Page 1

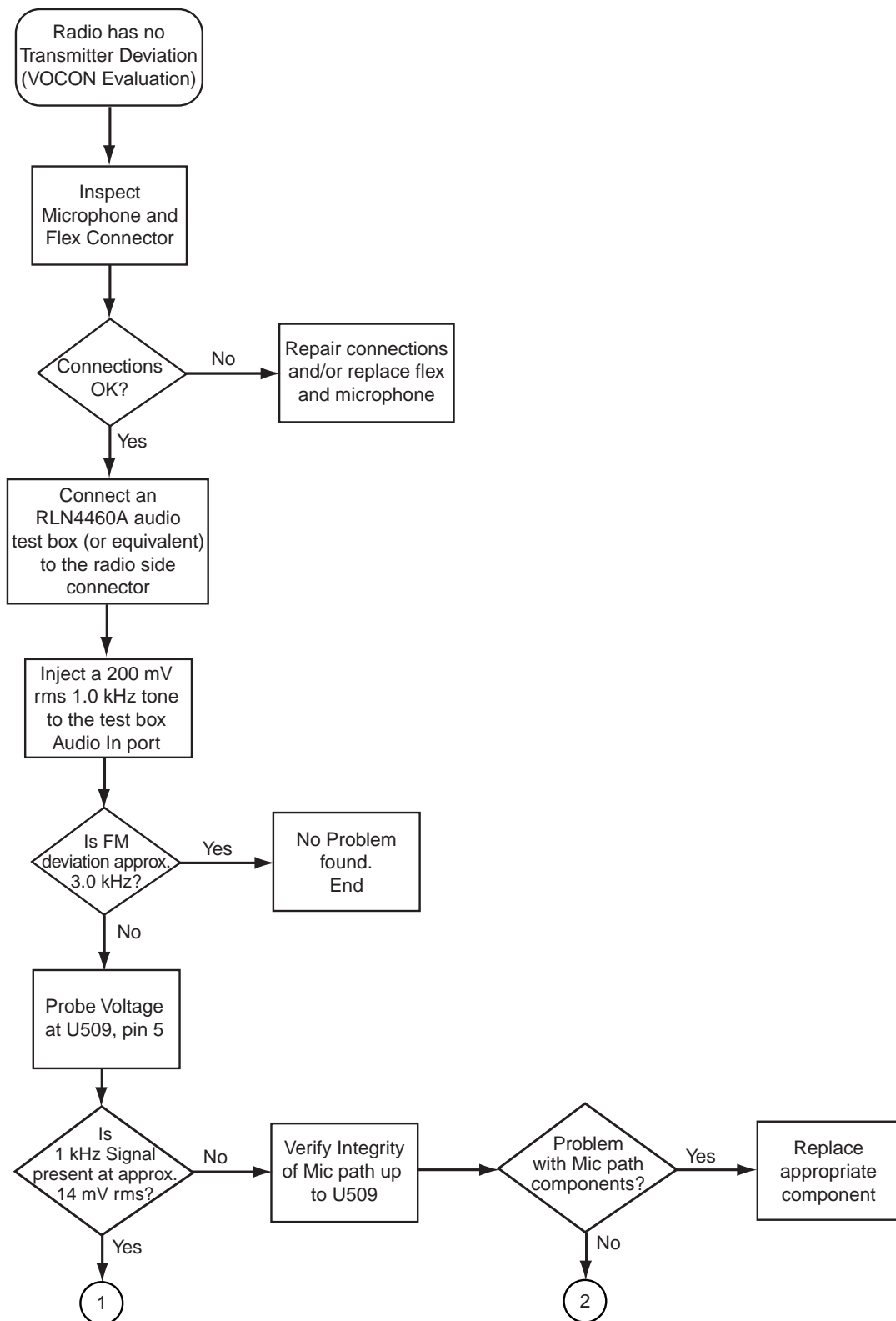

MAEPF-27396-O

VOCON TX Audio—Page 2

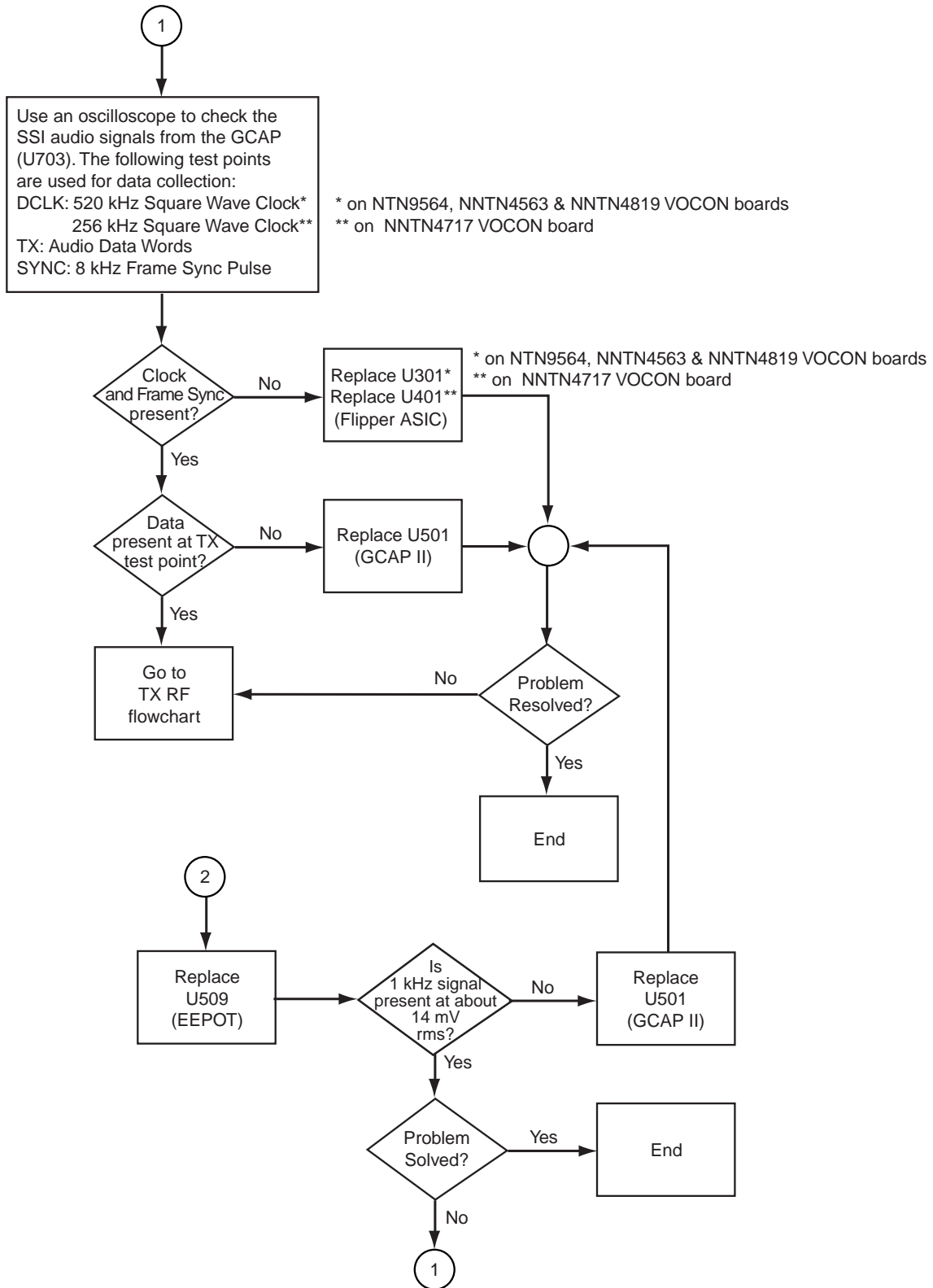

MAEPF-27397-A

### 5.13 VOCON RX Audio—Page 1

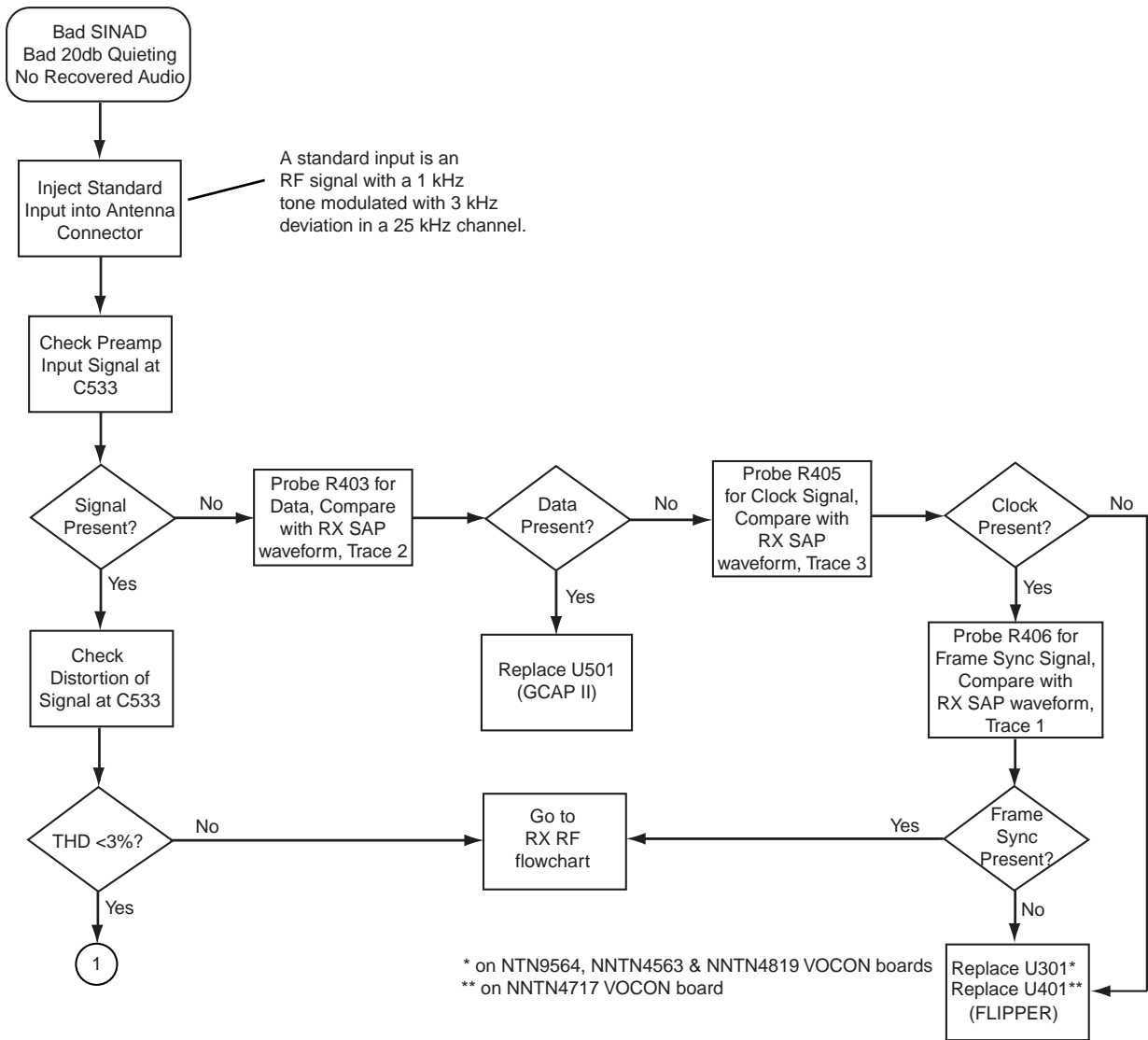

MAEPP-27394-A

## VOCON RX Audio—Page 2

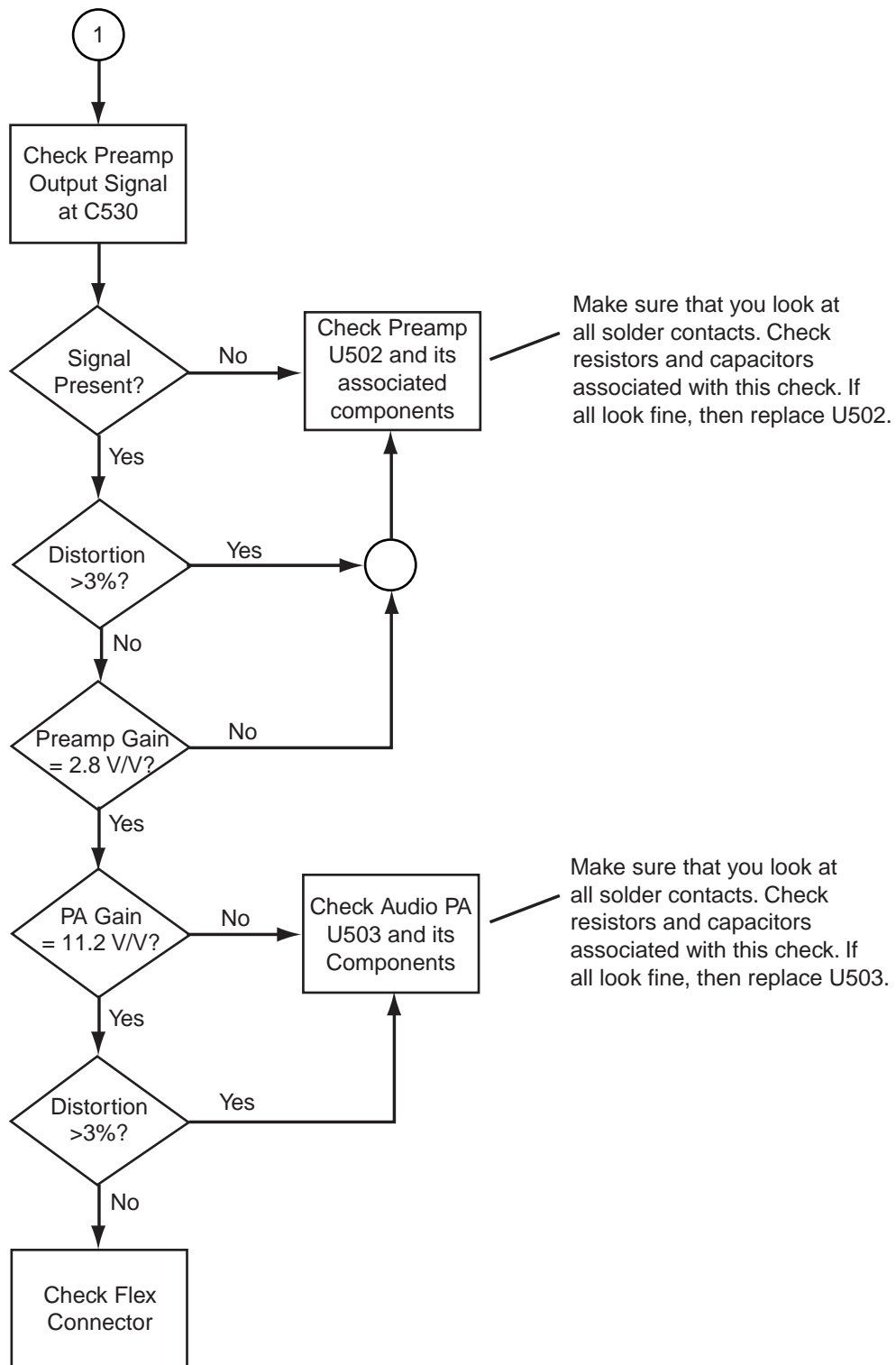

MAEPF-27395-O



### 5.14 RX RF—Page 1

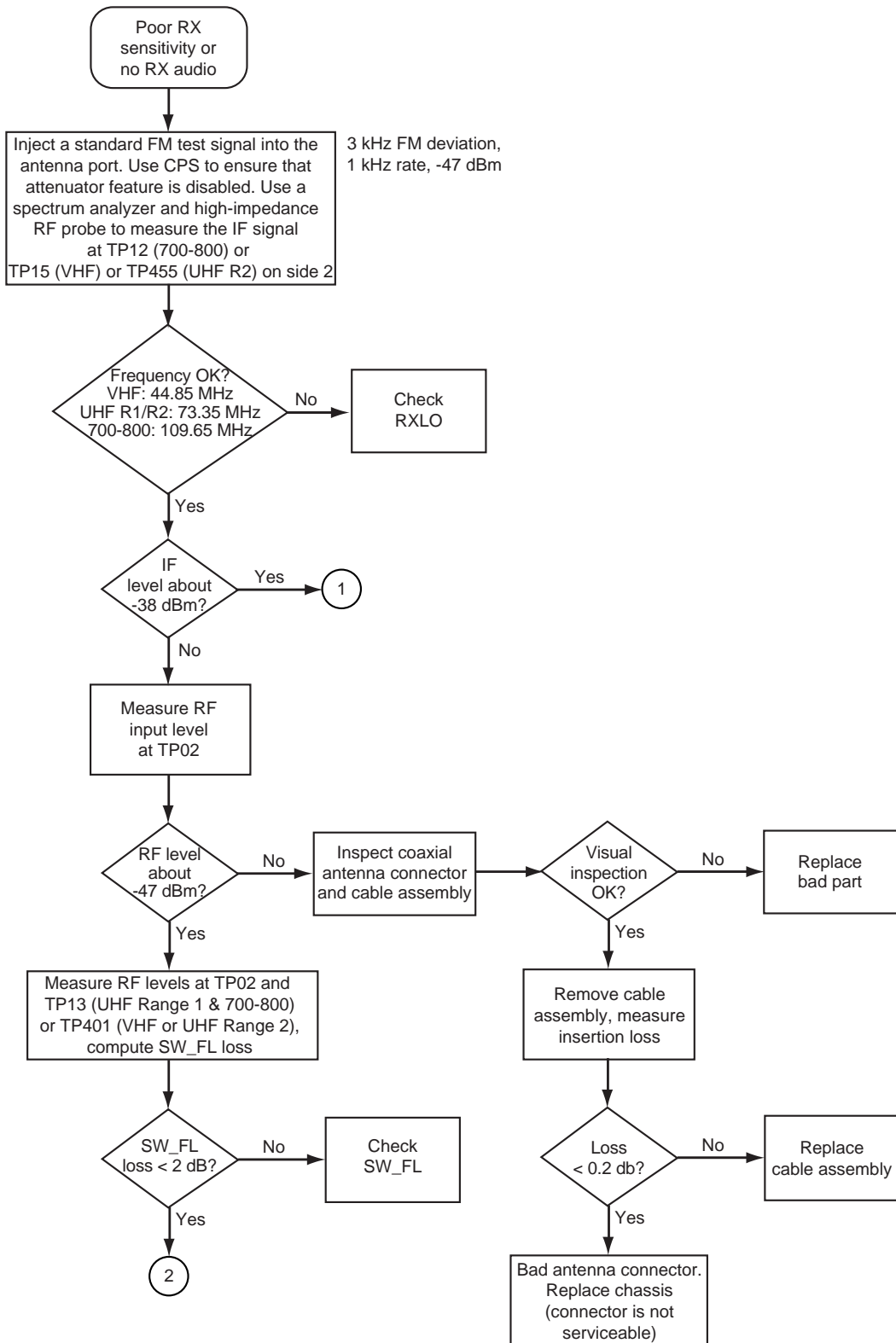

MAEPF-27470-C

RX RF—Page 2

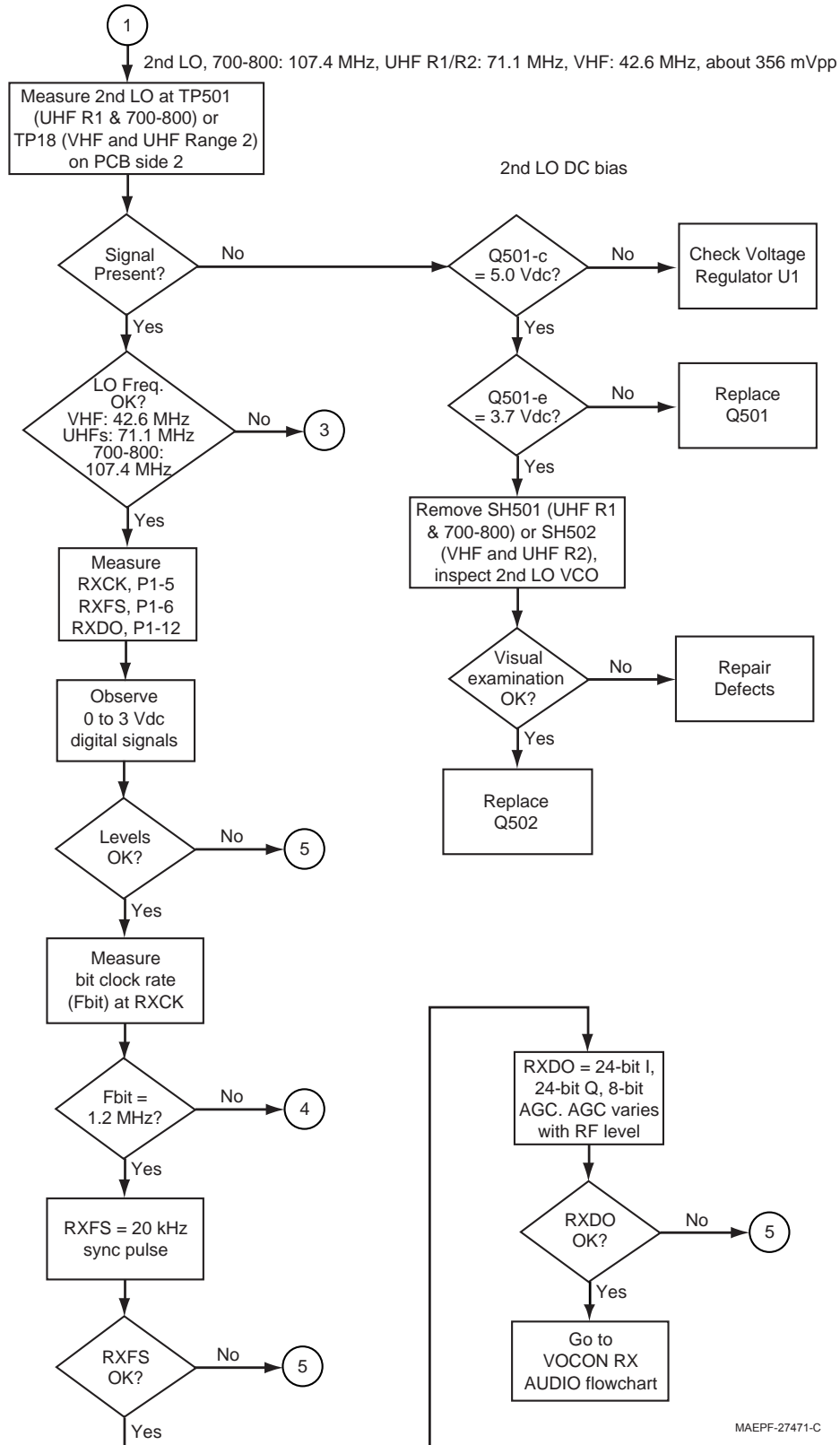

MAEPF-27471-C

RX RF—Page 3

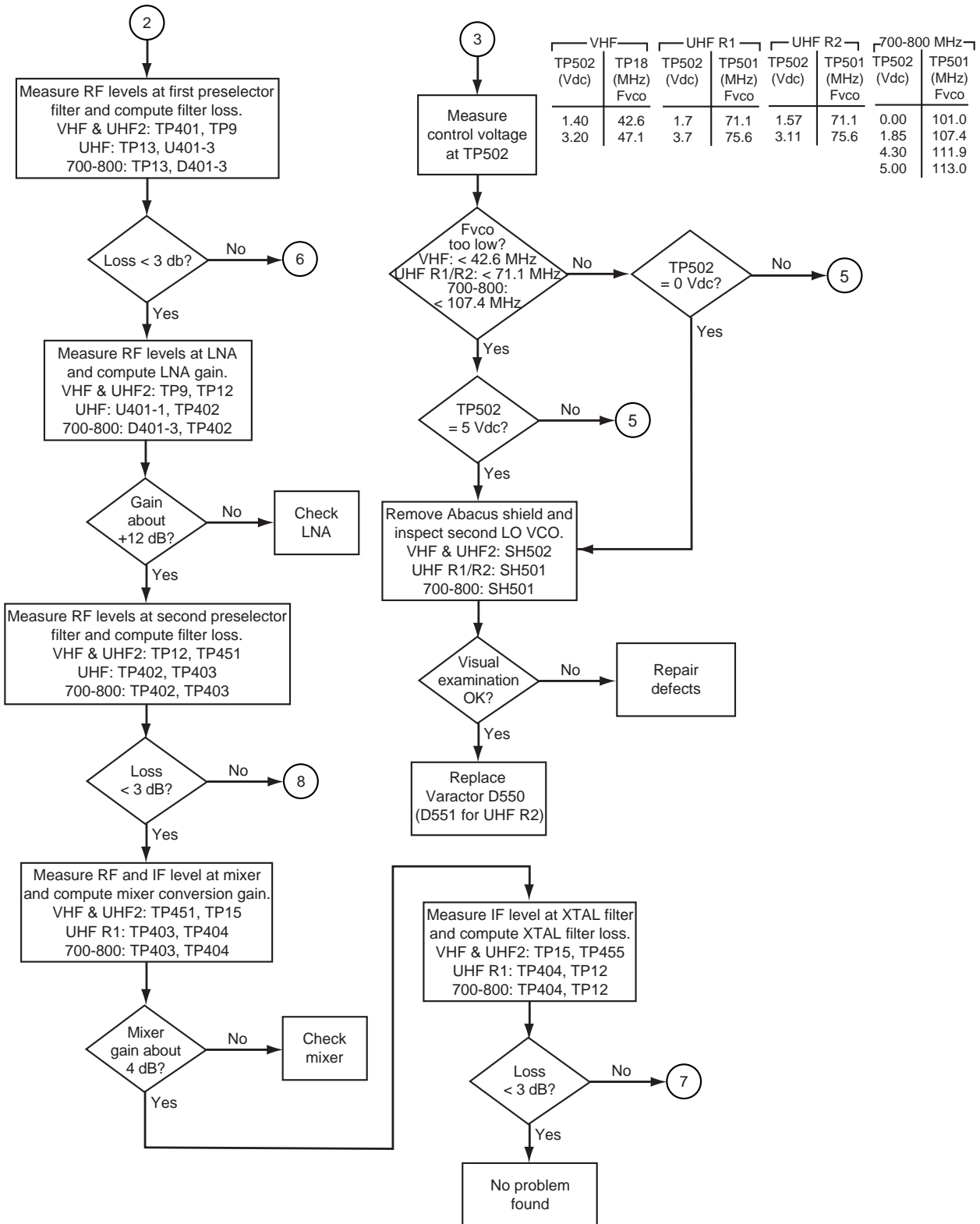

MAEPF-27472-C

# RX RF—Page 4

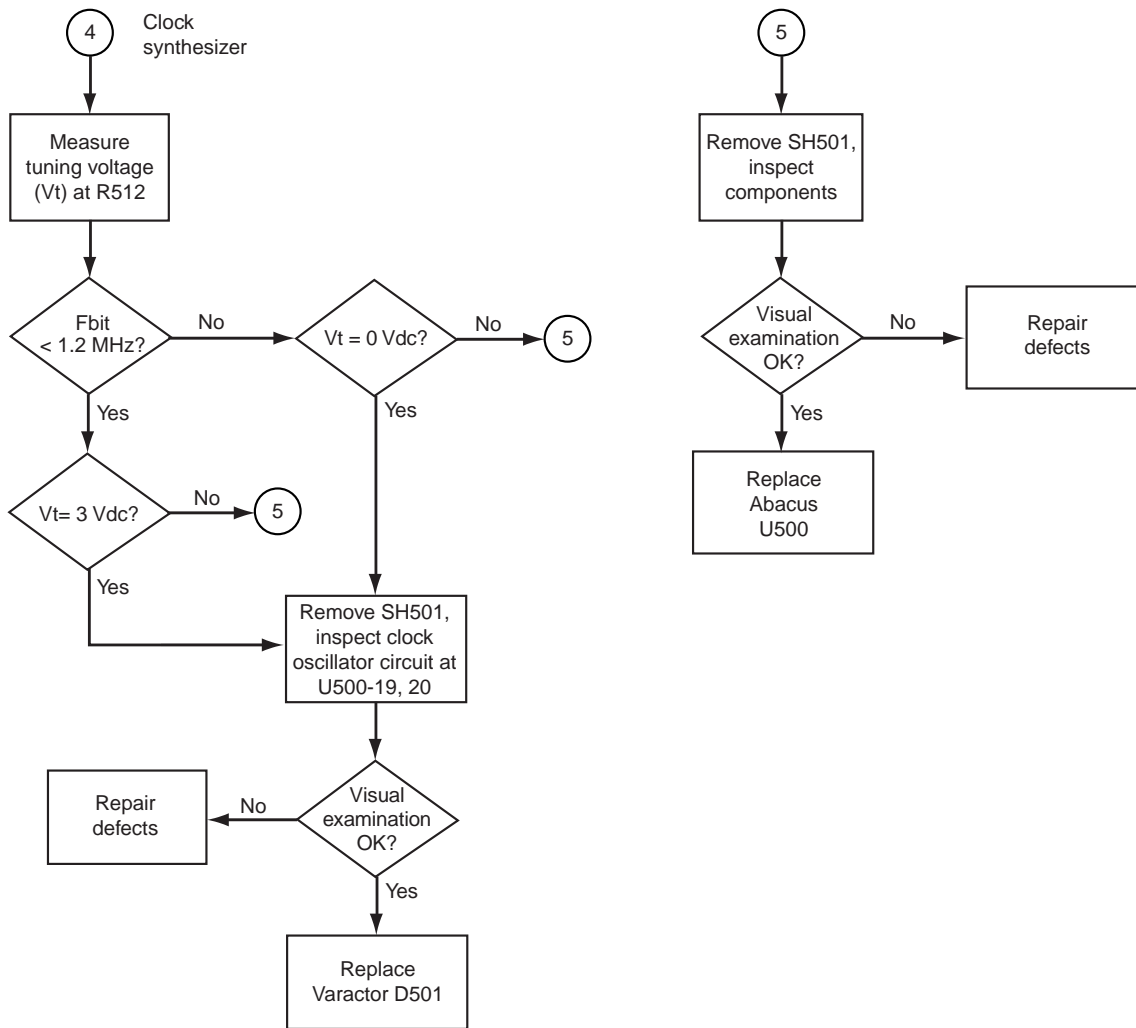

MAEPF-27473-O

**RX RF—Page 5**

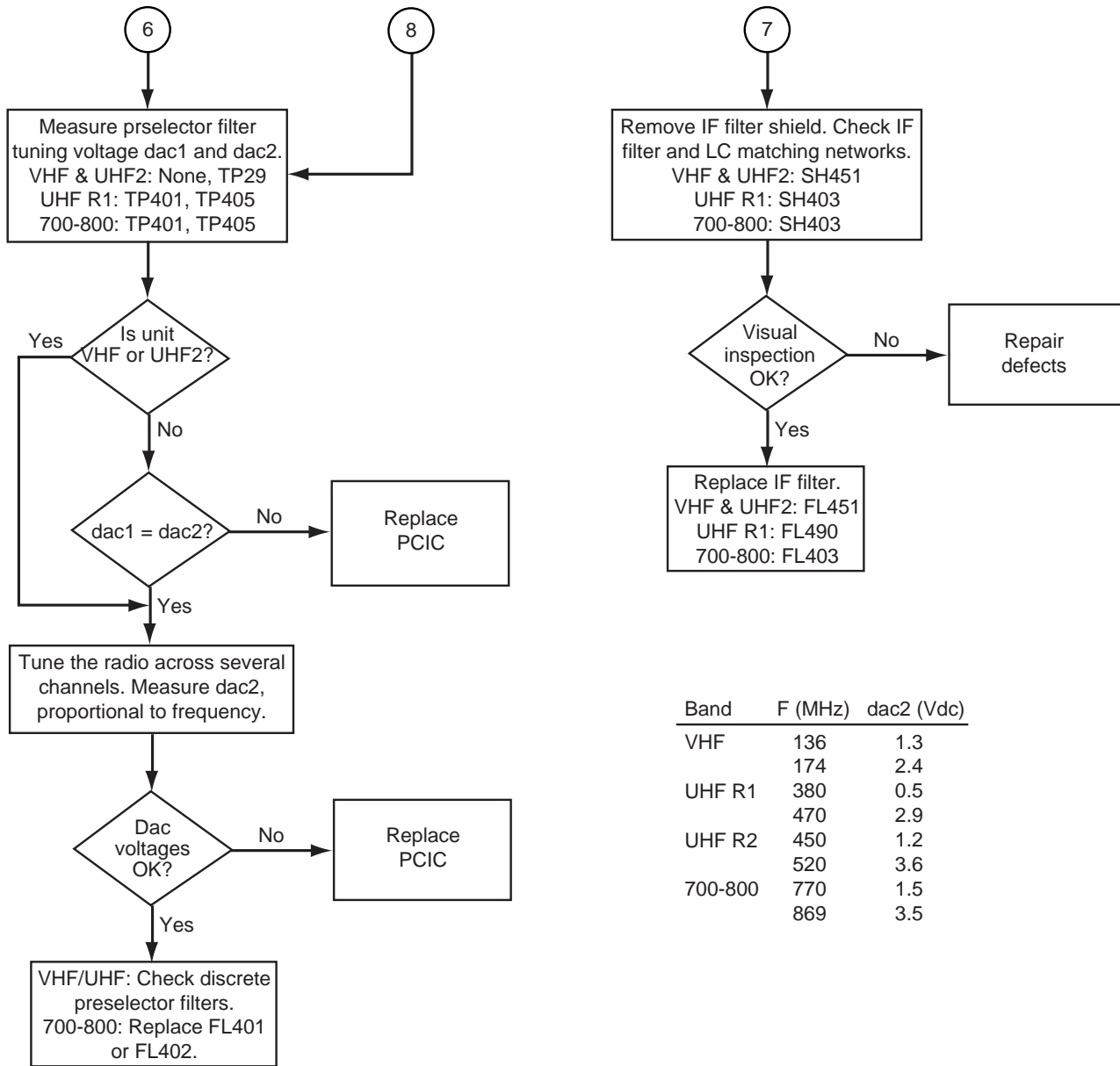

Band	F (MHz)	dac2 (Vdc)
VHF	136	1.3
	174	2.4
UHF R1	380	0.5
	470	2.9
UHF R2	450	1.2
	520	3.6
	770	1.5
700-800	770	1.5
	869	3.5

MAEPF-27474-C

### 5.15 TX RF (VHF and UHF Range 2)—Page 1

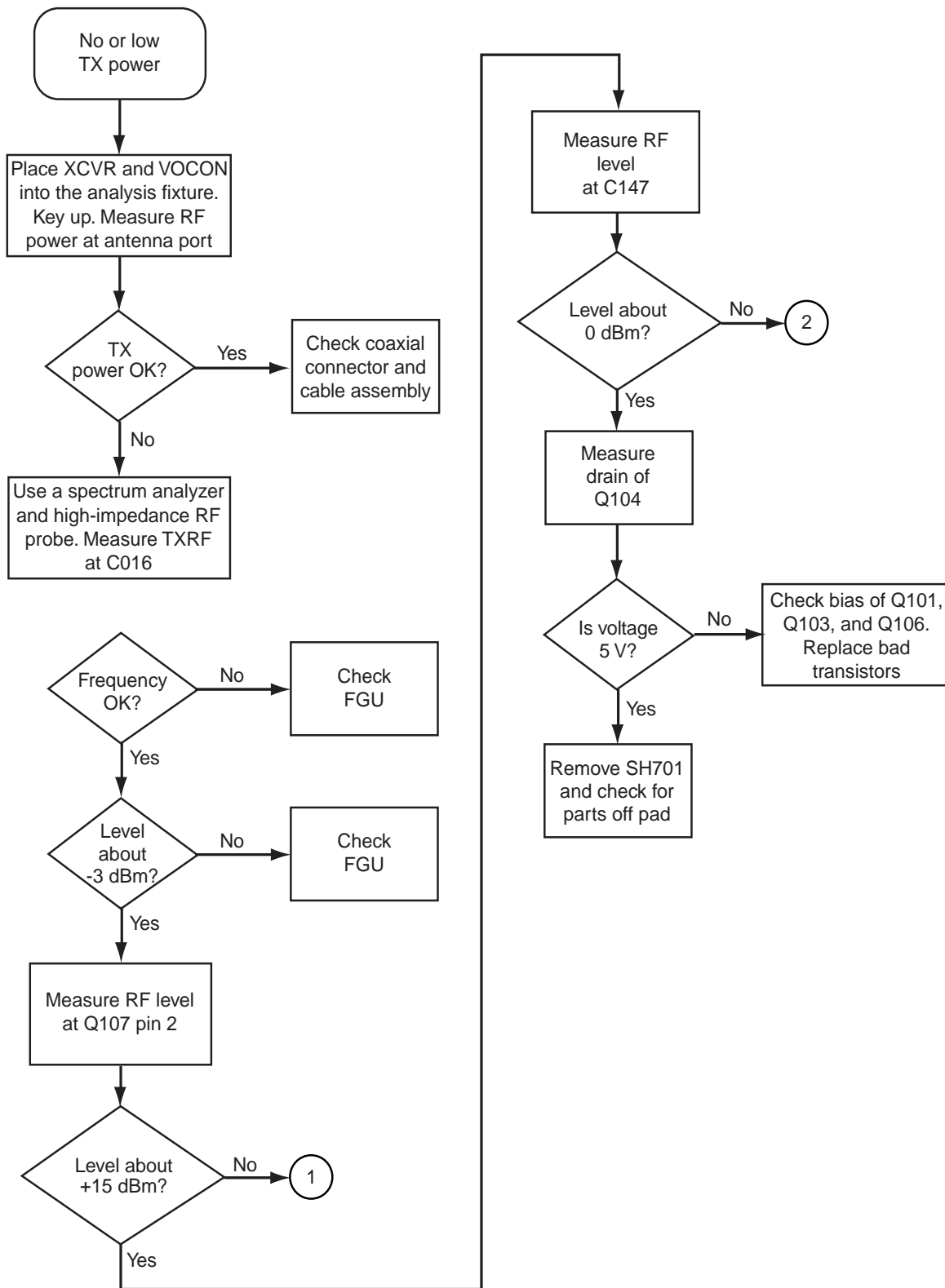

MAEPF-27635-O

## TX RF (VHF and UHF Range 2)—Page 2

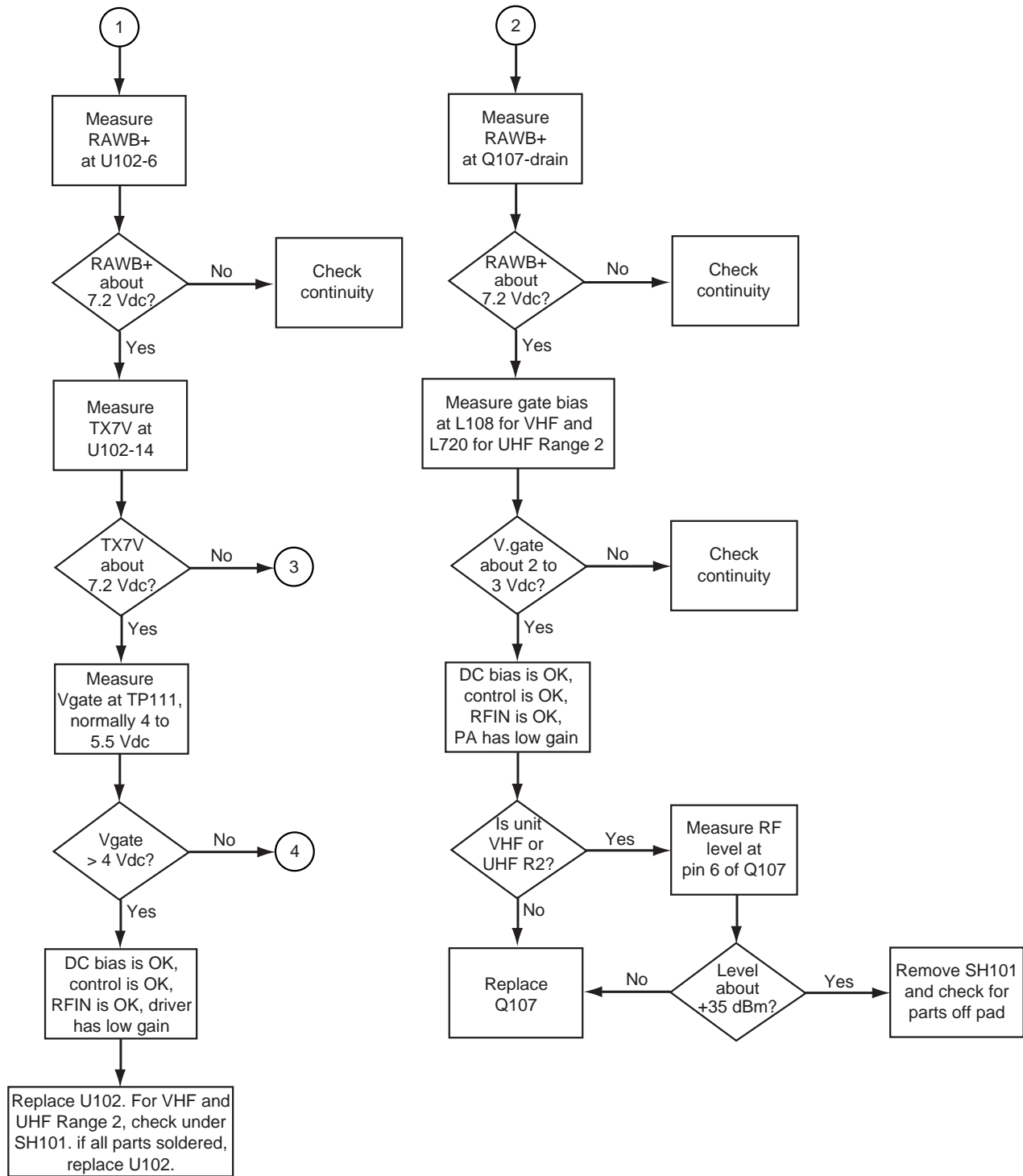

MAEPF-27420-C

**TX RF (VHF and UHF Range 2)—Page 3**

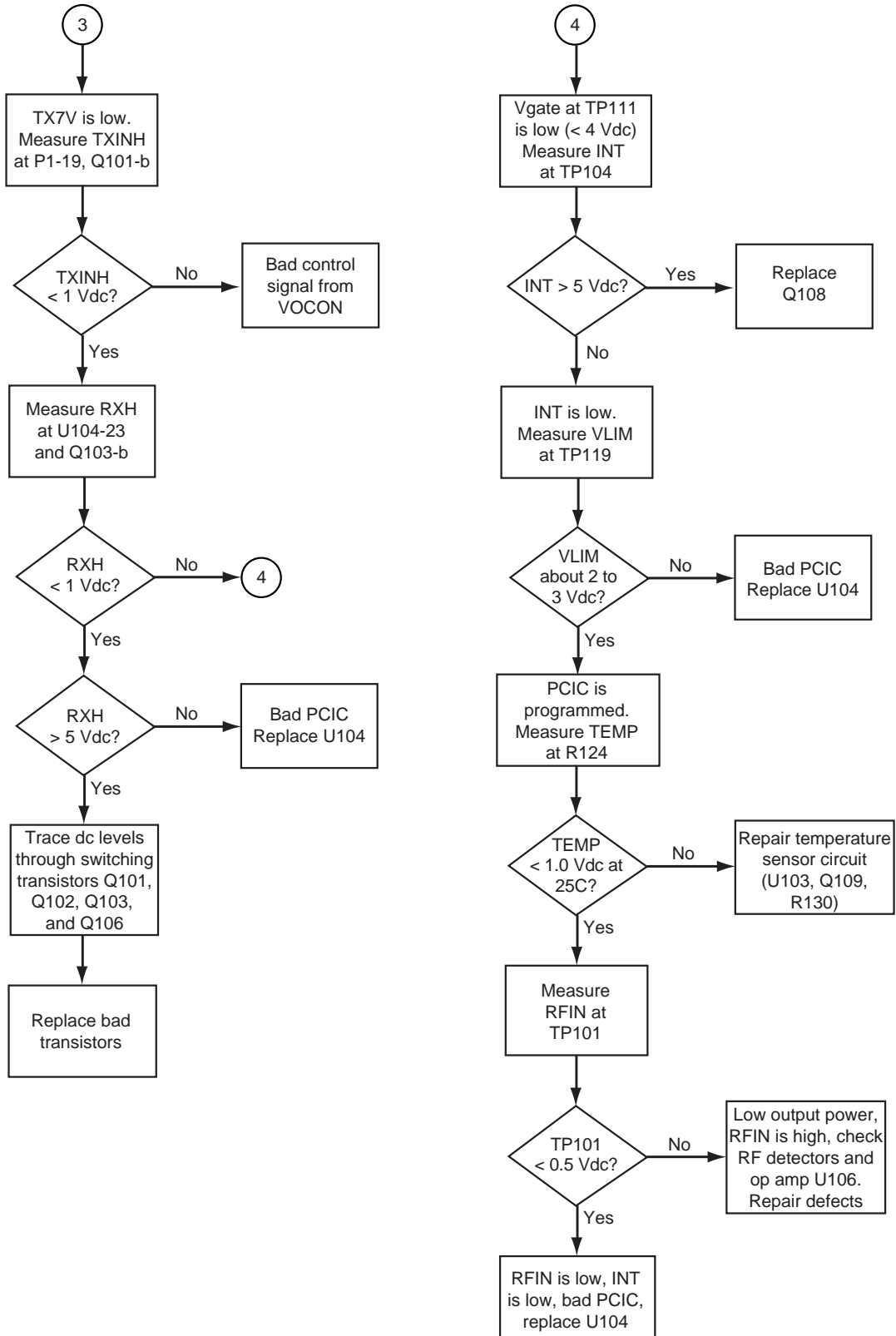

MAEPF-27476-A



### 5.16 TX RF (UHF R1/700-800 MHz)—Page 1

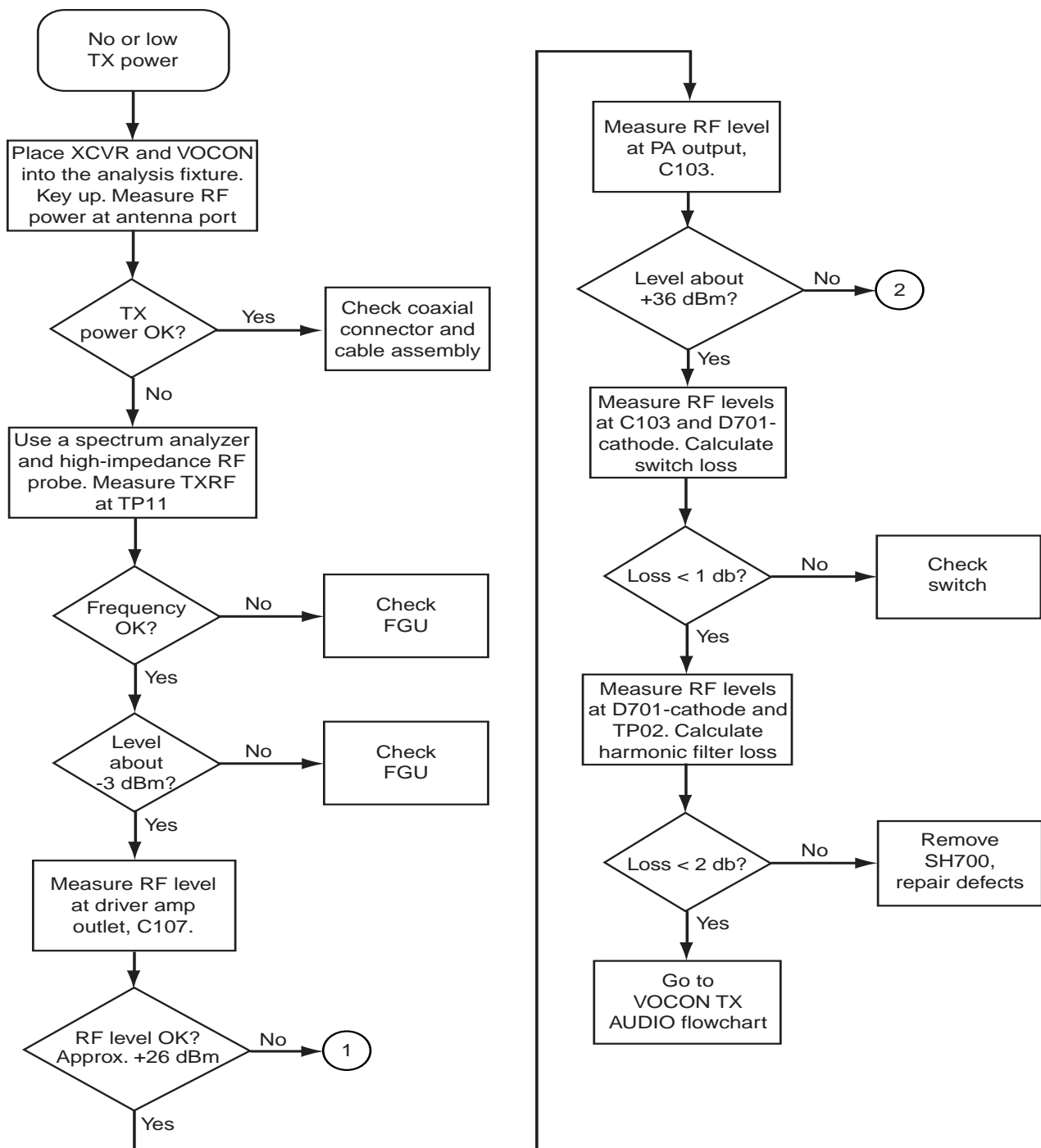

MAEPF-27475-B

**TX RF (UHF R1/700-800 MHz)—Page 2**

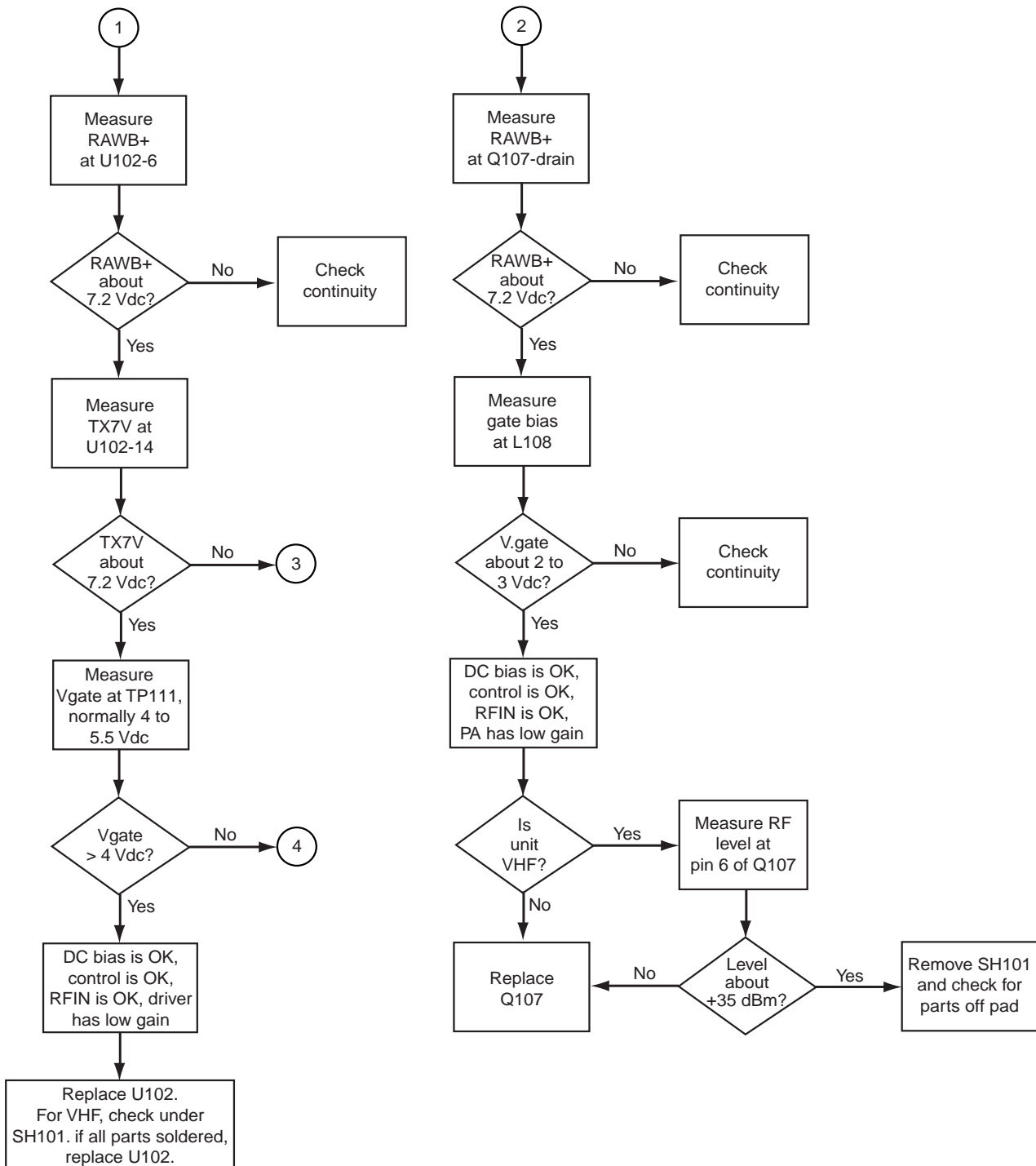

MAEPF-27420-B

**TX RF (UHF R1/700-800 MHz)—Page 3**

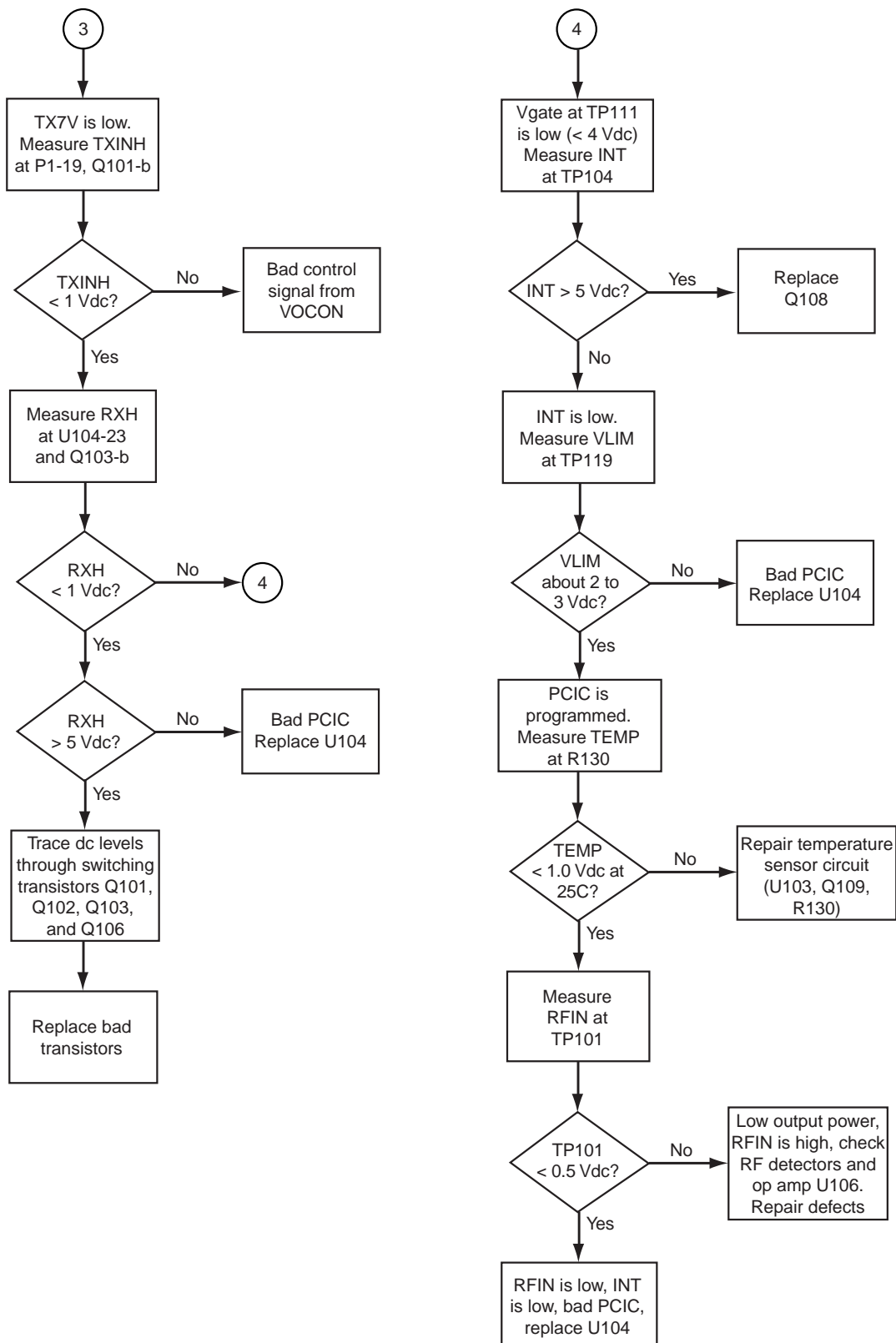

MAEPF-27476-O

## 5.17 Keyload Failure

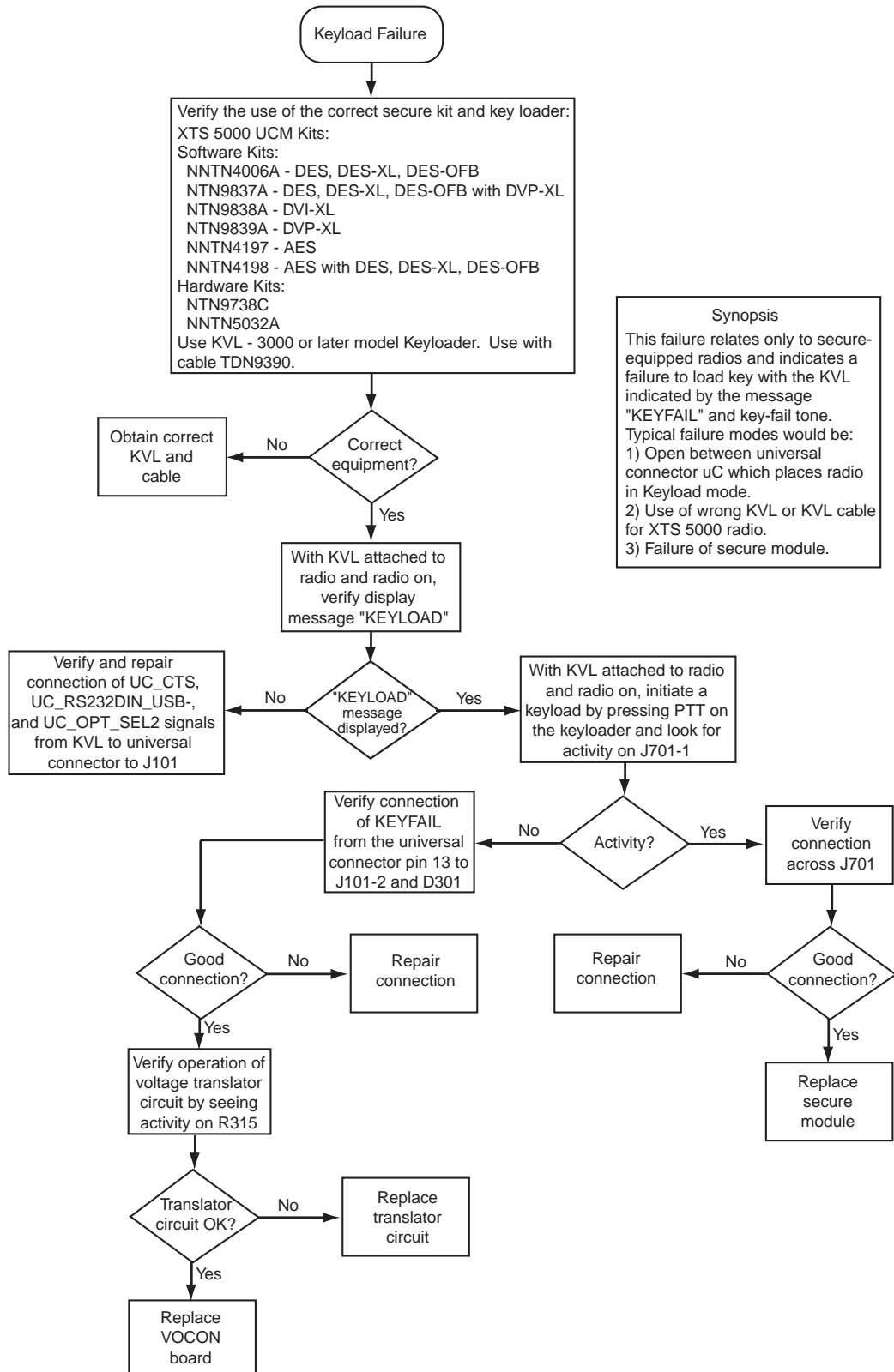

**Synopsis**  
 This failure relates only to secure-equipped radios and indicates a failure to load key with the KVL indicated by the message "KEYFAIL" and key-fail tone. Typical failure modes would be:  
 1) Open between universal connector uC which places radio in Keyload mode.  
 2) Use of wrong KVL or KVL cable for XTS 5000 radio.  
 3) Failure of secure module.

MAEPF-27388-B

## 5.18 Secure Hardware Failure

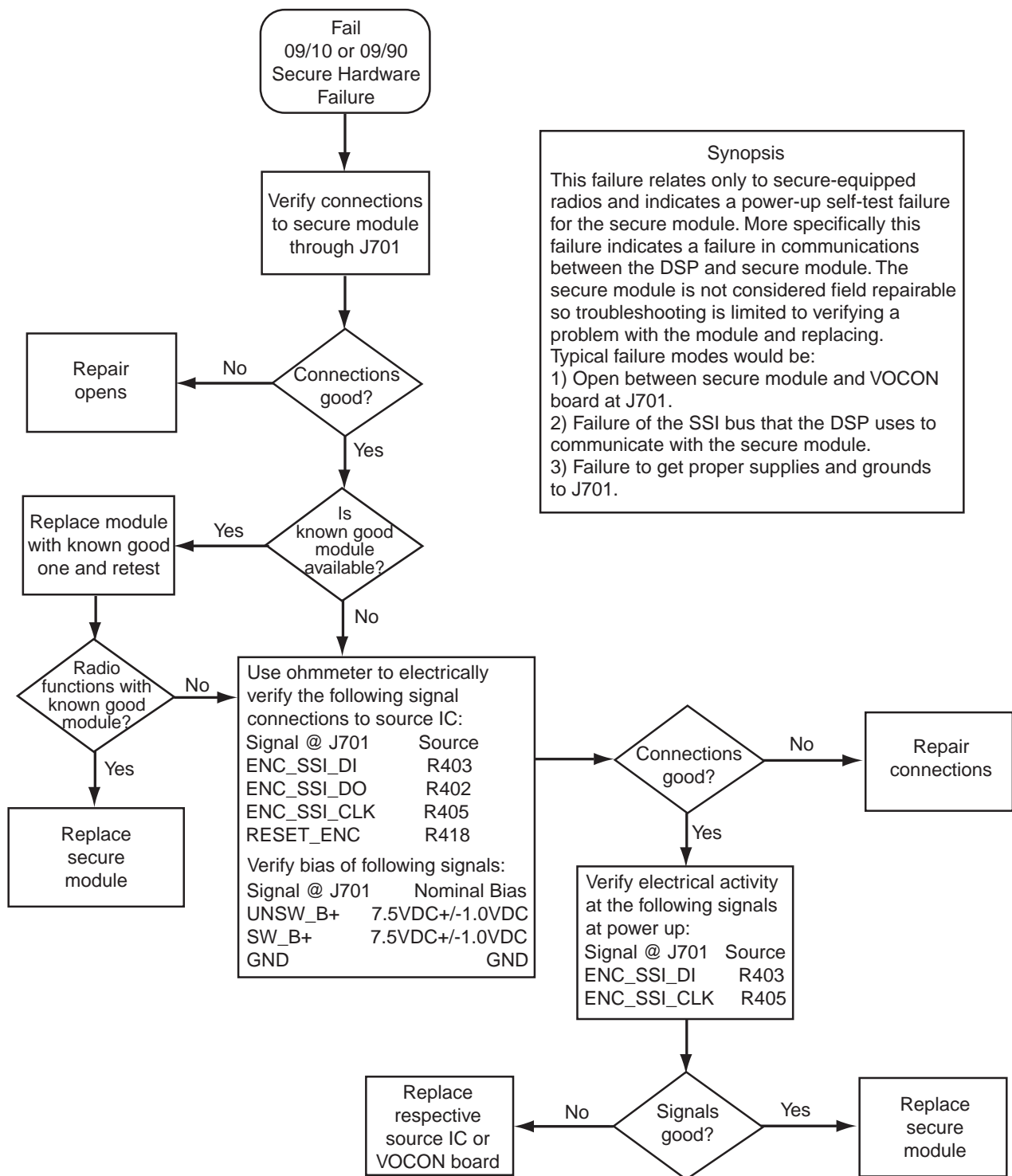

**Synopsis**

This failure relates only to secure-equipped radios and indicates a power-up self-test failure for the secure module. More specifically this failure indicates a failure in communications between the DSP and secure module. The secure module is not considered field repairable so troubleshooting is limited to verifying a problem with the module and replacing. Typical failure modes would be:

- 1) Open between secure module and VOCON board at J701.
- 2) Failure of the SSI bus that the DSP uses to communicate with the secure module.
- 3) Failure to get proper supplies and grounds to J701.

MAEPF-27387-O

## Notes

---

## Chapter 6 Troubleshooting Waveforms

This chapter contains images of waveforms that might be useful in verifying operation of certain parts of the circuitry. These waveforms are for reference only; the actual data depicted will vary depending on operating conditions.

### 6.1 List of Waveforms

[Table 6-1](#) lists each waveform and the page on which the waveform can be found.

*Table 6-1. List of Waveforms*

Waveform	Page No.
<a href="#">13 MHz Clock</a>	6-2
<a href="#">16.8 MHz Buffer Input and Output</a>	6-3
<a href="#">32.768 kHz Clock Outputs</a>	6-4
<a href="#">SPI B Data</a>	6-5
<a href="#">Receive Serial Audio Port (SAP)</a>	6-6
<a href="#">Receive Baseband Interface Port (RX BBP)</a>	6-7
<a href="#">Transmit Baseband Interface Port (TX BBP)</a>	6-8

---

## 6.2 13 MHz Clock

Saved: 04 JAN 2002 10:16:55

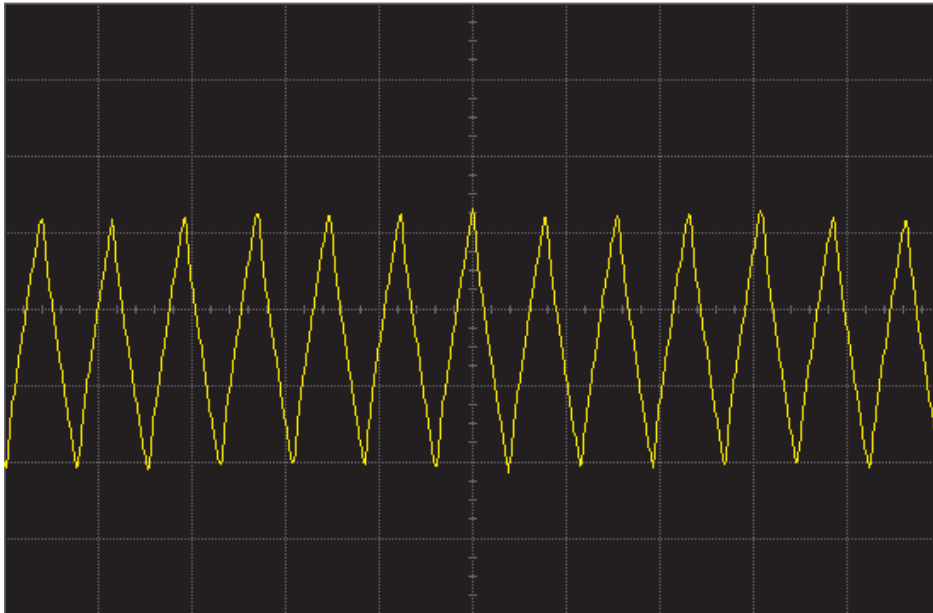

Acquisition    Sampling mode real time Configuration 4GSa/s  
 Memory depth automatic Memory depth 1004pts  
 Sampling rate automatic Sampling rate 1.00 GSa/s  
 Averaging off  
 9-bit B/W Filter off Interpolation on

Channel 1        Scale 200 mV/div Offset 1.604 V Coupling DC Impedance 1M Ohm  
 Attenuation 10.00 : 1 Atten units ratio Skew 0.0 s  
 Ext adapter None Ext coupler None  
 Ext gain 1.00E+00 Ext offset 0.0E+00

Time base        Scale 100 ns/div Position 92.181816  $\mu$ s Reference center

Trigger          Mode edge Sweep auto  
 Hysteresis normal Holdoff time 60 ns Coupling DC  
 Source channel 1 Trigger level 1.379 V Slope rising

MAEPF-27490-O

**13 MHz clock from U301 to U501.**

**Trace 1: Trace recorded at C303 on the NTN9564 board.**

**Similar waveform is visible on C339 on the NNTN4563, NNTN4819, & NNTN4717 VOCON boards.**

*Figure 6-1. 13 MHz Clock Waveform*



### 6.3 16.8 MHz Buffer Input and Output

Saved: 03 JAN 2002 14:53:03

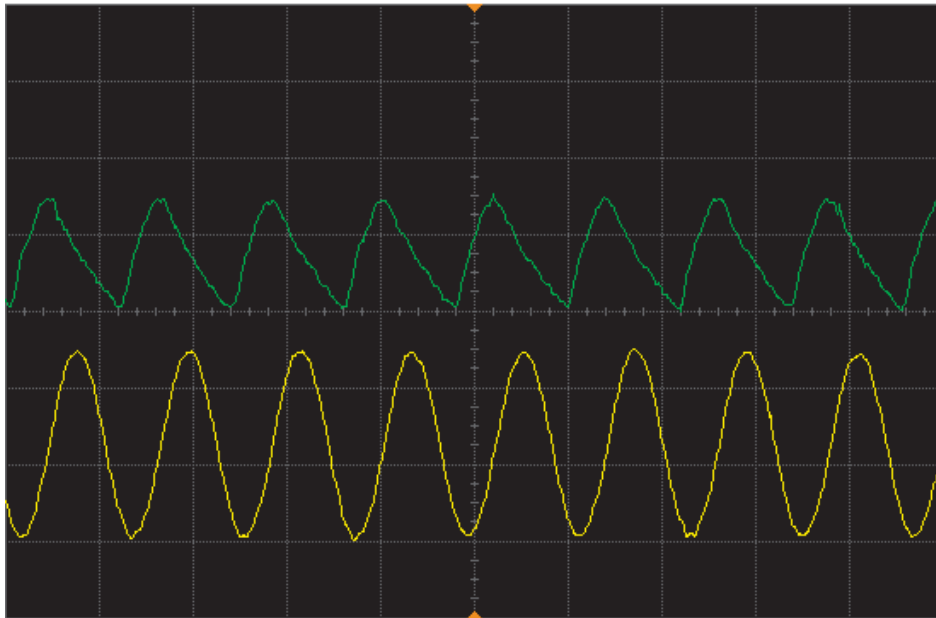

Acquisition      Sampling mode real time Configuration 4GSa/s  
 Memory depth automatic Memory depth 1004pts  
 Sampling rate automatic Sampling rate 2.00 GSa/s  
 Averaging off  
 9-bit BW Filter off Interpolation on

Channel 1        Scale 500 mV/div Offset 1.937 V Coupling DC Impedance 1M Ohm  
 Attenuation 10.00 : 1 Atten units ratio Skew 0.0 s  
 Ext adapter None Ext coupler None  
 Ext gain 1.00E+00 Ext offset 0.0E+00

Channel 2        Scale 500 mV/div Offset -323 mV Coupling DC Impedance 1M Ohm  
 Attenuation 10.00 : 1 Atten units ratio Skew 0.0 s  
 Ext adapter None Ext coupler None  
 Ext gain 1.00E+00 Ext offset 0.0E+00

Time base        Scale 50.0 ns/div Position 0.0 s Reference center

Trigger          Mode edge Sweep auto  
 Hysteresis normal Holdoff time 60 ns Coupling DC  
 Source channel 2 Trigger level 50 mV Slope rising

MAEPF-27491-0

**Trace 1: Buffer input at R452.**

**Trace 2: Buffer output at C452.**

**Note: These components are under shield SH101 on the NNTN4563, NNTN4819, & NNTN4717 VOCON boards.**

*Figure 6-2. 16.8 MHz Buffer Input and Output Waveforms*

## 6.4 32.768 kHz Clock Outputs



Acquisition	Sampling mode real time Configuration 4GSa/s Memory depth automatic Memory depth 1004pts Sampling rate automatic Sampling rate 10.0 MSa/s Averaging off 9-bit BW Filter off Interpolation on
Channel 1	Scale 1.00 V/div Offset -1.58 V Coupling DC Impedance 1M Ohm Attenuation 10.00 : 1 Atten units ratio Skew 0.0 s Ext adapter None Ext coupler None Ext gain 1.00E+00 Ext offset 0.0E+00
Channel 2	Scale 1.00 V/div Offset 2.97 V Coupling DC Impedance 1M Ohm Attenuation 10.00 : 1 Atten units ratio Skew 0.0 s Ext adapter None Ext coupler None Ext gain 1.00E+00 Ext offset 0.0E+00
Time base	Scale 10.0 $\mu$ s/div Position 0.0 s Reference center
Trigger	Mode edge Sweep auto Hysteresis normal Holdoff time 60 ns Coupling DC Source channel 2 Trigger level 1.400 V Slope rising

MAEPF-27492-0

**Trace 1: Output at C313 (to real-time clock of GCAP II IC).**

**Trace 2: Output at U302, pin 2 (to Patriot IC CKIL input).**

**Note: These components are under shield SH102 on the NNTN4563, NNTN4819, & NNTN4717 VOCON boards.**

*Figure 6-3. 32.768 kHz Clock Outputs Waveforms*

## 6.5 SPI B Data

Saved: 03 JAN 2002 15:04:16



Acquisition    Sampling mode real time Configuration 4GSa/s  
 Memory depth automatic Memory depth 1004pts  
 Sampling rate automatic Sampling rate 50.0 MSa/s  
 Averaging off  
 9-bit BW Filter off Interpolation on

Channel 1    Scale 1.99 V/div Offset -4.21 V Coupling DC Impedance 1M Ohm  
 Attenuation 10.00 : 1 Atten units ratio Skew 0.0 s  
 Ext adapter None Ext coupler None  
 Ext gain 1.00E+00 Ext offset 0.0E+00

Channel 2    Scale 2.00 V/div Offset -260 mV Coupling DC Impedance 1M Ohm  
 Attenuation 10.00 : 1 Atten units ratio Skew 0.0 s  
 Ext adapter None Ext coupler None  
 Ext gain 1.00E+00 Ext offset 0.0E+00

Channel 3    Scale 2.00 V/div Offset 5.76 V Coupling DC Impedance 1M Ohm  
 Attenuation 10.00 : 1 Atten units ratio Skew 0.0 s  
 Ext adapter None Ext coupler None  
 Ext gain 1.00E+00 Ext offset 0.0E+00

Time base    Scale 2.00  $\mu$ s/div Position 3.454546  $\mu$ s Reference center

Trigger    Mode edge Sweep auto  
 Hysteresis normal Holdoff time 60 ns Coupling DC  
 Source channel 1 Trigger level 810 mV Slope rising

MAEPF-27493-0

**Trace 1: GCAP II IC chip enable at R539 (Note active high).**  
**Trace 2: SPI data clock at Test Point SCKB.**  
**Trace 3: SPI data to GCAP II IC at Test Point MOSIB.**

*Figure 6-4. SPI B Data Waveforms*

## 6.6 Receive Serial Audio Port (SAP)

Saved: 03 JAN 2002 16:01:58

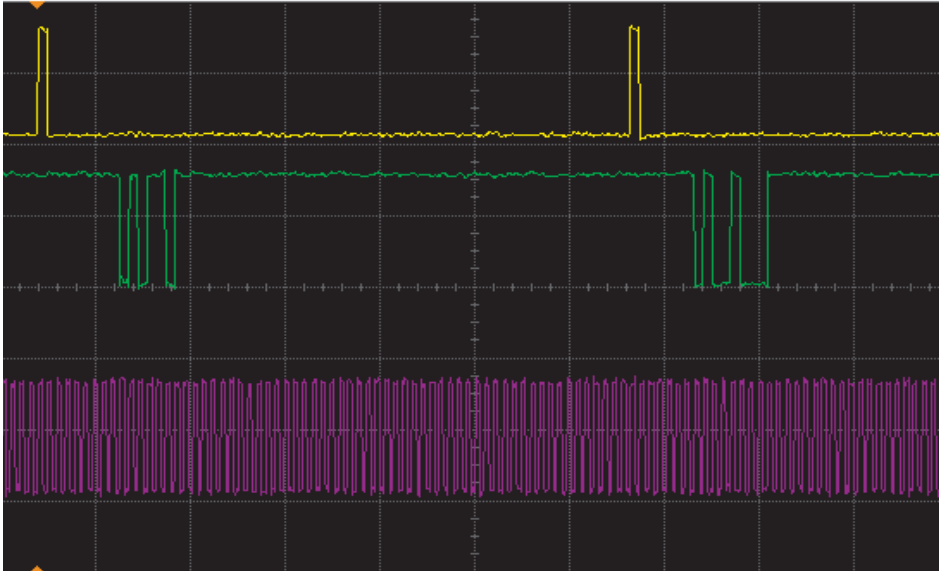

Acquisition	Sampling mode real time Configuration 4GSa/s Memory depth automatic Memory depth 1004pts Sampling rate automatic Sampling rate 5.00 MSa/s Averaging off 9-bit BW Filter off Interpolation on
Channel 1	Scale 1.99 V/div Offset -4.21 V Coupling DC Impedance 1M Ohm Attenuation 10.00 : 1 Atten units ratio Skew 0.0 s Ext adapter None Ext coupler None Ext gain 1.00E+00 Ext offset 0.0E+00
Channel 2	Scale 2.00 V/div Offset -210 mV Coupling DC Impedance 1M Ohm Attenuation 10.00 : 1 Atten units ratio Skew 0.0 s Ext adapter None Ext coupler None Ext gain 1.00E+00 Ext offset 0.0E+00
Channel 3	Scale 2.00 V/div Offset 5.55 V Coupling DC Impedance 1M Ohm Attenuation 10.00 : 1 Atten units ratio Skew 0.0 s Ext adapter None Ext coupler None Ext gain 1.00E+00 Ext offset 0.0E+00
Time base	Scale 20.0 $\mu$ s/div Position 92.181816 $\mu$ s Reference center
Trigger	Mode edge Sweep auto Hysteresis normal Holdoff time 60 ns Coupling DC Source channel 1 Trigger level 810 mV Slope rising

MAEPF-27494-0

**Trace 1: 8 kHz frame sync at R406 (each word is 13 bits after falling edge of FSYNC).**  
**Trace 2: SAP data at R403 (audio data from GCAP II IC CODEC to Patriot IC DSP).**  
**Note: Transmit is identical, except data acquired at R402.**  
**Trace 3: 520 kHz bit clock at R405 on the NTN9564, NNTN4563 & NNTN4819 VOCON boards.**  
**256 kHz bit clock at R405 on the NNTN4717 VOCON board.**

Figure 6-5. Receive Serial Audio Port (SAP) Waveforms

## 6.7 Receive Baseband Interface Port (RX BBP)

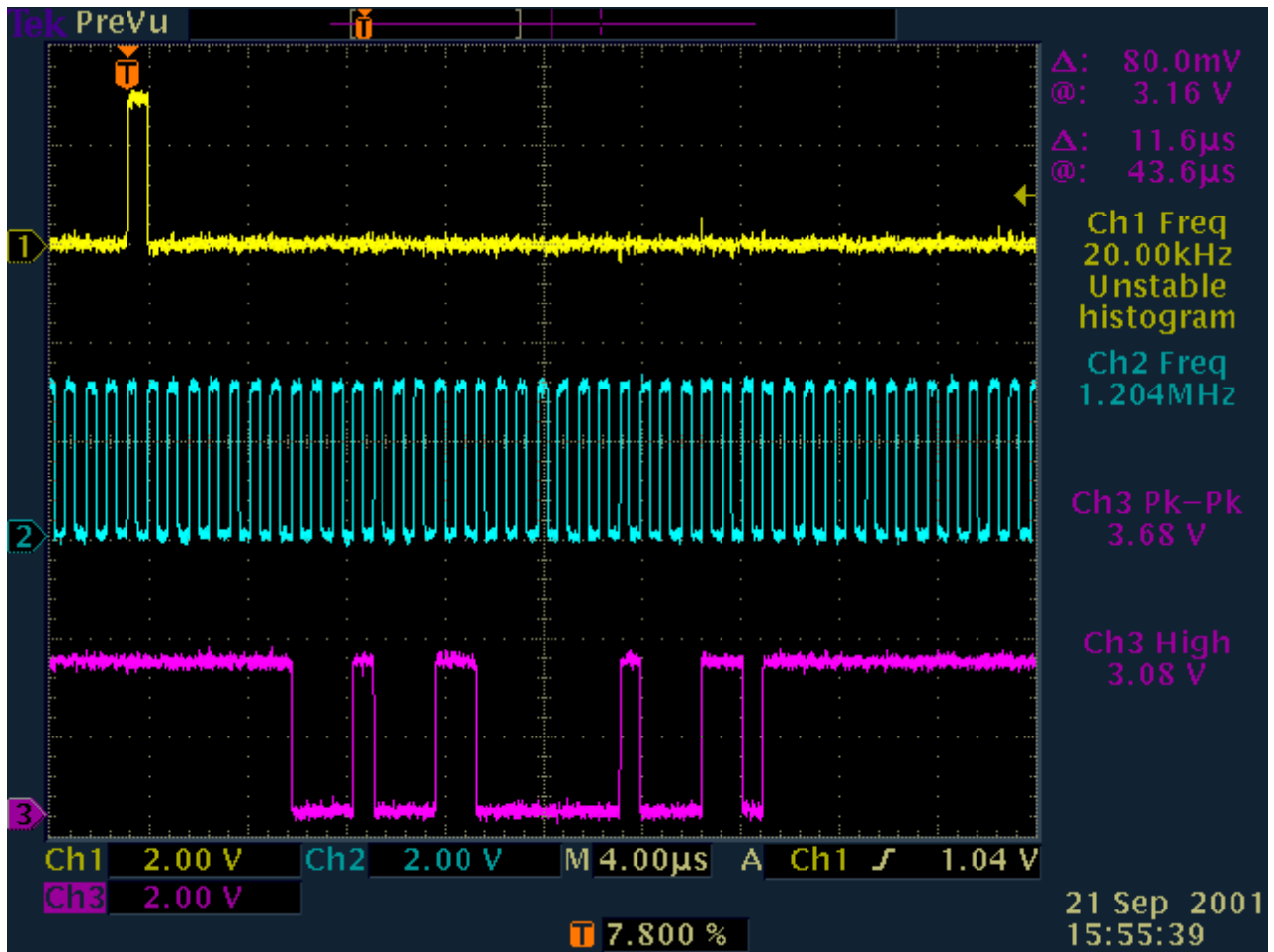

- Trace 1: BBP RX frame sync signal at R123 (P1-6).
- Trace 2: BBP RX clock signal at R124 (P1-5).
- Trace 3: BBP RX data signal at R121 (P1-12).

Figure 6-6. Receive Baseband Interface Port (RX BBP) Waveforms

## 6.8 Transmit Baseband Interface Port (TX BBP)

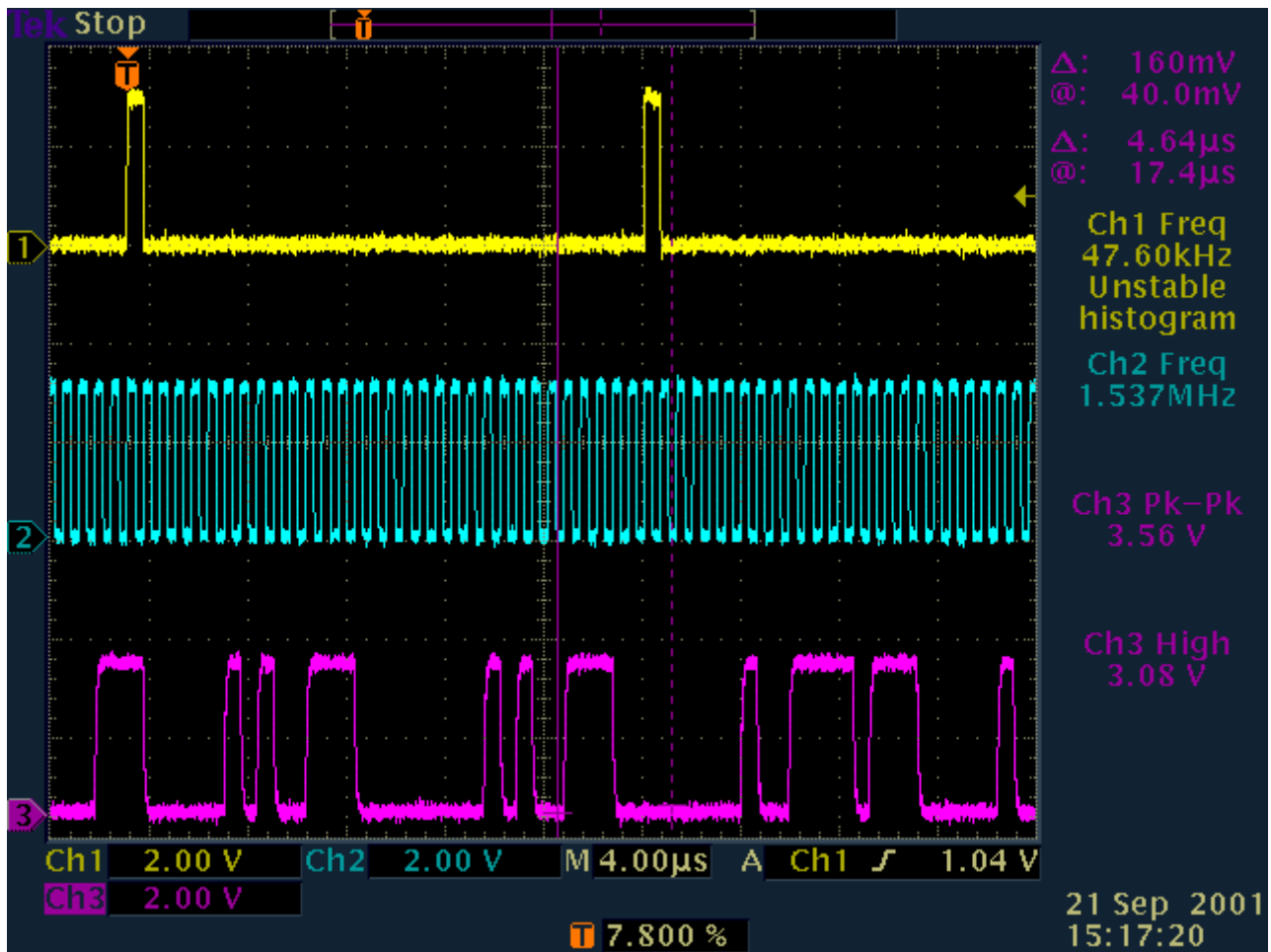

Trace 1: BBP TX frame sync signal at R119.

Trace 2: BBP TX clock signal at R125.

Trace 3: BBP TX data signal at R127.

Figure 6-7. Transmit Baseband Interface Port (TX BBP) Waveforms

---

# Chapter 7 Troubleshooting Tables

## 7.1 List of Board and IC Signals

Due to the nature of the schematic-generating program, signal names might be different when they are not directly connected to the same point. The tables in this chapter provide a cross reference to the various pinouts for these signals. [Table 7-1](#) lists and provides links to each of the tables in this chapter.

*Table 7-1. List of Tables of Board and IC Signals*

Table No.	Table Name	Page No.
<a href="#">7-2</a>	<a href="#">J101 VOCON Board to Controls Flex Assembly</a>	<a href="#">7-1</a>
<a href="#">7-3</a>	<a href="#">J107 VOCON Board to Keypad Module</a>	<a href="#">7-3</a>
<a href="#">7-4</a>	<a href="#">J701 VOCON Board to Encryption Module</a>	<a href="#">7-3</a>
<a href="#">7-5</a>	<a href="#">U402 FLASH Pinouts</a>	<a href="#">7-5</a>
<a href="#">7-6</a>	<a href="#">U403 SRAM Pinouts</a>	<a href="#">7-7</a>
<a href="#">7-7</a>	<a href="#">U401 Patriot MCU/DSP IC Pinouts</a>	<a href="#">7-9</a>
<a href="#">7-8</a>	<a href="#">U301 Flipper IC Pinouts</a>	<a href="#">7-18</a>
<a href="#">7-9</a>	<a href="#">U501 GCAP II IC Pinouts</a>	<a href="#">7-20</a>

*Table 7-2. J101 VOCON Board to Controls Flex Assembly*

J101 Pin No.	Description	To/From	Side Connector Number
1	UC_CTS	TP208	10
2	UC_LHDATA_KEYFAIL	TP206	13
3	DGND03	TP202	8
4	UC_RS232DIN_USB-	R253	12
5	UC_EXT_SPKR_NEG-	TP213	6
6	UC_RS232DOUT_USB+	R252	11
7	UC_OPT_SEL2	R218	5
8	UC_SB9600_BUSY	TP207	9
9	UC_EXT_SKPR	TP212	2
10	UC_RTS	TP209	7

---

Table 7-2. J101 VOCON Board to Controls Flex Assembly (Continued)

J101 Pin No.	Description	To/From	Side Connector Number
11	UC_OPT_SEL1	R217	1
12	UC_OPTB+_VPP	R255	4
13	UC_EXT_MIC	TP214	3
14	UC_EMERG	R233	
15	DGND15	TP202	
16	DGND16	TP202	
17	UC_MONITOR	R244	
18	DGND18	TP202	
19	DGND19	TP202	
20	UC_BL_FREQ	R206	
21	UC_RED_LED	R203	
22	UC_GREEN_LED	R204	
23	UC_TG2	R234	
24	UC_RTA1	R236	
25	UC_RTA3	R241	
26	UC_RTA2	R239	
27	UC_RTA0	R235	
28	DGND28	TP202	
29	DGND29	TP202	
30	DGND30	TP202	
31	UC_VOLUME	R232	
32	BSENS_1	L202	
33	UNSWB+1	L201	
34	UC_TG1	R231	
35	V2A	L203	
36	UC_INT_MICU	L208	
37	C_INT_SPKR_NEG	TP213	
38	UC_INT_PTT	R216	
39	AGND39	L204	
40	UC_INT_SPKR	L205	



Table 7-3. J107 VOCON Board to Keypad Module

J107 Pin No.	Description	To/From	Accessible on VOCON?
1	KP_COLUMN0	C134	Yes
2	KP_COLUMN1	C133	Yes
3	KP_COLUMN2	C132	Yes
4	KP_GND	GROUND	Yes
5	KP_GND	GROUND	Yes
6	KP_BL_EN	C124	Yes
7	KP_5V1	C104	Yes
8	KP_5V2	C104	Yes
9	KP_GND	GROUND	Yes
10	KP_GND	GROUND	Yes
11	KP_GND	GROUND	Yes
12	KP_GND	GROUND	Yes
13	KP_ROW0	C131	Yes
14	KP_ROW1	C130	Yes
15	KP_ROW2	C129	Yes
16	KP_ROW3	C128	Yes
17	KP_ROW4	C127	Yes
18	KP_ROW5	C126	Yes
19	KP_ROW6	C125	Yes
20	KP_GND	GROUND	Yes
21	KP_GND	GROUND	Yes
22	KP_GND	GROUND	Yes

Table 7-4. J701 VOCON Board to Encryption Module

J701 Pin No.	Description	To/From	Accessible on VOCON?
1	KEYFAIL_LH_BDMDATA	Q303 Pin 2	Yes
2	RS232_DIN_ENC	R308	Yes
3	RS232_DIN_UP	R308	Yes
4	RTSIN_ENC	U301 Pin H7	No

Table 7-4. J701 VOCON Board to Encryption Module (Continued)

J701 Pin No.	Description	To/From	Accessible on VOCON?
5	RS232_DOUT_UP	R317	Yes
6	RS232_DOUT_ENC	R317	Yes
7	SW_B+_ENC	C101	Yes
8	Regulated V_ENC	No Connect	N/A
9	RS232_DTR_IN_ENC	No Connect	N/A
10	RS232_RI_OUT_EN	No Connect	N/A
11	USB_MINUS Monitor	No Connect	N/A
12	CONT_3VDC_OUT_ENC	No Connect	N/A
13	RS232_DCD_ENC	No Connect	N/A
14	USB_PLUS Monitor	No Connect	N/A
15	BOOT_ENC	R417	Yes
16	TAMPER	GROUND	Yes
17	SSI_DO_CODEEC_ENC	R403	Yes
18	SSI_DI_CODEEC_ENC	R402	Yes
19	RTA0_ENC	R246	Yes
20	RTA1_ENC	R247	Yes
21	RTA3_ENC	R251	Yes
22	RTA2_ENC	R250	Yes
23	TG2_ENC	R234	Yes
24	LHDATA_BDMDATA_KEYFAIL	D308 Pin 3	Yes
25	GREEN_LED_ENC	R204	Yes
26	WAKEUP	U401 Pin E1	No
27	TX_INHIBIT	R109	Yes
28	UCM_SS	U301 Pin G4	No
29	RED_LED_ENC	R203	Yes
30	RESET_ENC	R418	Yes
31	MONITOR	R244	Yes
32	SPARE1_ENC	R415	Yes
33	GROUND_ENC	GROUND	Yes
34	SPARE2_ENC	R416	Yes
35	EMERG_ENC	R241	Yes

Table 7-4. J701 VOCON Board to Encryption Module (Continued)

J701 Pin No.	Description	To/From	Accessible on VOCON?
36	UNSW_B+_ENC	C102	Yes
37	ENC_SSI_CLK	R404	Yes
38	ENC_SSI_FS	R406	Yes
39	ENC_SSI_DI	R403	Yes
40	ENC_SSI_DOUT	R402	Yes

\* = Component located under a shield on NNTN4563, NNTN4819, & NNTN4717

Table 7-5. U402 FLASH Pinouts

U402 Pin No.	Description	To/From	Comment	Accessible on Vocon?
B4	B_CLK	B_CLK**		Yes
E7	CS0	CS0	Active Low	Yes
F8	EN_OE			No
C5	EN_WE			No
D6	WRITE PROTECT			No
C4	ADV	ADV**		Yes
B5	RESET	D401, pin 2	1.875 V	Yes
E8	ADDRESS 1			No
D8	ADDRESS 2			No
C8	ADDRESS 3			No
B8	ADDRESS 4			No
A8	ADDRESS 5			No
B7	ADDRESS 6			No
A7	ADDRESS 7			No
C7	ADDRESS 8			No
A2	ADDRESS 9			No
B2	ADDRESS 10			No
C2	ADDRESS 11			No
A1	ADDRESS 12			No
B1	ADDRESS 13			No
C1	ADDRESS 14			No

Table 7-5. U402 FLASH Pinouts (Continued)

U402 Pin No.	Description	To/From	Comment	Accessible on Vocon?
D2	ADDRESS 15			No
D1	ADDRESS 16			No
D4	ADDRESS 17			No
B6	ADDRESS 18			No
A6	ADDRESS 19			No
C6	ADDRESS 20			No
B3	ADDRESS 21			No
C3	ADDRESS 22			No
D7	ADDRESS 23	R427*		Yes
A3	GROUND			No
F1	GROUND			No
G2	GROUND			No
G8	GROUND			No
E2	DATA 15			No
F2	DATA 14			No
F3	DATA 13			No
D5	DATA 12			No
F4	DATA 11			No
F5	DATA 10			No
F6	DATA 9			No
G7	DATA 8			No
G1	DATA 7	R435**		Yes
E3	DATA 6	R434**		Yes
G3	DATA 5	R433**		Yes
E4	DATA 4	R432**		Yes
G5	DATA 3	R431**		Yes
E5	DATA 2	R430**		Yes
E6	DATA 1	R429**		Yes
F7	DATA 0	R428**		Yes
A5	VPP	D402, pin 3	1.875 V	Yes
G6	VSW2	C409*	1.875 V	Yes

Table 7-5. U402 FLASH Pinouts (Continued)

U402 Pin No.	Description	To/From	Comment	Accessible on Vocon?
E1	VSW2	C409*	1.875 V	Yes
G4	VSW2	C409*	1.875 V	Yes
A4	VSW2	C409*	1.875 V	Yes

\* = Component located under a shield on NNTN4563, NNTN4819, & NNTN4717

\*\* = No test point/component on NNTN4563, NNTN4819, & NNTN4717 - signal not accessible

Table 7-6. U403 SRAM Pinouts

U403 Pin No.	Description	To/From	Comment	Accessible on Vocon?
A2	EN_OE			No
G5	R_W	R_W	W = 0 V	Yes
A1	LB			No
B2	UB			No
B5	CS1	CS2 (TP)	Active Low	Yes
A6	CS2	C411*	Active Low	Yes
A3	ADDRESS 1			Yes
A4	ADDRESS 2			Yes
A5	ADDRESS 3			Yes
B3	ADDRESS 4			Yes
B4	ADDRESS 5			Yes
C3	ADDRESS 6			Yes
C4	ADDRESS 7			Yes
D4	ADDRESS 8			No
H2	ADDRESS 9			No
H3	ADDRESS 10			No
H4	ADDRESS 11			No
H5	ADDRESS 12			No
G3	ADDRESS 13			No
G4	ADDRESS 14			No
F3	ADDRESS 15			No
F4	ADDRESS 16			No

Table 7-6. U403 SRAM Pinouts (Continued)

U403 Pin No.	Description	To/From	Comment	Accessible on Vocon?
E4	ADDRESS 17			No
D3	ADDRESS 18			No
H1	ADDRESS 19			No
D1	GROUND			No
E6	GROUND			No
E3	GROUND			No
H6	NOT USED			No
G2	NOT USED			No
G1	DATA 15			No
F1	DATA 14			No
F2	DATA 13			No
E2	DATA 12			No
D2	DATA 11			No
C2	DATA 10			No
C1	DATA 9			No
B1	DATA 8			No
G6	DATA 7	R435**		No
F6	DATA 6	R434**		No
F5	DATA 5	R433**		No
E5	DATA 4	R432**		No
D5	DATA 3	R431**		No
C6	DATA 2	R430**		No
C5	DATA 1	R429**		No
B6	DATA 0	R428**		No
D6	VSW2	C411*	1.875 V	Yes
E1	VSW2	C411*	1.875 V	Yes

\* = Component located under a shield on NNTN4563, NNTN4819, & NNTN4717

\*\* = No test point/component on NNTN4563, NNTN4819, & NNTN4717 - signal not accessible

Table 7-7. U401 Patriot MCU/DSP IC Pinouts

U401 Pin No.	Description	To/From	Comment	Accessible on Vocon?
H10	EEPOT_INC*	C537	Active Low	Yes
J14	EXT_SPKR_SEL	Q505, pin 5		Yes
C14	AUDIO_PA_EN	R575		Yes
B14	HOST_WAKE			No
F6	BATTERY_ID	C556		Yes
E5	MECH_SW_BAR	Q508, pin 3	Active Low	Yes
J6	INT_PTT	R216	Active Low	Yes
J5	GCAP_INT	R538		Yes
J4	OPT_SEL1_IN	U201 pin 1		Yes
J3	UART_INT*			No
C16	8KHZ_INT	R406	8 kHz Pulse	Yes
G11	OPT_SEL2_IN	U202 pin 1		Yes
F1	KP_ROW0	C131		Yes
H4	KP_ROW1	C130		Yes
H6	KP_ROW2	C129		Yes
G2	KP_ROW3	C128		Yes
G11	KP_ROW4	C127		Yes
G7	KP_ROW5	C126		Yes
H7	KP_ROW6	C125		Yes
H1	SPARE1_ENC	J701, pin 32		Yes
D1	KP_COL0	C134		Yes
G5	KP_COL1	C133		Yes
F3	KP_COL2	C132		Yes
G4	ENC_RESET	J701, pin 30		Yes
F2	BOOT*	J701, pin 15		Yes
E1	WAKEUP	J701, pin 26		Yes
H6	SPARE2_ENC	J701, pin 34		Yes
G3	NOT USED			No
E7	NOT USED			No
A8	NOT USED			No
F8	MISOA_SEL	U406, pin 2		Yes

Table 7-7. U401 Patriot MCU/DSP IC Pinouts (Continued)

U401 Pin No.	Description	To/From	Comment	Accessible on Vocon?
E8	NOT USED			No
G8	NOT USED			No
C3	NOT USED			No
D4	LOCK_DET	C123	Active Low	Yes
A2	TG2	R234		Yes
B2	RTA3	R241		Yes
A3	RTA2	R239		Yes
B3	RTA1	R236		Yes
B4	RTA0	R235		Yes
A7	VSW2	E401*	1.875 V	Yes
P3	VSW2	E401*	1.875 V	Yes
P6	VSW2	E401*	1.875 V	Yes
T9	VSW2	E401*	1.875 V	Yes
N10	VSW2	E401*	1.875 V	Yes
R16	VSW2	E401*	1.875 V	Yes
H9	V2	E402*	3.0 V	Yes
G9	V2	E402*	3.0 V	Yes
E15	V2	E402*	3.0 V	Yes
A16	V2	E402*	3.0 V	Yes
K10	V2	E402*	3.0 V	Yes
C12	V2	E402*	3.0 V	Yes
D8	V2	E402*	3.0 V	Yes
B7	V2	E402*	3.0 V	Yes
A4	V2	E402*	3.0 V	Yes
A16	V2	E402*	3.0 V	Yes
H2	V2	E402*	3.0 V	Yes
K3	VSW2	E401*	1.875 V	Yes
R8	VSW2	E401*	1.875 V	Yes
G15	VSW2	E401*	1.875 V	Yes
C10	VSW2	E401*	1.875 V	Yes
K12	URXD1_USB_VMI			No



Table 7-7. U401 Patriot MCU/DSP IC Pinouts (Continued)

U401 Pin No.	Description	To/From	Comment	Accessible on Vocon?
L16	URTS1_XRXD			No
F13	ADTRIG			No
B16	URXD2	U303, pin 4		Yes
D14	BSY_IN_RTS			No
B12	RX_SSI_DATA	R123	Data From Abacus to DSP	Yes
C11	TX_SSI_CLK	R125	1.536 MHz	Yes
B10	RED_LED	Q201, pin 3	Active High	Yes
D10	GREEN_LED	Q201, pin 5	Active High	Yes
B11	TX_SSI_FSYNC	R119	48 kHz	Yes
J10	CODEC_TX	R402	GCAP to DSP Tx Audio Data	Yes
J15	CODEC_DCLK	R405	520 kHz (NTN9564 NNTN4563 NNTN4819) 256 kHz (NNTN4717)	Yes
K16	CODEC_FSYNC	R406	8 kHz Pulse	Yes
D7	SPI_MISOA	MISOA	SPI A Data In	Yes
D3	SPI_MISOB	MISOB	SPI B Data In	Yes
E6	NOT USED			No
F7	NOT USED			No
D6	EEPROM_SEL*	R132	Active Low	Yes
C5	AD_CS*	R133	Active Low	Yes
A9	NOT USED			No
B8	NOT USED			No
B9	NOT USED			No
A10	NOT USED			No
G6	BT_DISABLE			No
D13	NOT USED			No
S15	BT_WAKE			No
F11	RX_SSI_CLK	R124		Yes

Table 7-7. U401 Patriot MCU/DSP IC Pinouts (Continued)

U401 Pin No.	Description	To/From	Comment	Accessible on Vocon?
B15	OPT_SEL2_OUT	R256		Yes
J13	AUDIO_MODE_SEL	R257		Yes
J16	EEPOT_CS_EXT*	U509, pin 1		Yes
J12	EEPOT_U_D*	U509, pin 2		Yes
H11	EEPOT_CS*	U509, pin 10		Yes
A5	GROUND	GROUND		Yes
N6	GROUND	GROUND		Yes
P8	GROUND	GROUND		Yes
P11	GROUND	GROUND		Yes
M11	GROUND	GROUND		Yes
L15	GROUND	GROUND		Yes
H16	GROUND	GROUND		Yes
F14	GROUND	GROUND		Yes
G14	GROUND	GROUND		Yes
E13	GROUND	GROUND		Yes
B13	GROUND	GROUND		Yes
K15	GROUND	GROUND		Yes
D9	GROUND	GROUND		Yes
C8	GROUND	GROUND		Yes
B5	GROUND	GROUND		Yes
C2	GROUND	GROUND		Yes
C1	GROUND	GROUND		Yes
H3	GROUND	GROUND		Yes
K15	GROUND	GROUND		Yes
T8	GROUND	GROUND		Yes
H15	GROUND	GROUND		Yes
C9	GROUND	GROUND		Yes
B6	ABACUS_CS*	R126	Active Low	Yes
E2	UNI_SEL*	R131	Active Low	Yes
D2	FLPR_CS*		Active Low	No
E3	GCAP_CE	R539	Active High	Yes

Table 7-7. U401 Patriot MCU/DSP IC Pinouts (Continued)

U401 Pin No.	Description	To/From	Comment	Accessible on Vocon?
E4	SCKB	SCKB	SPI B Clock	Yes
B1	NOT USED			No
F4	NOT USED			No
F5	SPI_MOSIB	MOSIB	SPI Data Out	Yes
C7	SCKA	SCKA	SPI A Clock	Yes
C6	MOSIA	MOSIA	SPI Data Out	Yes
G10	NOT USED			No
G16	OPT_SEL1_OUT	U201, pin 3		Yes
J11	CODEC_RX	R403	DSP to GCAP Rx Audio Data	Yes
A12	RX_SSI_FSYNC	R123	20 kHz pulse	Yes
A11	RX_SSI_CLK	R124	1.2 MHz	Yes
E9	TX_SSI_DATA	R127	Data From DSP to A/D	Yes
C15	BSY_OUT_CTS*			No
F12	UTXD2	U303, pin 1*		Yes
D15	USB_SUSP			No
E14	DISPLAY_R_W*	D403, pin 3	W = 0 V	Yes
D16	NOT USED			No
G12	UCTS1_USB_SPEED*			No
K11	UTXD1_USB_VPO			No
K14	USB_VMO			No
K13	USB_TX_EN			No
D5	8 KHZ_INT	R406	8 kHz Pulse	Yes
H14	BL_EN	C124		Yes
K4	LV_DETECT	POR	3.0 V	Yes
F9	NOT USED			No
J2	NOT USED			No
A6	16_8_MHZ	C452*	16.8 MHz	Yes

Table 7-7. U401 Patriot MCU/DSP IC Pinouts (Continued)

U401 Pin No.	Description	To/From	Comment	Accessible on Vocon?
J7	FLIP_32K	32 kHz (NTN9564) U302, pin 2* (NNTN4563 NNTN4819 NNTN4717)	32.768 kHz	Yes
G13	NOT USED			No
J11	MOD	MOD	Bootstrap mode > 2.7 V	Yes
A13	NOT USED			No
M6	NOT USED			No
R1	NOT USED			No
N3	NOT USED			No
M5	NOT USED			No
P2	NOT USED			No
P1	NOT USED			No
N1	NOT USED			No
M4	NOT USED			No
M3	NOT USED			No
M2	NOT USED			No
M1	NOT USED			No
L4	NOT USED			No
L3	NOT USED			No
L1	NOT USED			No
L2	NOT USED			No
K2	NOT USED			No
T1	NOT USED			No
R2	NOT USED			No
T2	NOT USED			No
K7	NOT USED			No
N2	NOT USED			No
L5	NOT USED			No
L6	NOT USED			No
C4	NOT USED			No

Table 7-7. U401 Patriot MCU/DSP IC Pinouts (Continued)

U401 Pin No.	Description	To/From	Comment	Accessible on Vocon?
L13	NOT USED			No
D11	ONE_WIRE_EN*		Active Low	No
E16	KVL_USB_DET*		Active Low	No
F15	NOT USED			No
K5	BAT_BUS_EN*	Q507, pin 2	Active Low	Yes
H8	NOT USED			No
F16	RESET	RESET_OUT (NTN9564) D401, Pin 3 (NNTN4563 NNTN4819, NNTN4717)	Reset = 0 V	Yes
K6	USB_VPI			No
H12	BL_FREQ	Q202, pin 5	Active High	Yes
H13	NOT USED			No
E10	DSP_DE	DSP_DE	ONCE/JTAG	Yes
F10	MCU_DE	MCU_DE	ONCE/JTAG	Yes
D12	TCK	TCK	ONCE/JTAG	Yes
C13	TMS	TMS	ONCE/JTAG	Yes
E11	TRST	TRST	ONCE/JTAG	Yes
A14	TDO	TDO	ONCE/JTAG	Yes
E12	TDI	TDI	ONCE/JTAG	Yes
M16	NOT USED			No
L14	NOT USED			No
P15	NOT USED			No
L11	NOT USED			No
M14	NOT USED			No
N16	NOT USED			No
L12	NOT USED			No
M12	CKO	CKO	Disabled	Yes
N15	NOT USED			No
M15	NOT USED			No

Table 7-7. U401 Patriot MCU/DSP IC Pinouts (Continued)

U401 Pin No.	Description	To/From	Comment	Accessible on Vocon?
R12	ADDRESS 0	J101, pin 7	Not accessible on NNTN4563, NNTN4819, & NNTN4717	Yes
T13	ADDRESS 1			No
M10	ADDRESS 2			No
T12	ADDRESS 3			No
P13	ADDRESS 4			No
M9	ADDRESS 5			No
P10	ADDRESS 6			No
P12	ADDRESS 7			No
N9	ADDRESS 8			No
R10	ADDRESS 9			No
P9	ADDRESS 10			No
L10	ADDRESS 11			No
T10	ADDRESS 12			No
R9	ADDRESS 13			No
L9	ADDRESS 14			No
K9	ADDRESS 15			No
J9	ADDRESS 16			No
L8	ADDRESS 17			No
M8	ADDRESS 18			No
N8	ADDRESS 19			No
K8	ADDRESS 20			No
L7	ADDRESS 21			No
T7	ADDRESS 22			No
R7	ADDRESS 23	R427*		Yes
R3	DATA 15			No
T3	DATA 14			No
N4	DATA 13			No
P4	DATA 12			No
R4	DATA 11			No

Table 7-7. U401 Patriot MCU/DSP IC Pinouts (Continued)

U401 Pin No.	Description	To/From	Comment	Accessible on Vocon?
J8	DATA 10			No
T4	DATA 9			No
N5	DATA 8			No
P5	DATA 7	R435**		Yes
R5	DATA 6	R434**		Yes
T5	DATA 5	R433**		Yes
R6	DATA 4	R432**		Yes
T6	DATA 3	R431**		Yes
M7	DATA 2	R430**		Yes
N7	DATA 1	R429**		Yes
P7	DATA 0	R428**		Yes
N11	R_W	R_W		Yes
T11	NOT USED			No
R14	NOT USED			No
N12	CS3*	R106**	Active Low	Yes
T14	CS2	CS2	Active Low	Yes
R11	NOT USED			No
R15	CS0	CS0	Active Low	Yes
P16	OE_EN			No
M13	EB1_N			No
R13	EBO_N			No
N14	NOT USED			No
T16	WAIT	WAIT**		Yes
P14	NOT USED			No
N13	ADV	ADV**		Yes
T15	B_CLK	B_CLK**		Yes

\* = Component located under a shield on NNTN4563, NNTN4819, & NNTN4717

\*\* = No test point/component on NNTN4563, NNTN4819, & NNTN4717 - signal not accessible

Table 7-8. U301 Flipper IC Pinouts

U301 Pin No.	Description	To/From	Comment	Accessible on Vocon?
E7	RXDIN_ENC_3V	R308		Yes
D5	TXDO_BDI_5V	R329*	5 V RS232 Data Out	Yes
C7	RXDIN_5V	R328*	5 V RS232 Data In	Yes
A8	RTS	D303 pin 3	Request to Send (RS232)	Yes
D7	CTS	R303	Clear to Send (RS232)	Yes
H8	CTS_FILLREQ_3V	R306**		Yes
H3	16.8 MHz	C307*	16.8 MHz Clock	Yes
H6	13 MHz	R302 R331*	13 MHz Clock (OUT)	Yes
H5	PLL_LFT	C302*	PLL Loop Filter	Yes
F4	CODEC_DCLK	R405	520 kHz	Yes
E5	CODEC_FSYNC	R406	8 kHz Pulse	Yes
G4	UCM_SS	J701 pin 28		Yes
G2	V2	C304*	3.0 V	Yes
F1	V2	C317*	3.0 V	Yes
F3	VSS3_DC	GROUND		Yes
F2	VSS3_AC	GROUND		Yes
D8	VCC5	C305*	5.0 V	Yes
C8	VSS5	GROUND		Yes
A7	LI_CELL	C312*	3.0-3.3 V	Yes
C6	VSS3_XTL	GROUND		Yes
A4	UART_TX	NC		No
C4	UART_RX	NC		No
G3	ONE_WIRE_UP			No
G7	KVL_USB_DET			No
G1	ONE_WIRE_EN*			No
B5	BSY_IN_RTS			No
C5	BSY_OUT_CTS			No
E4	UCTS1_USB_SPEED*			No
C1	USB_TXENAB			No



Table 7-8. U301 Flipper IC Pinouts (Continued)

U301 Pin No.	Description	To/From	Comment	Accessible on Vocon?
D1	UTXD1_USP_VPO			No
B1	USB_VMO			No
C3	URTS1_XRXD			No
C2	USB_VPI			No
D2	URXD1_USB_VMI			No
E3	USB_SUSP			No
B2	SCKB	SCKB	SPI B Clock	Yes
B3	SPI_MOSIB	MOSIB	SPI Data Write to Flipper IC	Yes
A2	SPI_MISOB	MISOA	SPI Data Read from Flipper IC	Yes
A1	FLPR_CS*			No
A3	UART_INT*			No
F5	GCAP_RESET_X	C310*		Yes
H4	TEST_MODE1	GROUND		Yes
H1	TES_MODE2	GROUND		Yes
G6	OUT_DIS	GROUND		Yes
G5	SCAN_EN	GROUND		Yes
A6	XTAL32_IN			Yes
B6	XTAL32_OUT			Yes
A5	REF32_OUT	R316	32.768 kHz Square Wave	Yes
B7	BYPASS_32	GROUND		Yes
B4	BP_SEN_X	R510	0 V	Yes
D4	WD_OUT	R528	Watchdog Int to GCAP II	Yes
H2	ONE_WIRE_OPT	D306 pin 3		Yes
D6	SB96D_BDO_KF_5V	NC		No
B8	LH_BUSY	D307 pin 3		Yes
D3	USB_DIS	R310*		Yes
E2	USB_DPLUS	Q301 pin 1*	USB Data Plus	Yes
E1	USB_DMINUS	Q301 pin 4*	USB Data Minus	Yes
E8	SB96D_BDO_KF_3V	NC		No
F6	SB96D_BDO_3V	D308 pin 3		Yes

Table 7-8. U301 Flipper IC Pinouts (Continued)

U301 Pin No.	Description	To/From	Comment	Accessible on Vocon?
H7	RTS_FILLSEN_3V	NC		No
G8	CTS_FILLREQ_3V	R309*		Yes
F8	TXDO_BDI_ENC_3V	R317		Yes
F7	TXDO_BDI_UP_3V	R317		Yes
E6	RXDIN_ENC_3V	R308		Yes

\* = Component located under a shield on NNTN4563, NNTN4819, & NNTN4717

\*\* = No test point/component on NNTN4563, NNTN4819, & NNTN4717 - signal not accessible

Table 7-9. U501 GCAP II IC Pinouts

U501 Pin No.	Description	To/From	Comment	Accessible on Vocon?
A2	AD4_BD_ID	R525		Yes
B2	AD3_BDTYPE	R524		Yes
B3	AD2_BAT_STAT	R568		Yes
A3	AD_TG1	R523		Yes
D4	AD0_EMERG	R522		Yes
C4	LV_DETECT	R511	Active Low	Yes
B4	AD_TRIG			No
A4	CONV_BYP	C516		Yes
B5	V3	C550	Unused Voltage Regulator	Yes
A5	VIN3	C515	3.77 V	Yes
D5	VSEN1	GROUND	0 V	Yes
C5	VSIN	C515	3.77 V	Yes
C6	VSIM1	C551	Unused Voltage Regulator	Yes
A6	V1	C552	Unused Voltage Regulator	Yes
B6	VIN1	B503	7.5V	Yes
D6	LI_CELL	C553	3.0-3.3V	Yes
D7	CHARGE	NC		No

Table 7-9. U501 GCAP II IC Pinouts (Continued)

U501 Pin No.	Description	To/From	Comment	Accessible on Vocon?
A7	XTAL1	G_32K	32.768 kHz Square Wave	Yes
B7	XTAL2			No
A8	PRSC2	C514	3.77V	Yes
B8	LX2	D502	262.144 kHz Square Wave	Yes
A9	PGND1	GROUND		Yes
B9	FB2	R501	1.85V	Yes
C8	ON	R579		Yes
A10	FB1	R502	3.77V	Yes
B10	LX1	D503	262.144 kHz Square Wave	Yes
C9	PWRON	C529	At Battery Voltage Level	Yes
D8	INT_EXT	GROUND		Yes
C10	PSRC1	C531	At Battery Voltage Level	Yes
E7	WDI	R576	3.0V	Yes
D10	MOSPORTB	C529	At Battery Voltage Level	Yes
D9	ISENSE	NC		No
E8	CHRGC	NC		No
E9	SQ_OUT	NC		No
E10	BPOS	C529	At Battery Voltage Level	Yes
F7	BATTERY	NC		No
F8	AUX_BAT	NC		No
F9	AUX_FET	NC		No
F10	MAIN_FET	NC		No
E6	PGM2	C529	At Battery Voltage Level	Yes
G8	PGM1	C529	At Battery Voltage Level	Yes
G10	AGND1	GROUND		Yes
G9	REF	C528	3.0V	Yes

Table 7-9. U501 GCAP II IC Pinouts (Continued)

U501 Pin No.	Description	To/From	Comment	Accessible on Vocon?
H9	PA_DRV	NC		No
H10	PA_SENSE	NC		No
G7	PGM0	GROUND		Yes
H8	LS3_RX	NC		No
J10	DGND	GROUND		Yes
K10	LS3TX_PABPOS	GROUND		Yes
K1	MIC_OUT	U509 pin 6	AC Mic Signal	Yes
G4	STANDBY	R557	3.0V	Yes
K2	AUX_OUT	U509 pin 6	AC Mic Signal	Yes
H3	AUX_MIC_NEG	C538	Virtual Ground	Yes
J3	MB_CAP	C535		Yes
H4	EXT_MIC	NC		No
K3	MIC_BIAS	C535		Yes
J4	CD_CAP	C543		Yes
K4	VAG	C544		Yes
J5	V2	R560	3.0V	Yes
K5	VIN2	R502	3.77V	Yes
G5	ON2	NC		No
H5	EXTOUT	C533	AC RX Audio Signal	Yes
K6	SPKR_OUT	NC		No
J6	SPKR_IN	NC		No
H6	SPKR_NEG	NC		No
H7	SPKR_POS	NC		No
K7	LS1IN_TG1A	GROUND		Yes
J7	LS1OUT_TG1	NC		No
G6	LS2IN_TG2A	GROUND		Yes
F6	LS2OUT_TG2			No
K8	ALRT_GND			No
K9	ALRT_OUT	NC		No
J9	ALRT_VCC	NC		No

Table 7-9. U501 GCAP II IC Pinouts (Continued)

U501 Pin No.	Description	To/From	Comment	Accessible on Vocon?
J8	SIMI_O	NC		No
A1	AD5_VOLUME	R526	0-2.5V	Yes
B1	AGND3	GROUND		Yes
C3	DWN_OUT	NC		No
C2	DWN_IN	GROUND		Yes
C1	CMP_OUT	NC		No
D3	DSC_INN	GROUND		Yes
D2	DSC_INP	GROUND		Yes
D1	SPI_CLK	SCKB	SPI Data Clock	Yes
E4	SPI_DR	MISOB	SPI Data Read From GCAP	Yes
E3	SPI_DW	MOSIB	SPI Data Write To GCAP	Yes
E2	SR_VCCIN	NC		No
E1	SR_VCCOUT	NC		No
F3	SR_IN	NC		No
F2	SR_OUT	NC		No
F1	INTERRUPT	R538	GCAP Interrupt	Yes
F4	CE	R539	Active High GCAP Chip EN	Yes
F5	CLK_IN	R302 R331*	13 MHz	Yes
E5	CODEC_DCLK	R405	520 kHz (NTN9564 NNTN4563 NNTN4819) 256 kHz (NNTN4717)	Yes
G1	CODEC_TX	R402	TX Audio Data To DSP	Yes
G2	CODEC_RX	R403	RX Audio Data From DSP	Yes
G3	CODEC_FSYNC	R406	8 kHz Frame Sync	Yes

Table 7-9. U501 GCAP II IC Pinouts (Continued)

U501 Pin No.	Description	To/From	Comment	Accessible on Vocon?
H1	AGND4	GROUND		Yes
J1	AGND2	GROUND		Yes
H2	MICIN_POS	C534		Yes
J2	MICIN_NEG		Virtual Ground	No

\* = Component located under a shield on NNTN4563, NNTN4819, & NNTN4717

## Chapter 8 Schematics, Board Overlays, and Parts Lists

This chapter contains the schematics, board overlays, and parts lists for the XTS 5000 radio. Use them in conjunction with the theory of operation and the troubleshooting procedures, charts, and waveforms to isolate a problem to the component level.

When schematics are viewed on line or as a PDF file, colors can be seen that denote power and signal paths. The red color denotes voltage paths, blue denotes the receive path, and green denotes the transmit path.

The following tables list the pages where the schematics and board overlays for the XTS 5000 radio are found.

### 8.1 List of Transceiver Schematics and Board Overlays

Table 8-1. List of Transceiver Schematics and Board Overlays

Transceiver Board Schematic/Board Layout	Page No.
<b>700–800 MHz</b>	
NUF3577 Transceiver (RF) Board Overall Circuit Schematic	8-3
NUF3577 Antenna Switch and Harmonic Filter Circuits	8-4
NUF3577 Receiver Front End Circuit	8-5
NUF3577 Receiver Back End Circuit	8-6
NUF3577 Transmitter and Automatic Level Control Circuits	8-7
NUF3577 Frequency Generation Unit (Synthesizer) Circuit	8-8
NUF3577 Frequency Generation Unit (VCO) Circuit	8-9
NUF3577 Transceiver (RF) Board Layout—Side 1	8-10
NUF3577 Transceiver (RF) Board Layout—Side 2	8-11
NUF3577C Transceiver (RF) Board Overall Circuit Schematic	8-17
NUF3577C Antenna Switch and Harmonic Filter Circuits	8-18
NUF3577C Receiver Front End Circuit	8-19
NUF3577C Receiver Back End Circuit	8-20
NUF3577C Transmitter and Automatic Level Control Circuits	8-21
NUF3577C Frequency Generation Unit (Synthesizer) Circuit	8-22
NUF3577C Frequency Generation Unit (VCO) Circuit	8-23

Table 8-1. List of Transceiver Schematics and Board Overlays (Continued)

Transceiver Board Schematic/Board Layout	Page No.
NUF3577C Transceiver (RF) Board Layout—Side 1	8-24
NUF3577C Transceiver (RF) Board Layout—Side 2	8-25
<b>VHF</b>	
NLD8910B Transceiver (RF) Board Overall Circuit Schematic	8-31
NLD8910B DC Power Circuits	8-32
NLD8910B Antenna Switch and Harmonic Filter Circuits	8-33
NLD8910B Receiver Front End Circuit	8-34
NLD8910B Receiver Amplifier and Filter Circuit	8-35
NLD8910B Mixer and IF Filter Circuit	8-36
NLD8910B Receiver Back End Circuit	8-37
NLD8910B Transmitter and Automatic Level Control Circuits	8-38
NLD8910B Frequency Generation Unit (Synthesizer) Circuit	8-39
NLD8910B Frequency Generation Unit (VCO) Circuit	8-40
NLD8910B Transceiver (RF) Board Layout—Side 1	8-41
NLD8910B Transceiver (RF) Board Layout—Side 2	8-42
<b>UHF Range 1</b>	
NLE4272A Transceiver (RF) Board Overall Circuit Schematic	8-48
NLE4272A Antenna Switch and Harmonic Filter Circuits	8-49
NLE4272A Receiver Front End Circuit	8-50
NLE4272A Receiver Back End Circuit	8-51
NLE4272A Transmitter Power Amplifier and Automatic Level Control Circuit	8-52
NLE4272A Frequency Generation Unit (Synthesizer) Circuit	8-53
NLE4272A Frequency Generation Unit (VCO) Circuit	8-54
NLE4272A Transceiver (RF) Board Layout—Side 1	8-55
NLE4272A Transceiver (RF) Board Layout—Side 2	8-56
NLE4278A Transceiver (RF) Board Overall Circuit Schematic	8-64
NLE4278A Antenna Switch and Harmonic Filter Circuits	8-65

Table 8-1. List of Transceiver Schematics and Board Overlays (Continued)

Transceiver Board Schematic/Board Layout	Page No.
NLE4278A Receiver Front End Circuit	8-66
NLE4278A Receiver Back End Circuit	8-67
NLE4278A Transmitter Power Amplifier and Automatic Level Control Circuit	8-68
NLE4278A Frequency Generation Unit (Synthesizer) Circuit	8-69
NLE4278A Frequency Generation Unit (VCO) Circuit	8-70
NLE4278A Transceiver (RF) Board Layout—Side 1	8-71
NLE4278A Transceiver (RF) Board Layout—Side 2	8-72

### 8.2 List of VOCON Schematics and Board Overlays

Table 8-2. List of VOCON Schematics and Board Overlays

VOCON Board Schematic/Board Layout	Page No.
NTN9564B VOCON Board Overall Schematic	8-96
NTN9564B VOCON Universal Connector Circuit	8-98
NTN9564B VOCON Flipper Circuit	8-99
NTN9564B VOCON Controller and Memory Circuits	8-100
NTN9564B VOCON Audio and DC Circuits	8-102
NTN9564B VOCON Board Layout—Side 1	8-103
NTN9564B VOCON Board Layout—Side 2	8-104
NTN9564C VOCON Board Overall Schematic	8-110
NTN9564C VOCON Universal Connector Circuit	8-112
NTN9564C VOCON Flipper Circuit	8-113
NTN9564C VOCON Controller and Memory Circuits	8-114
NTN9564C VOCON Audio and DC Circuits	8-116
NTN9564C VOCON Board Layout—Side 1	8-117
NTN9564C VOCON Board Layout—Side 2	8-118

Table 8-2. List of VOCON Schematics and Board Overlays (Continued)

VOCON Board Schematic/Board Layout	Page No.
NNTN4563A/B VOCON Board Overall Schematic	8-124
NNTN4563A/B VOCON Universal Connector Circuit	8-126
NNTN4563A/B VOCON Flipper Circuit	8-127
NNTN4563A/B VOCON Controller and Memory Circuits	8-128
NNTN4563A/B VOCON Audio and DC Circuits	8-130
NNTN4563A/B VOCON Board Layout—Side 1	8-131
NNTN4563A/B VOCON Board Layout—Side 2	8-132
NNTN4819A VOCON Board Overall Schematic—Sheet 1 of 2	8-139
NNTN4819A VOCON Board Overall Schematic—Sheet 2 of 2	8-140
NNTN4819A VOCON Universal Connector and ESD Circuits	8-141
NNTN4819A VOCON Flipper Circuit	8-142
NNTN4819A VOCON Controller and Memory Circuits	8-143
NNTN4819A VOCON Audio/DC Circuits	8-145
NNTN4819A VOCON Board Layout—Side 1	8-146
NNTN4819A VOCON Board Layout—Side 2	8-147
NNTN4717D VOCON Board Overall Schematic—Sheet 1 of 2	8-153
NNTN4717D VOCON Board Overall Schematic—Sheet 2 of 2	8-154
NNTN4717D VOCON Board Universal Connector Circuit Schematic	8-155
NNTN4717D VOCON Board Flipper Circuit	8-156
NNTN4717D VOCON Board Controller and Memory Circuits	8-157
NNTN4717D VOCON Board Audio/DC Circuits	8-159
NNTN4717D VOCON Board Layout—Side 1	8-160
NNTN4717D VOCON Board Layout—Side 2	8-161



### 8.3 Transceiver (RF) Boards

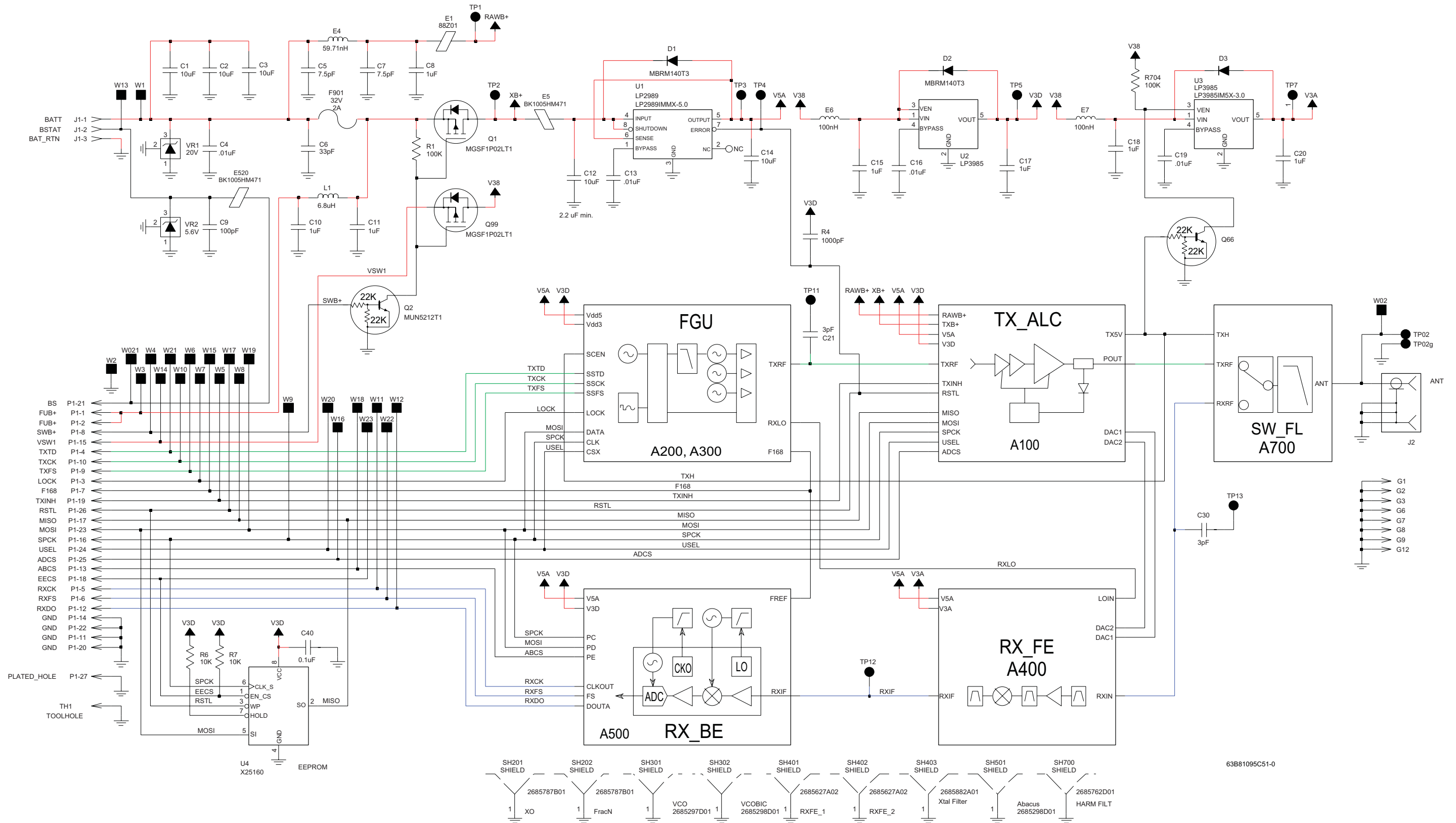

Figure 8-1. NUF3577 700–800 MHz Transceiver (RF) Board Overall Circuit Schematic

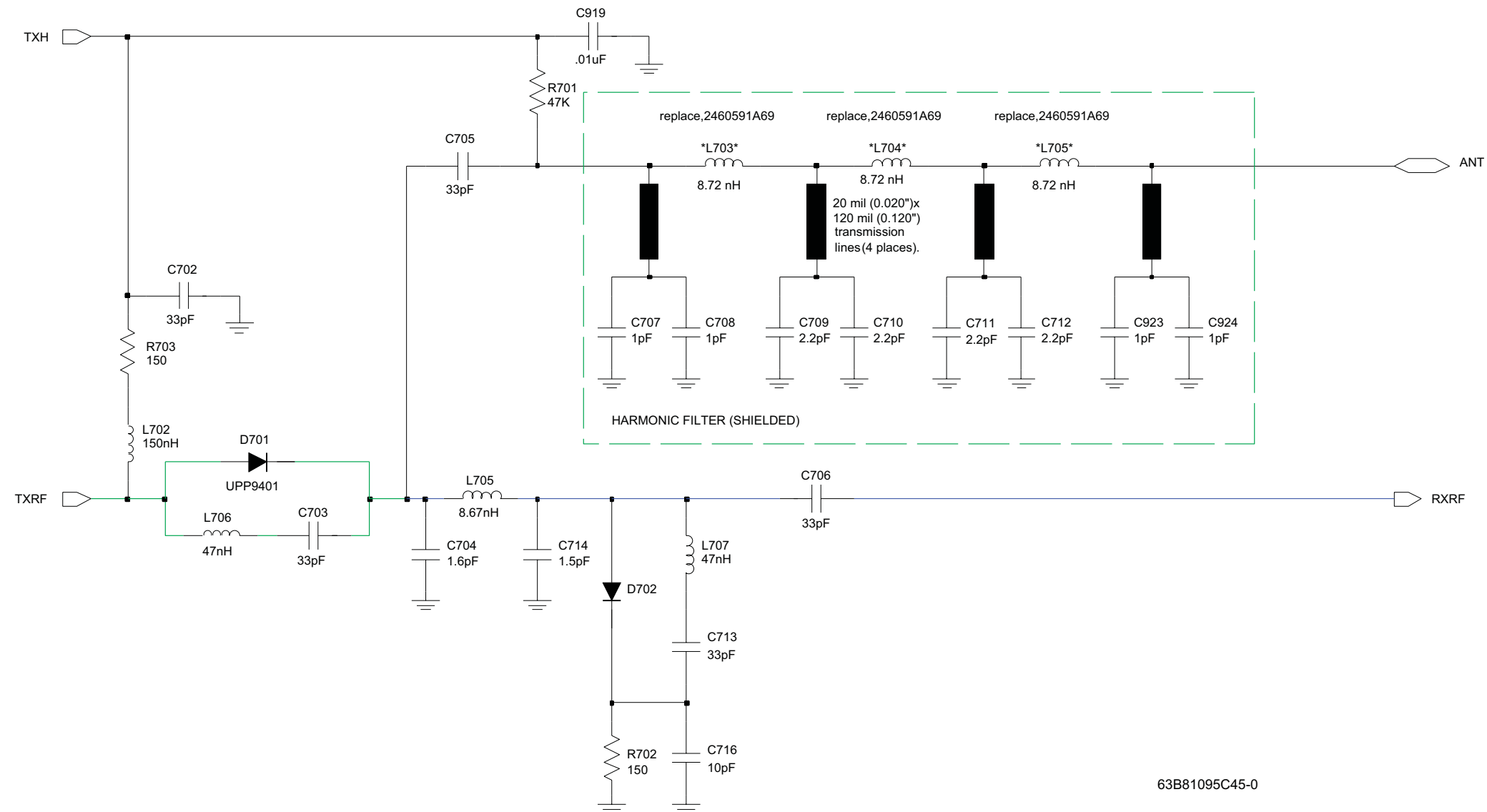

Figure 8-2. NUF3577 700–800 MHz Antenna Switch and Harmonic Filter Circuits

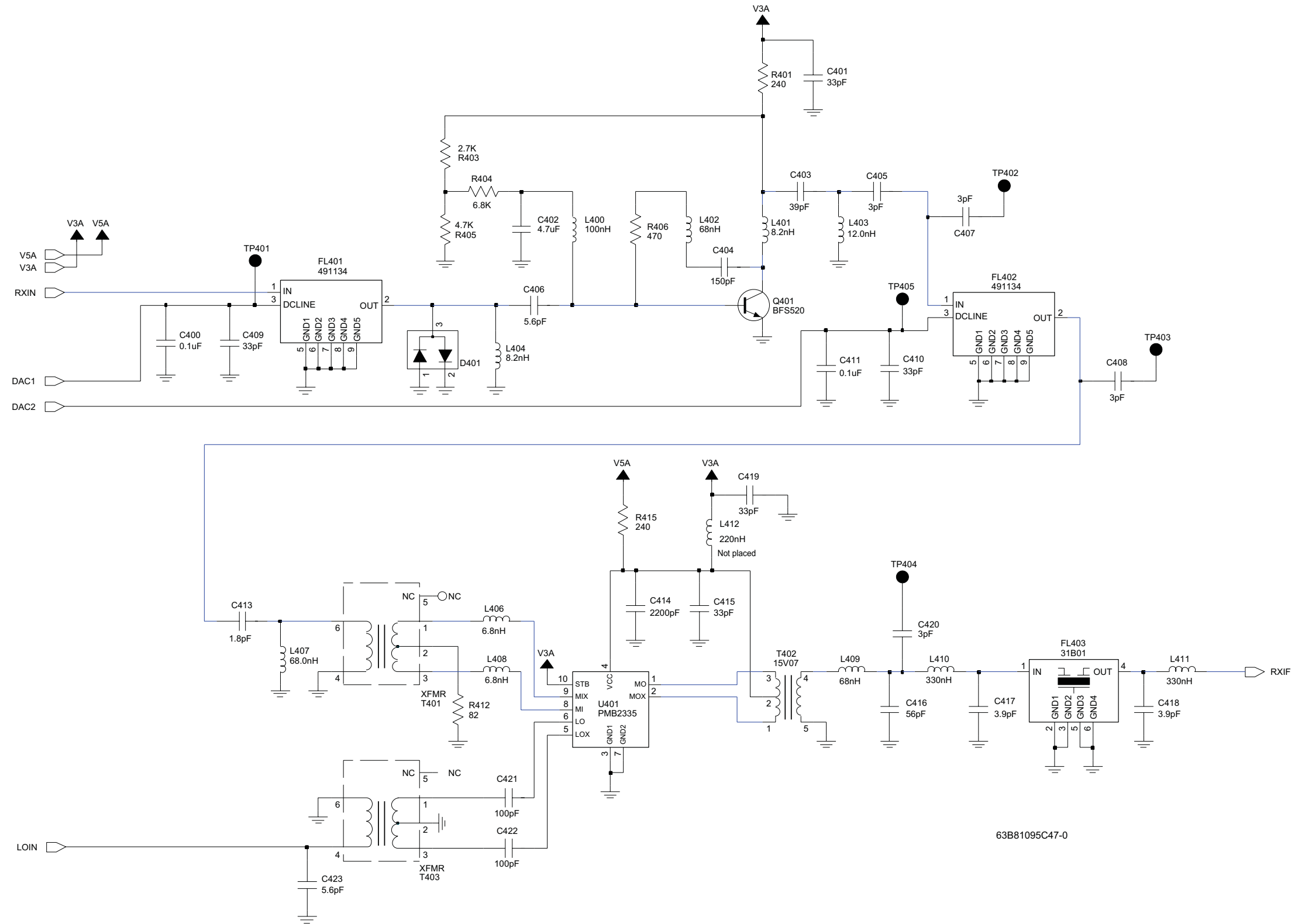

Figure 8-3. NUF3577 700–800 MHz Receiver Front End Circuit

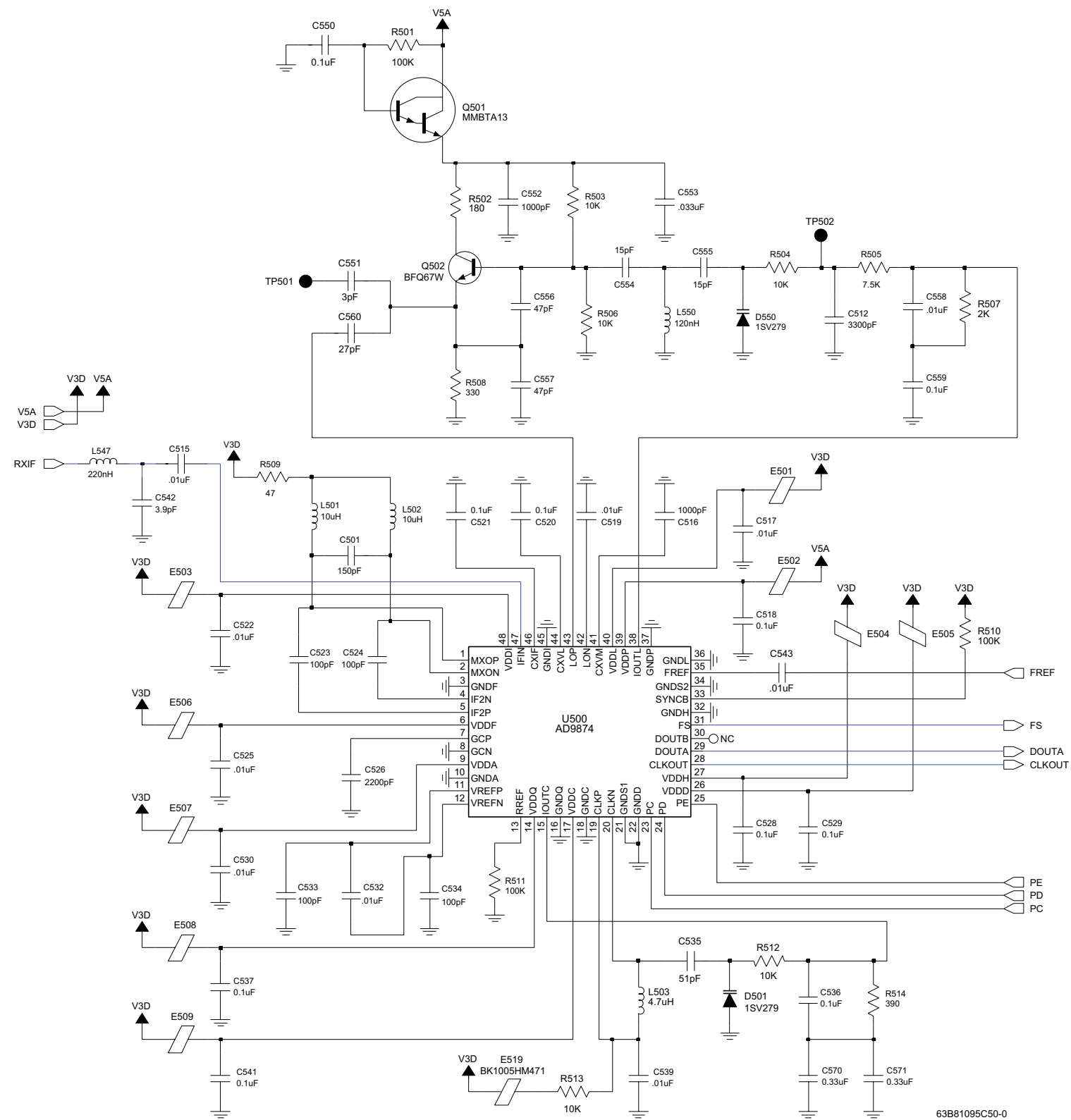

Figure 8-4. NUF3577 700–800 MHz Receiver Back End Circuit

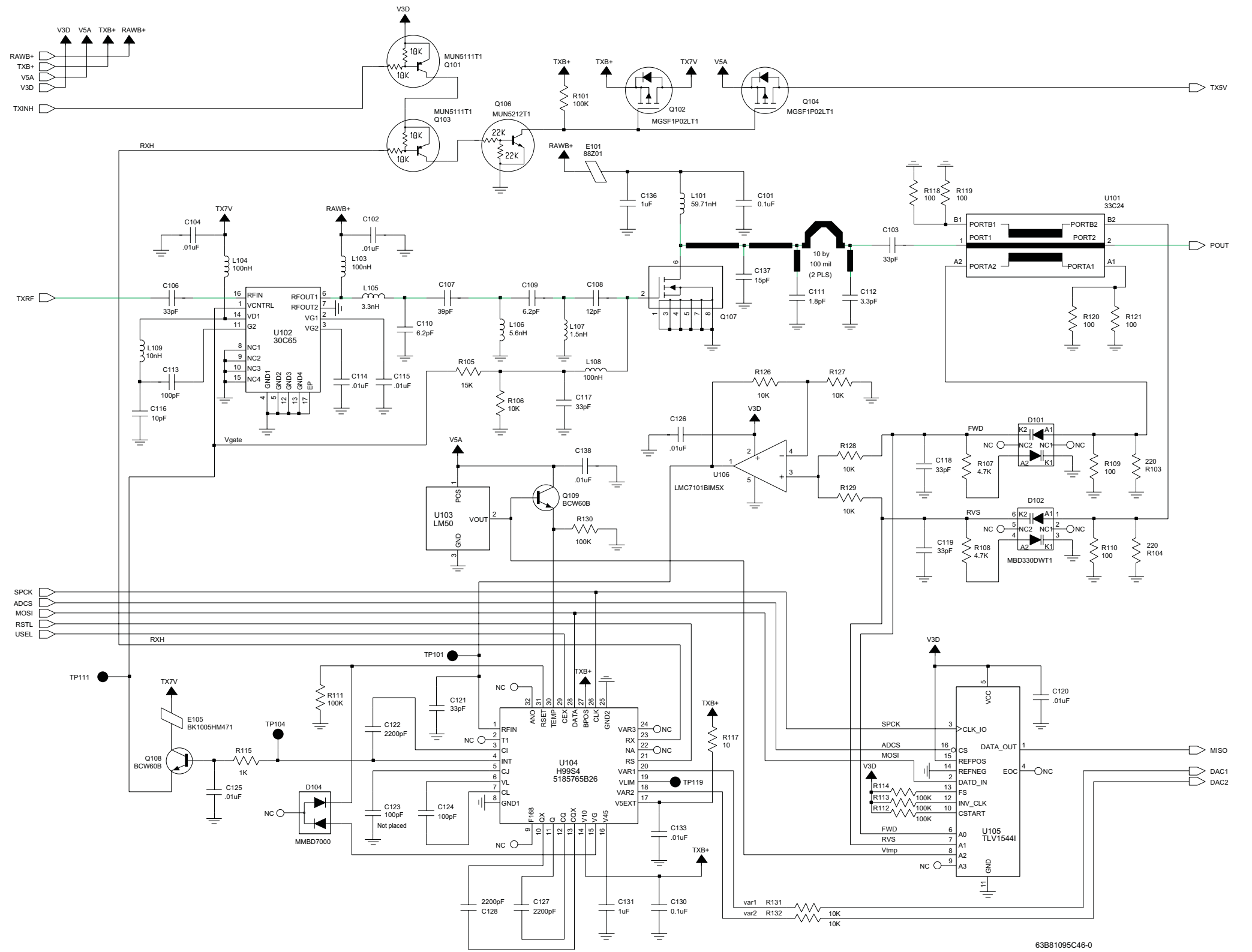

Figure 8-5. NUF3577 700–800 MHz Transmitter and Automatic Level Control Circuits

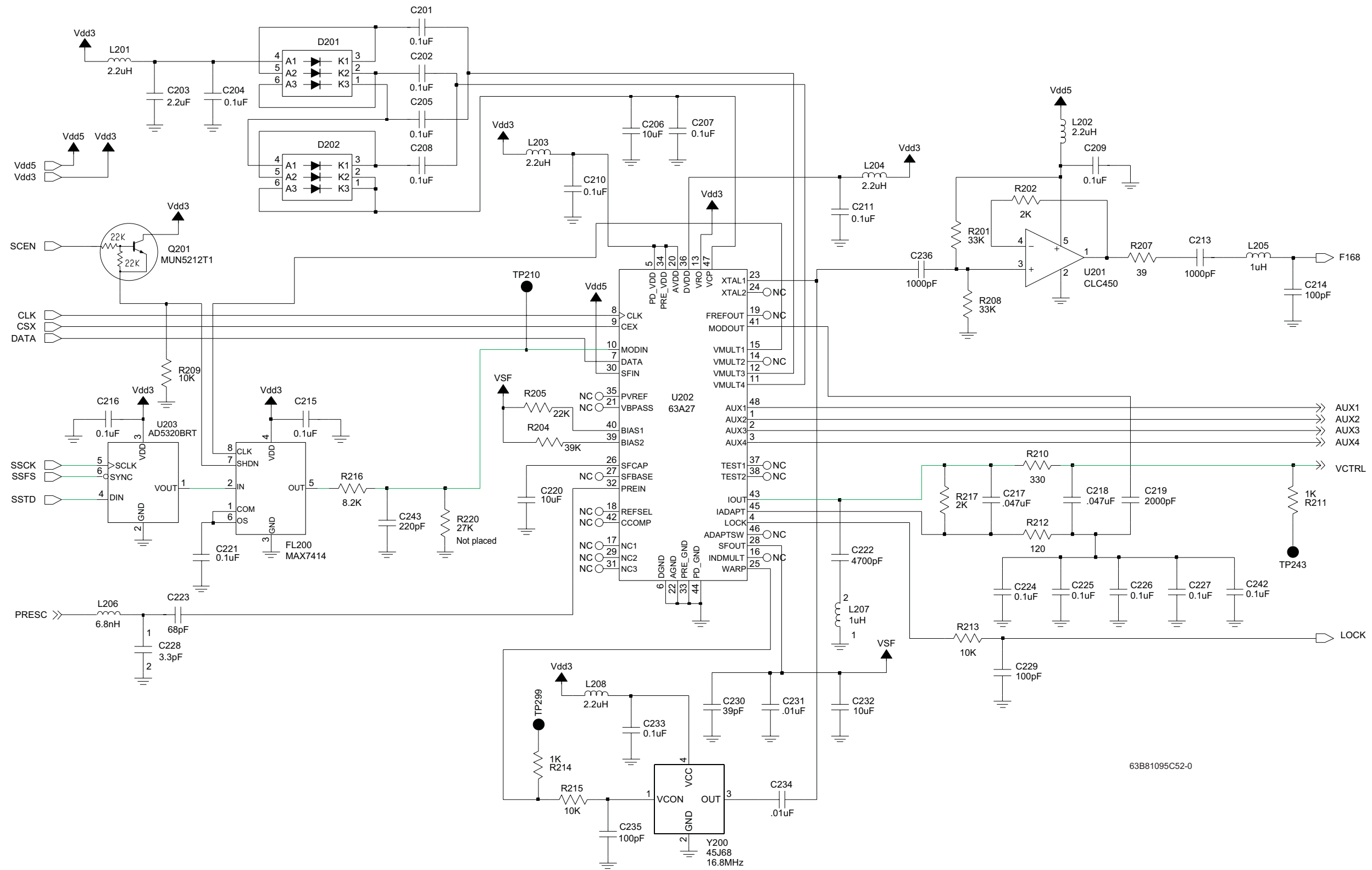

Figure 8-6. NUF3577 700-800 MHz Frequency Generation Unit (Synthesizer) Circuit—1 of 2

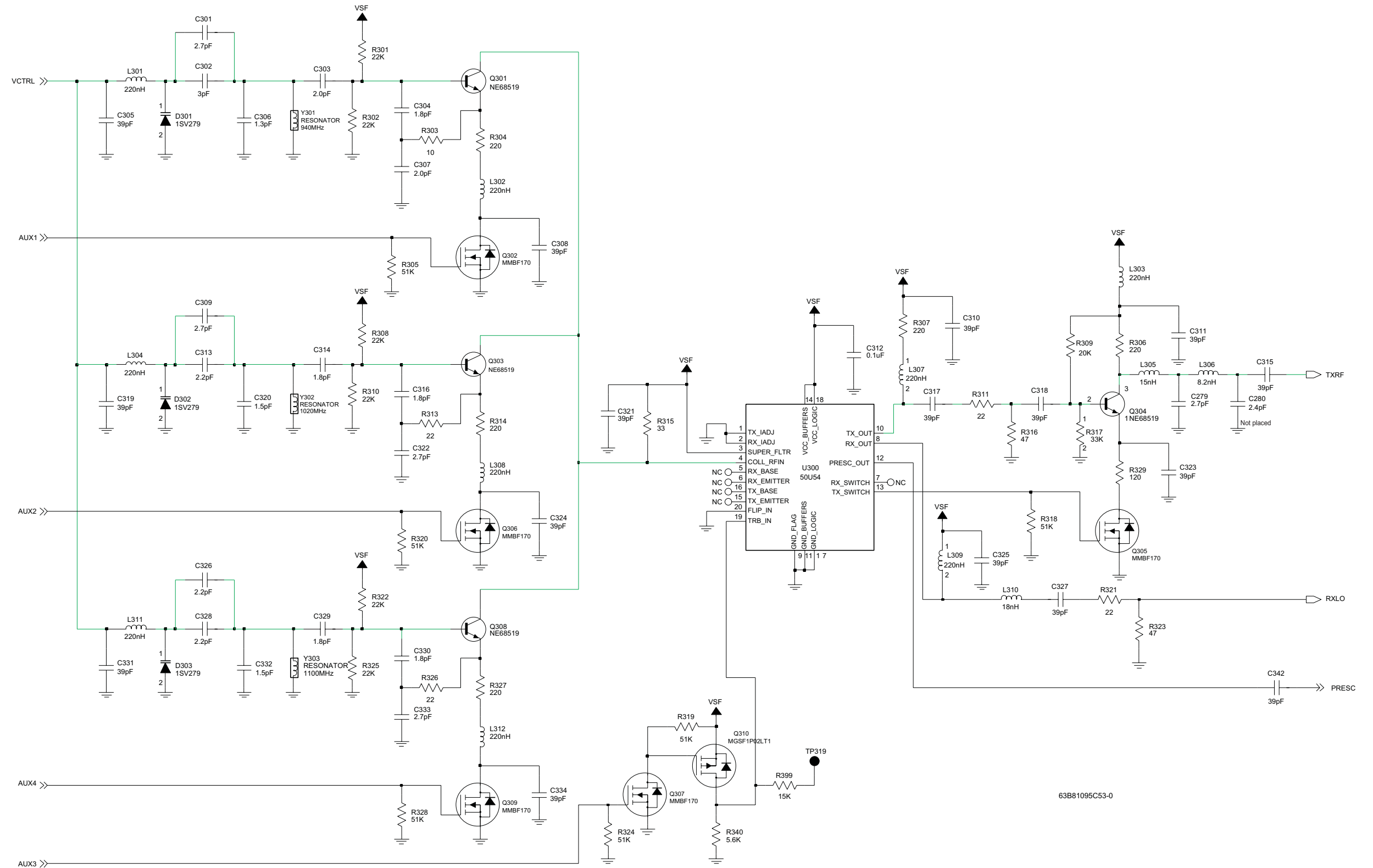

Figure 8-7. NUF3577 700–800 MHz Frequency Generation Unit (VCO) Circuit—2 of 2

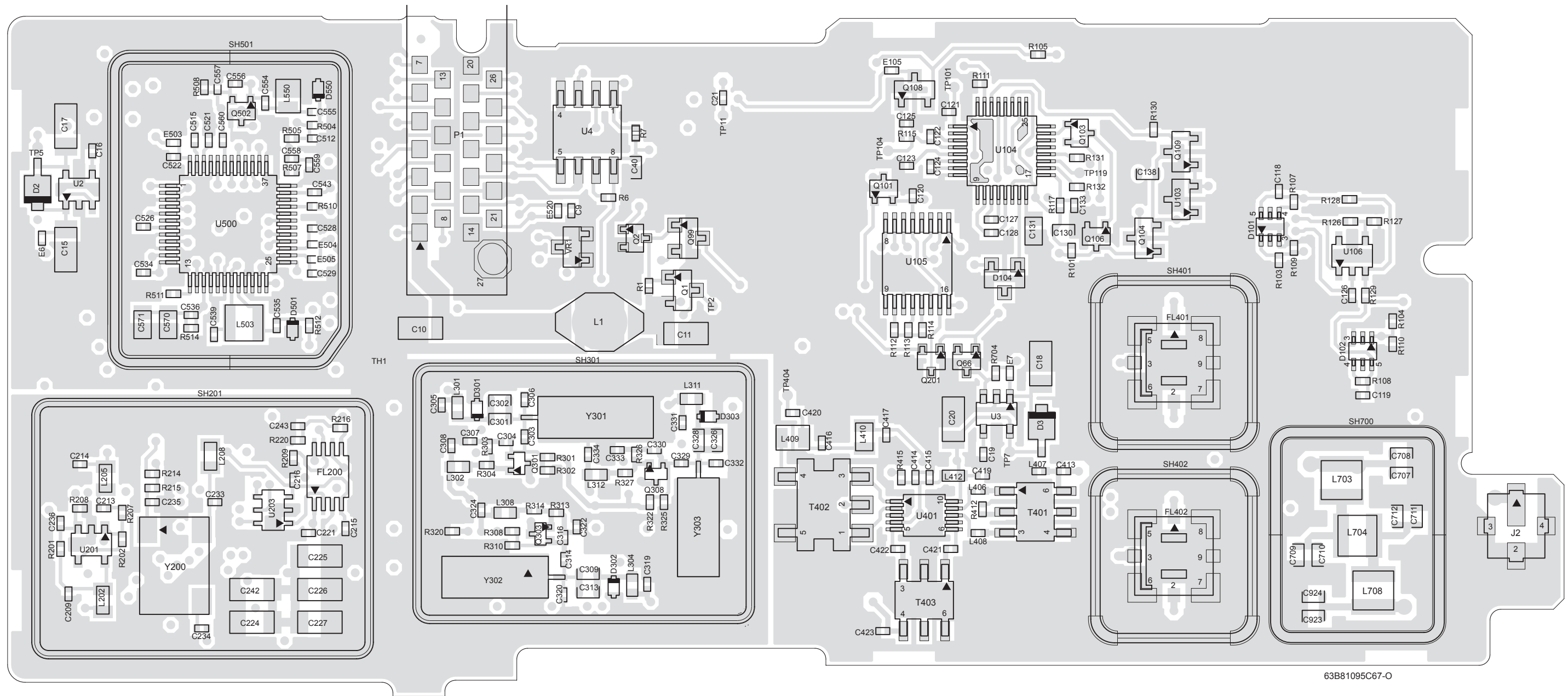
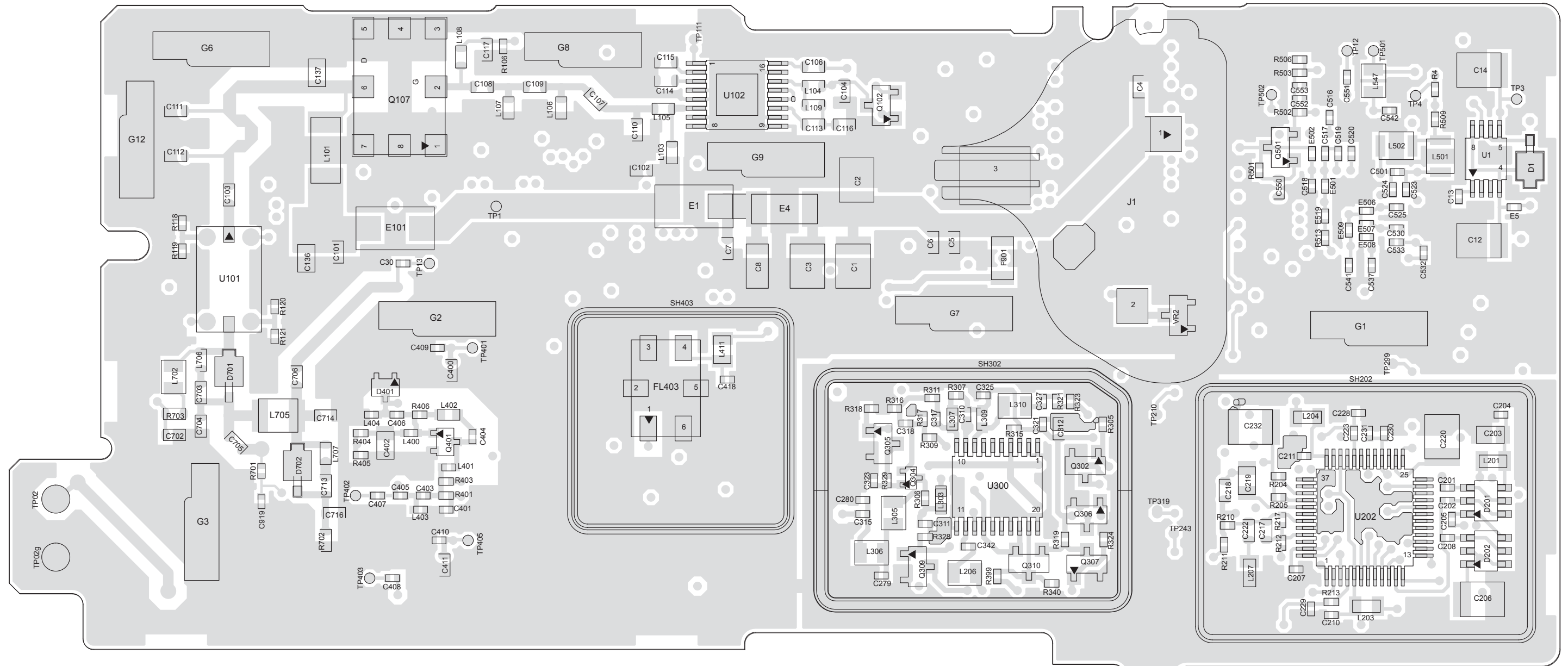

Figure 8-8. NUF3577 700–800 MHz Transceiver (RF) Board Layout—Side 1





**NUF3577 700–800 MHz Transceiver (RF)  
Board Parts List**

Ref. Des.	Part Number	Description
—	1105033S13	RIBBON LBL
—	5405569Y01	LBL BARCODE APC
—	5405569Y03	LABEL BARCODE
C1	2113743T19	CAP 10UF 16V CER 3225 X5R
C10	2113743S01	CAP CER CHIP 1.0 UF 10% 16V
C101	2113932E20	CAP CER CHP .10 UF 10% 16V
C102	2113931F49	CAP CER CHP 10,000 PF 5% 50V
C103	2113930F39	CAP CER CHP 33 PF 50V 5%
C104	2113931F49	CAP CER CHP 10,000 PF 5% 50V
C106	2113930F39	CAP CER CHP 33 PF 50V 5%
C107	2113930F41	CAP CER CHP 39 PF 50V 5%
C108	2113930F29	CAP CER CHP 12 PF 50V 5%
C109	2113930F22	CAP 6.2 PF 50V +/- .25 PF 50V
C11	2113743S01	CAP CER CHIP 1.0 UF 10% 16V
C110	2113930F22	CAP 6.2 PF 50V +/- .25 PF 50V
C111	2113930F09	CAP 1.8 PF 50V +/- 0.1 PF 50V
C112	2113930F15	CAP 3.3 PF 50V +/- .25 PF 50V
C113	2113930F51	CAP CER CHP 100 PF 50V 5%
C114	2113931F49	CAP CER CHP 10,000 PF 5% 50V
C115	2113931F49	CAP CER CHP 10,000 PF 5% 50V
C116	2113930F27	CAP CER CHP 10 PF 50V 5%
C117	2113930F39	CAP CER CHP 33 PF 50V 5%
C118	2113743N38	CAP CHIP 33.0 PF 5% COG

Ref. Des.	Part Number	Description
C119	2113743N38	CAP CHIP 33.0 PF 5% COG
C12	2113743T19	CAP 10UF 16V CER 3225 X5R
C120	2113743L41	CAP CHIP 10000 PF 10% X7R
C121	2113743N38	CAP CHIP 33.0 PF 5% COG
C122	2113743L25	CAP CHIP 2200 PF 10% X7R
C123	NOTPLACED	NOTPLACED
C124	2113743N50	CAP CHIP 100 PF 5% COG
C125	2113743L41	CAP CHIP 10000 PF 10% X7R
C126	2113743L41	CAP CHIP 10000 PF 10% X7R
C127	2113743L25	CAP CHIP 2200 PF 10% X7R
C128	2113743L25	CAP CHIP 2200 PF 10% X7R
C13	2113743L41	CAP CHIP 10000 PF 10% X7R
C130	2113932E20	CAP CER CHP .10 UF 10% 16V
C131	2113743A31	CAP CHIP 1.0UF 10% X7R
C133	2113743L41	CAP CHIP 10000 PF 10% X7R
C136	2113743A31	CAP CHIP 1.0UF 10% X7R
C137	2113742H43	CAPACITOR 15PF CERAMIC HI-Q 0805 ACCU-P
C138	2113931F49	CAP CER CHP 10,000 PF 5% 50V
C14	2113743T19	CAP 10UF 16V CER 3225 X5R
C15	2113743S01	CAP CER CHIP 1.0 UF 10% 16V
C16	2113743L41	CAP CHIP 10000 PF 10% X7R
C17	2113743S01	CAP CER CHIP 1.0 UF 10% 16V
C18	2113743S01	CAP CER CHIP 1.0 UF 10% 16V
C19	2113743L41	CAP CHIP 10000 PF 10% X7R
C2	2113743T19	CAP 10UF 16V CER 3225 X5R

Ref. Des.	Part Number	Description
C20	2113743S01	CAP CER CHIP 1.0 UF 10% 16V
C201	2113743M24	CAP CHIP 100000 PF +80-20% Y5V
C202	2113743M24	CAP CHIP 100000 PF +80-20% Y5V
C203	2113743F18	CAP CHIP 2.2 UF 16V
C204	2113743M24	CAP CHIP 100000 PF +80-20% Y5V
C205	2113743M24	CAP CHIP 100000 PF +80-20% Y5V
C206	2113743T19	CAP 10UF 16V CER 3225 X5R
C207	2113743M24	CAP CHIP 100000 PF +80-20% Y5V
C208	2113743M24	CAP CHIP 100000 PF +80-20% Y5V
C209	2113743M24	CAP CHIP 100000 PF +80-20% Y5V
C21	2113743N13	CAP CHIP 3.0 PF +/- .25PF COG
C210	2113743M24	CAP CHIP 100000 PF +80-20% Y5V
C211	2113743M24	CAP CHIP 100000 PF +80-20% Y5V
C213	2113743L17	CAP CHIP 1000 PF 10% X7R
C214	2113743N50	CAP CHIP 100 PF 5% COG
C215	2113743M24	CAP CHIP 100000 PF +80-20% Y5V
C216	2113743M24	CAP CHIP 100000 PF +80-20% Y5V
C217	2113743E12	CAP CHIP .047 UF 10% X7R
C218	2113743E12	CAP CHIP .047 UF 10% X7R
C219	2109720D20	CAP CHIP LOW DIST 2000 SOV
C220	2113743T19	CAP 10UF 16V CER 3225 X5R
C221	2113743M24	CAP CHIP 100000 PF +80-20% Y5V
C222	2113931F41	CAP CER CHP 4,700 PF 5% 50V
C223	2113743N46	QAP CHIP 68.0 PF 5% COG

Ref. Des.	Part Number	Description
C224	2109720D14	CAP CER CHIP LOW DIST .1 UF
C225	2109720D14	CAP CER CHIP LOW DIST .1 UF
C226	2109720D14	CAP CER CHIP LOW DIST .1 UF
C227	2109720D14	CAP CER CHIP LOW DIST .1 UF
C228	2113743Q14	CAP CHIP 3.3PF +/- .1 PF 20*40
C229	2113743N50	CAP CHIP 100 PF 5% COG
C230	2113743N40	CAP CHIP 39.0 PF 5% COG
C231	2113743L41	CAP CHIP 10000 PF 10% X7R
C232	2113743T19	CAP 10UF 16V CER 3225 X5R
C233	2113743M24	CAP CHIP 100000 PF +80-20% Y5V
C234	2113743L41	CAP CHIP 10000 PF 10% X7R
C235	2113743N50	CAP CHIP 100 PF 5% COG
C236	2113743L17	CAP CHIP 1000 PF 10% X7R
C242	2109720D14	CAP CER CHIP LOW DIST .1 UF
C243	2113743L01	CAP CHIP 220 PF 10% X7R
C279	2113743N12	CAP CHIP 2.7 PF +/- .25PF COG
C280	NOTPLACED	NOTPLACED
C3	2113743T19	CAP 10UF 16V CER 3225 X5R
C30	2113743N13	CAP CHIP 3.0 PF +/- .25PF COG
C301	2113740L04	CAP CER CHIP 2.7 PF +/- 0.1PF
C302	2113740L05	CAP CER CHIP 3.0 PF +/- 0.1PF
C303	2104801Z13	CAP CER NPO 2.0PF 16V 1005 SMD
C304	2104801Z12	CAP CER NPO 1.8PF 16V 1005 SMD
C305	2113743N40	CAP CHIP 39.0 PF 5% COG
C306	2104801Z09	CAP XTS 5000 RF PCB
C307	2104801Z13	CAP CER NPO 2.0PF 16V 1005 SMD

Ref. Des.	Part Number	Description
C308	2113743N40	CAP CHIP 39.0 PF 5% COG
C309	2113740L04	CAP CER CHIP 2.7 PF +/- 0.1PF
C310	2113743N40	CAP CHIP 39.0 PF 5% COG
C311	2113743N40	CAP CHIP 39.0 PF 5% COG
C312	2113932E20	CAP CER CHP .10 UF 10% 16V
C313	2113740L02	CAP CER CHIP 2.2 PF +/- 0.1PF
C314	2104801Z12	CAP CER NPO 1.8PF 16V 1005 SMD
C315	2113743N40	CAP CHIP 39.0 PF 5% COG
C316	2104801Z12	CAP CER NPO 1.8PF 16V 1005 SMD
C317	2113743N40	CAP CHIP 39.0 PF 5% COG
C318	2113743N40	CAP CHIP 39.0 PF 5% COG
C319	2113743N40	CAP CHIP 39.0 PF 5% COG
C320	2104801Z10	CAP CER NPO 1.5PF 16V 1005 SMD
C321	2113743N40	CAP CHIP 39.0 PF 5% COG
C322	2104801Z16	CAP CER NPO 2.7PF 16V 1005 SMD
C323	2113743N40	CAP CHIP 39.0 PF 5% COG
C324	2113743N40	CAP CHIP 39.0 PF 5% COG
C325	2113743N40	CAP CHIP 39.0 PF 5% COG
C326	2113740L02	CAP CER CHIP 2.2 PF +/- 0.1PF
C327	2113743N40	CAP CHIP 39.0 PF 5% COG
C328	2113740L02	CAP CER CHIP 2.2 PF +/- 0.1PF
C329	2104801Z12	CAP CER NPO 1.8PF 16V 1005 SMD
C330	2104801Z12	CAP CER NPO 1.8PF 16V 1005 SMD
C331	2113743N40	CAP CHIP 39.0 PF 5% COG
C332	2104801Z10	CAP CER NPO 1.5PF 16V 1005 SMD
C333	2104801Z16	CAP CER NPO 2.7PF 16V 1005 SMD
C334	2113743N40	CAP CHIP 39.0 PF 5% COG
C342	2113743N40	CAP CHIP 39.0 PF 5% COG
C4	2113931F49	CAP CER CHP 10,000 PF 5% 50V

Ref. Des.	Part Number	Description
C40	2113932E20	CAP CER CHP .10 UF 10% 16V
C400	2113932E20	CAP CER CHP .10 UF 10% 16V
C401	2113743N38	CAP CHIP 33.0 PF 5% COG
C402	2113928C04	CAP CER CHIP 4.7UF 6.3V10%0805
C403	2113743N40	CAP CHIP 39.0 PF 5% COG
C404	2113743N54	CAP CHIP 150 PF 5% COG
C405	2113743N13	CAP CHIP 3.0 PF +/- .25PF COG
C406	2113743N20	CAP CHIP 5.6PF +/- .5PF COG
C407	2113743N13	CAP CHIP 3.0 PF +/- .25PF COG
C408	2113743N13	CAP CHIP 3.0 PF +/- .25PF COG
C409	2113743N38	CAP CHIP 33.0 PF 5% COG
C410	2113743N38	CAP CHIP 33.0 PF 5% COG
C411	2113932E20	CAP CER CHP .10 UF 10% 16V
C413	2104801Z12	CAP CER NPO 1.8PF 16V 1005 SMD
C414	2113743L25	CAP CHIP 2200 PF 10% X7R
C415	2113743N38	CAP CHIP 33.0 PF 5% COG
C416	2113743N44	CAP CHIP 56.0 PF 5% COG
C417	2113743N16	CAP CHIP 3.9PF +/- .25PF COG
C418	2113743N16	CAP CHIP 3.9PF +/- .25PF COG
C419	2113743N38	CAP CHIP 33.0 PF 5% COG
C420	2113743N13	CAP CHIP 3.0 PF +/- .25PF COG
C421	2113743N50	CAP CHIP 100 PF 5% COG
C422	2113743N50	CAP CHIP 100 PF 5% COG
C423	2113743N20	CAP CHIP 5.6PF +/- .5PF COG
C5	2113930F24	C~P 7.5 PF 50V +/- .25 PF 50V
C501	2113743N54	CAP CHIP 150 PF 5% COG
C512	2113743L29	CAP CHIP 3300 PF 10% X7R

Ref. Des.	Part Number	Description
C515	2113743L41	CAP CHIP 10000 PF 10% X7R
C516	2113743L17	CAP CHIP 1000 PF 10% X7R
C517	2113743L41	CAP CHIP 10000 PF 10% X7R
C518	2113928N01	CAP CER CHIP 0.1UF 10% 6.3
C519	2113743L41	CAP CHIP 10000 PF 10% X7R
C520	2113928N01	CAP CER CHIP 0.1UF 10% 6.3
C521	2113928N01	CAP CER CHIP 0.1UF 10% 6.3
C522	2113743L41	CAP CHIP 10000 PF 10% X7R
C523	2113743N50	CAP CHIP 100 PF 5% COG
C524	2113743N50	CAP CHIP 100 PF 5% COG
C525	2113743L41	CAP CHIP 10000 PF 10% X7R
C526	2113743L25	CAP CHIP 2200 PF 10% X7R
C528	2113928N01	CAP CER CHIP 0.1UF 10% 6.3
C529	2113928N01	CAP CER CHIP 0.1UF 10% 6.3
C530	2113743L41	CAP CHIP 10000 PF 10% X7R
C532	2113743L41	CAP CHIP 10000 PF 10% X7R
C533	2113743N50	CAP CHIP 100 PF 5% COG
C534	2113743N50	CAP CHIP 100 PF 5% COG
C535	2113743N43	CAP CHIP 51.0 PF 5% COG
C536	2113928N01	CAP CER CHIP 0.1UF 10% 6.3
C537	2113928N01	CAP CER CHIP 0.1UF 10% 6.3
C539	2113743L41	CAP CHIP 10000 PF 10% X7R
C541	2113928N01	CAP CER CHIP 0.1UF 10% 6.3
C542	2113743N16	CAP CHIP 3.9PF +/- .25PF COG
C543	2113743L41	CAP CHIP 10000 PF 10% X7R

Ref. Des.	Part Number	Description
C550	2113932E20	CAP CER CHP .10 UF 10% 16V
C551	2113743N13	CAP CHIP 3.0 PF +/- .25PF COG
C552	2113743L17	CAP CHIP 1000 PF 10% X7R
C553	2113743L50	CAP CHIP 33000 PF 10%
C554	2113743N30	CAP CHIP 15.0 PF 5% COG
C555	2113743N30	CAP CHIP 15.0 PF 5% COG
C556	2113743N42	CAP CHIP 47.0 PF 5% COG
C557	2113743N42	CAP CHIP 47.0 PF 5% COG
C558	2113743L41	CAP CHIP 10000 PF 10% X7R
C559	2113928N01	CAP CER CHIP 0.1UF 10% 6.3
C560	2113743N36	CAP CHIP 27.0 PF 5% COG
C570	2113743A24	CAP CHIP .330 UF 10% 16V
C571	2113743A24	CAP CHIP .330 UF 10% 16V
C6	2113930F39	CAP CER CHP 33 PF 50V 5%
C7	2113930F24	C~P 7.5 PF 50V +/- .25 PF 50V
C702	2113930F39	CAP CER CHP 33 PF 50V 5%
C703	2113930F39	CAP CER CHP 33 PF 50V 5%
C704	2113930F08	CAP 1.6 PF 50V +/- .0.1 PF 50V
C705	2113930F39	CAP CER CHP 33 PF 50V 5%
C706	2113930F39	CAP CER CHP 33 PF 50V 5%
C707	2113930F03	CAP 1.0 PF 50V +/- .0.1 PF 50V
C708	2113930F03	CAP 1.0 PF 50V +/- .0.1 PF 50V
C709	2113930F11	CAP 2.2 PF 50V +/- .25 PF 50V
C710	2113930F11	CAP 2.2 PF 50V +/- .25 PF 50V
C711	2113930F11	CAP 2.2 PF 50V +/- .25 PF 50V

Ref. Des.	Part Number	Description
C712	2113930F11	CAP 2.2 PF 50V +/- .25 PF 50V
C713	2113930F39	CAP CER CHP 33 PF 50V 5%
C714	2113930F07	CAP 1.5 PF 50V +/- .0.1 PF 50V
C716	2113930F27	CAP CER CHP 10 PF 50V 5%
C8	2113743S01	CAP CER CHIP 1.0 UF 10% 16V
C9	2113743N50	CAP CHIP 100 PF 5% COG
C919	2113743L41	CAP CHIP 10000 PF 10% X7R
C923	2113930F03	CAP 1.0 PF 50V +/- .0.1 PF 50V
C924	2113930F03	CAP 1.0 PF 50V +/- .0.1 PF 50V
D1	4813833A20	DIODE SCHOTTKY 1A 40V PWRMITE
D101	4802197J83	DUAL SHOTTKY DIODE MBD330DWT1
D102	4802197J83	DUAL SHOTTKY DIODE MBD330DWT1
D104	4805129M06	DIODE MMBD7000
D2	4813833A20	DIODE SCHOTTKY 1A 40V PWRMITE
D201	4802233J09	DIODE TRIPLE SOT25-RH
D202	4802233J09	DIODE TRIPLE SOT25-RH
D3	4813833A20	DIODE SCHOTTKY 1A 40V PWRMITE
D301	4809877C08	DIODE VARACTOR 1SV279 SMD
D302	4809877C08	DIODE VARACTOR 1SV279 SMD
D303	4809877C08	DIODE VARACTOR 1SV279 SMD
D401	4813825A19	DIODE SCHOTTKY BARRIER SERIES
D501	4809877C08	DIODE VARACTOR 1SV279 SMD
D550	4809877C08	DIODE VARACTOR 1SV279 SMD
D701	4805656W24	DIODE, PIN RF
D702	4805656W24	DIODE, PIN RF

Ref. Des.	Part Number	Description
E1	2405688Z01	INDUCTOR FERRITE BEAD
E101	2405688Z01	INDUCTOR FERRITE BEAD
E105	2480640Z01	SURFACE MOUNT FERRITE BEAD
E4	2460591K40	COIL AIR WOUND INDUC 59.71
E5	2480640Z01	SURFACE MOUNT FERRITE BEAD
E501	2480640Z01	SURFACE MOUNT FERRITE BEAD
E502	2480640Z01	SURFACE MOUNT FERRITE BEAD
E503	2480640Z01	SURFACE MOUNT FERRITE BEAD
E504	2480640Z01	SURFACE MOUNT FERRITE BEAD
E505	2480640Z01	SURFACE MOUNT FERRITE BEAD
E506	2480640Z01	SURFACE MOUNT FERRITE BEAD
E507	2480640Z01	SURFACE MOUNT FERRITE BEAD
E508	2480640Z01	SURFACE MOUNT FERRITE BEAD
E509	2480640Z01	SURFACE MOUNT FERRITE BEAD
E519	2480640Z01	SURFACE MOUNT FERRITE BEAD
E520	2480640Z01	SURFACE MOUNT FERRITE BEAD
E6	2409154M48	IND CER MLTILYR 1.0NH 1005
E7	2409154M48	IND CER MLTILYR 1.0NH 1005
F901	6505757V02	FUSE SURFACE MT 2AMP
FL200	9185130D01	FLTR SW CAP 3 POLE BUTTERW
FL401	9185004D01	LC FLTR, MULTILAYER CERAMIC
FL402	9185004D01	LC FLTR, MULTILAYER CERAMIC
FL403	4885631B01	XTAL FILT 3 POLE 109.65 MOTORO
G1	3905643V01	CONTACT ANT GRD

Ref. Des.	Part Number	Description
G12	3905643V01	CONTACT ANT GRD
G2	3905643V01	CONTACT ANT GRD
G3	3905643V01	CONTACT ANT GRD
G6	3905643V01	CONTACT ANT GRD
G7	3905643V01	CONTACT ANT GRD
G8	3905643V01	CONTACT ANT GRD
G9	3905643V01	CONTACT ANT GRD
J1	NOTPLACED	NOTPLACED
J2	0905304Z01	CONN COAXIAL SMT
L1	2486085A04	COIL, 6.8 UH POWER INDUCTOR
L101	2460591K40	COIL AIR WOUND INDUC 59.71
L103	2413926H24	INDUCTOR MULITI-LAYER CERAMIC CHIP
L104	2413926H24	INDUCTOR MULITI-LAYER CERAMIC CHIP
L105	2413926H06	IND CHIP 3.3 NH +/- 0.3NH
L106	2413926H09	IND CHIP 5.6 NH +/- 0.3NH
L107	2413926F02	IND 1.5 NH +/- 0.3 NH
L108	2413926H24	INDUCTOR MULITI-LAYER CERAMIC CHIP
L109	2413926H12	CHIP INDUCTOR 10.0NH
L201	2462587Q20	IND CHIP 2,200 NH 20%
L202	2462587Q20	IND CHIP 2,200 NH 20%
L203	2462587Q20	IND CHIP 2,200 NH 20%
L204	2462587Q20	IND CHIP 2,200 NH 20%
L205	2462587Q47	IND CHIP 1,000 NH 10%
L206	2462587V21	CHIP IND 6.8 NH 5% 0805
L207	2462587Q47	IND CHIP 1,000 NH 10%
L208	2462587Q20	IND CHIP 2,200 NH 20%
L301	2409377M36	IND CHIP WW 220 NH 5% 1608
L302	2409377M36	IND CHIP WW 220 NH 5% 1608
L303	2409377M36	IND CHIP WW 220 NH 5% 1608
L304	2409377M36	IND CHIP WW 220 NH 5% 1608
L305	2462587V24	CHIP IND 15 NH 5% 0805
L306	2462587V22	CHIP IND 8.2 NH 5% 0805

Ref. Des.	Part Number	Description
L307	2409377M36	IND CHIP WW 220 NH 5% 1608
L308	2409377M36	IND CHIP WW 220 NH 5% 1608
L309	2409377M36	IND CHIP WW 220 NH 5% 1608
L310	2462587V25	CHIP IND 18 NH 5% 0805
L311	2409377M36	IND CHIP WW 220 NH 5% 1608
L312	2409377M36	IND CHIP WW 220 NH 5% 1608
L400	2409154M48	IND CER MLTILYR 1.0NH 1005
L401	2409154M12	IND MTLILYR 8.2NH 1005
L402	2409377M14	IND CHIP WW 68 NH 5% 1608
L403	2409154M14	IND CER MLTILYR 12.0NH 1005
L404	2409154M12	IND MTLILYR 8.2NH 1005
L406	2409154M11	IND MTLILYR 6.8NH 1005
L407	2409154M23	IND CER MLTILYR 68.0NH 1005
L408	2409154M11	IND MTLILYR 6.8NH 1005
L409	2462587V32	CHIP IND 68 NH 5% 0805
L410	2404574Z15	IND CHIP WW 330NH 2% 2012 SMD
L411	2404574Z15	IND CHIP WW 330NH 2% 2012 SMD
L412	NOTPLACED	NOTPLACED
L501	2405769X05	COIL INDUCTOR
L502	2405769X05	COIL INDUCTOR
L503	2462587N76	CHIP IND 4700 NH 5%
L547	2462587V38	CHIP IND 220 NH 5% 0805
L550	2462587V35	CHIP IND 120 NH 5% 0805
L702	2462587V36	CHIP IND 150 NH 5% 0805
L703	2460591A69	COIL AIR WOUND INDUC 8.72
L704	2460591A69	COIL AIR WOUND INDUC 8.72
L705	2460591B22	COIL AIR WOUND INDUC 8.67
L706	2413926G15	IND 47.0 NH 5%
L707	2413926G15	IND 47.0 NH 5%

Ref. Des.	Part Number	Description
L708	2460591A69	COIL AIR WOUND INDUC 8.72
P1	NOTPLACED	NOTPLACED
PCB	8485013D01	BD PC RF XCVR
Q1	4813821A47	TSTR P-CH HDTMOS 20V
Q101	4813824A42	TSTR PNP 50V BIAS RES 10K 10K
Q102	4813821A47	TSTR P-CH HDTMOS 20V
Q103	4813824A42	TSTR PNP 50V BIAS RES 10K 10K
Q104	4813821A47	TSTR P-CH HDTMOS 20V
Q106	4813824A39	TSTR NPN 50V BIAS RES 22K 22K
Q107	5185633C10	MODE 800 MHz RING
Q108	4805128M12	TSTR SOT BCW 60B (RH)
Q109	4805128M12	TSTR SOT BCW 60B (RH)
Q2	4813824A39	TSTR NPN 50V BIAS RES 22K 22K
Q201	4813824A39	TSTR NPN 50V BIAS RES 22K 22K
Q301	4805793Y01	TRANS MINI SOT NPN LOW NOISE
Q302	4805218N11	XISTOR SOT RH BST82
Q303	4805793Y01	TRANS MINI SOT NPN LOW NOISE
Q304	4805793Y01	TRANS MINI SOT NPN LOW NOISE
Q305	4805218N11	XISTOR SOT RH BST82
Q306	4805218N11	XISTOR SOT RH BST82
Q307	4805218N11	XISTOR SOT RH BST82
Q308	4805793Y01	TRANS MINI SOT NPN LOW NOISE
Q309	4805218N11	XISTOR SOT RH BST82
Q310	4813821A47	TSTR P-CH HDTMOS 20V
Q401	4805585Q19	TRANSISTOR
Q501	4805128M19	TSTR SOT23 MMBTA13 RH
Q502	4805218N63	RF TRANS SOT 323 Bfq67w
Q66	4813824A39	TSTR NPN 50V BIAS RES 22K 22K
Q99	4813821A47	TSTR P-CH HDTMOS 20V
R1	0662057N23	RES. CHIP 100K 5% 20X40

Ref. Des.	Part Number	Description
R101	0662057N23	RES. CHIP 100K 5% 20X40
R103	0662057M58	RES. CHIP 220 5% 20X40
R104	0662057M58	RES. CHIP 220 5% 20X40
R105	0662057N03	RES. CHIP 15K 5% 20X40
R106	0662057M98	RES. CHIP 10K 5% 20X40
R107	0662057M90	RES. CHIP 4700 5% 20X40
R108	0662057M90	RES. CHIP 4700 5% 20X40
R109	0662057M50	RES. CHIP 100 5% 20X40
R110	0662057M50	RES. CHIP 100 5% 20X40
R111	0662057N23	RES. CHIP 100K 5% 20X40
R112	0662057N23	RES. CHIP 100K 5% 20X40
R113	0662057N23	RES. CHIP 100K 5% 20X40
R114	0662057N23	RES. CHIP 100K 5% 20X40
R115	0662057M74	RES. CHIP 1000 5% 20X40
R117	0662057M26	RES. CHIP 10 5% 20X40
R118	0662057M50	RES. CHIP 100 5% 20X40
R119	0662057M50	RES. CHIP 100 5% 20X40
R120	0662057M50	RES. CHIP 100 5% 20X40
R121	0662057M50	RES. CHIP 100 5% 20X40
R126	0662057M98	RES. CHIP 10K 5% 20X40
R127	0662057M98	RES. CHIP 10K 5% 20X40
R128	0662057M98	RES. CHIP 10K 5% 20X40
R129	0662057M98	RES. CHIP 10K 5% 20X40
R130	0662057N23	RES. CHIP 100K 5% 20X40
R131	0662057M98	RES. CHIP 10K 5% 20X40
R132	0662057M98	RES. CHIP 10K 5% 20X40
R201	0662057N11	RES. CHIP 33K 5% 20X40
R202	0662057M81	RES. CHIP 2000 5% 20X40
R204	0662057N13	RES. CHIP 39K 5% 20X40
R205	0662057N07	RES. CHIP 22K 5% 20X40
R207	0662057M40	RES. CHIP 39 5% 20X40
R208	0662057N11	RES. CHIP 33K 5% 20X40
R209	0662057M98	RES. CHIP 10K 5% 20X40
R210	0662057M62	RES. CHIP 330 5% 20X40
R211	0662057M74	RES. CHIP 1000 5% 20X40
R212	0662057M52	RES. CHIP 120 5% 20X40
R213	0662057M98	RES. CHIP 10K 5% 20X40
R214	0662057M74	RES. CHIP 1000 5% 20X40
R215	0662057M98	RES. CHIP 10K 5% 20X40

Ref. Des.	Part Number	Description
R216	0662057M96	RES. CHIP 8200 5% 20X40
R217	0662057M81	RES. CHIP 2000 5% 20X40
R220	NOTPLACED	NOTPLACED
R301	0662057N07	RES. CHIP 22K 5% 20X40
R302	0662057N07	RES. CHIP 22K 5% 20X40
R303	0662057M26	RES. CHIP 10 5% 20X40
R304	0662057M58	RES. CHIP 220 5% 20X40
R305	0662057N16	RES. CHIP 51K 5% 20X40
R306	0662057M58	RES. CHIP 220 5% 20X40
R307	0662057M58	RES. CHIP 220 5% 20X40
R308	0662057N07	RES. CHIP 22K 5% 20X40
R309	0662057N06	RES. CHIP 20K 5% 20X40
R310	0662057N07	RES. CHIP 22K 5% 20X40
R311	0662057M34	RES. CHIP 22 5% 20X40
R313	0662057M34	RES. CHIP 22 5% 20X40
R314	0662057M58	RES. CHIP 220 5% 20X40
R315	0662057M38	RES. CHIP 33 5% 20X40
R316	0662057M42	RES. CHIP 47 5% 20X40
R317	0662057N11	RES. CHIP 33K 5% 20X40
R318	0662057N16	RES. CHIP 51K 5% 20X40
R319	0662057N16	RES. CHIP 51K 5% 20X40
R320	0662057N16	RES. CHIP 51K 5% 20X40
R321	0662057M34	RES. CHIP 22 5% 20X40
R322	0662057N07	RES. CHIP 22K 5% 20X40
R323	0662057M42	RES. CHIP 47 5% 20X40
R324	0662057N16	RES. CHIP 51K 5% 20X40
R325	0662057N07	RES. CHIP 22K 5% 20X40
R326	0662057M34	RES. CHIP 22 5% 20X40
R327	0662057M58	RES. CHIP 220 5% 20X40
R328	0662057N16	RES. CHIP 51K 5% 20X40
R329	0662057M52	RES. CHIP 120 5% 20X40
R340	0662057M92	RES. CHIP 5600 5% 20X40
R399	0662057N03	RES. CHIP 15K 5% 20X40
R4	2113743L17	CAP CHIP 1000 PF 10% X7R
R401	0662057M59	RES CHIP 240 5% 20X40
R403	0662057M84	RES. CHIP 2700 5% 20X40
R404	0662057M94	RES. CHIP 6800 5% 20X40
R405	0662057M90	RES. CHIP 4700 5% 20X40

Ref. Des.	Part Number	Description
R406	0662057M66	RES. CHIP 470 5% 20X40
R412	0662057M48	RES. CHIP 82 5% 20X40
R415	0662057M59	RES CHIP 240 5% 20X40
R501	0662057N23	RES. CHIP 100K 5% 20X40
R502	0662057M56	RES. CHIP 180 5% 20X40
R503	0662057M98	RES. CHIP 10K 5% 20X40
R504	0662057M98	RES. CHIP 10K 5% 20X40
R505	0662057M95	RES. CHIP 7500 5% 20X40
R506	0662057M98	RES. CHIP 10K 5% 20X40
R507	0662057M81	RES. CHIP 2000 5% 20X40
R508	0662057M62	RES. CHIP 330 5% 20X40
R509	0662057M42	RES. CHIP 47 5% 20X40
R510	0662057N23	RES. CHIP 100K 5% 20X40
R511	0662057N23	RES. CHIP 100K 5% 20X40
R512	0662057M98	RES. CHIP 10K 5% 20X40
R513	0662057M98	RES. CHIP 10K 5% 20X40
R514	0662057M64	RES. CHIP 390 5% 20X40
R6	0662057M98	RES. CHIP 10K 5% 20X40
R7	0662057M98	RES. CHIP 10K 5% 20X40
R701	0662057N15	RES. CHIP 47K 5% 20X40
R702	0662057A29	CHIP RES 150 OHMS 5%
R703	0662057A29	CHIP RES 150 OHMS 5%
R704	0662057N23	RES. CHIP 100K 5% 20X40
SH201	2685787B01	SHLD FRAC-N
SH202	2685787B01	SHLD FRAC-N
SH301	2685297D01	SHLD VCO
SH302	2685298D01	SHLD VCO BUFFER
SH401	2685627A02	SHLD DUAL INDUCTOR
SH402	2685627A02	SHLD DUAL INDUCTOR
SH403	2685882A01	SHLD VCO TANK
SH501	2685298D01	SHLD VCO BUFFER
SH700	2685762D01	SHEILD HARMONIC FILTER
T401	2580541Z02	BALUN TRANSFORMER (NEW)
T402	2505515V07	XFMR JEDI MIXER 25:1
T403	2580541Z02	BALUN TRANSFORMER (NEW)
TH1	NOTPLACED	NOTPLACED

Ref. Des.	Part Number	Description
U1	5185353D13	IC MINI SO-8 HI PRECISION REG 5V
U101	5185633C24	MODULE DIRECT COUPLER
U102	5185130C65	IC VHF/UHF/800 MHZ LDMOS DRIVER
U103	5185963A15	IC TEMPERTURE SENSOR 1M50C
U104	5185765B26	IC PWR CTRL IN MOS20
U105	5185368C19	IC QUAD 10 BIT A/D CONV
U106	5185963A60	OP AMP IC
U2	5185353D14	IC SOT23-5 HI PRECISION REG 3V
U201	5186358E01	IC ANALOG OP-AMP CLC450
U202	5185963A27	IC TESTED AT25016 48 PIN GFP
U203	5185368C83	IC 12 BIT DAC
U3	5185353D14	IC SOT23-5 HI PRECISION REG 3V
U300	5105750U54	IC PKG DIE VCO BUFFER
U4	5105462G78	IC EEPROM 16K SPEI CMOS
U401	5185130C91	IC MIXER RF SOIC 10
U500	5185963A85	IC-ABACUS III-LP
VR1	4813830A33	DIODE 20V 5% 225MW MMBZ5250B_
VR2	4813830A15	DIODE 5.6V 5% 225MW MMBZ5232B_
W02	NOTPLACED	NOTPLACED
W021	NOTPLACED	NOTPLACED
W1	NOTPLACED	NOTPLACED
W10	NOTPLACED	NOTPLACED
W11	NOTPLACED	NOTPLACED
W12	NOTPLACED	NOTPLACED
W13	NOTPLACED	NOTPLACED
W14	NOTPLACED	NOTPLACED
W15	NOTPLACED	NOTPLACED
W16	NOTPLACED	NOTPLACED
W17	NOTPLACED	NOTPLACED
W18	NOTPLACED	NOTPLACED
W19	NOTPLACED	NOTPLACED

Ref. Des.	Part Number	Description
W2	NOTPLACED	NOTPLACED
W20	NOTPLACED	NOTPLACED
W21	NOTPLACED	NOTPLACED
W22	NOTPLACED	NOTPLACED
W23	NOTPLACED	NOTPLACED
W3	NOTPLACED	NOTPLACED
W4	NOTPLACED	NOTPLACED
W5	NOTPLACED	NOTPLACED
W6	NOTPLACED	NOTPLACED
W7	NOTPLACED	NOTPLACED
W8	NOTPLACED	NOTPLACED
W9	NOTPLACED	NOTPLACED
Y200	4802245J68	OSC REF 16.8 MHZ 1.5 PPM
Y301	4805911Z16	IND COAXIAL CERAMIC SMD
Y302	4805911Z17	IND COAXIAL CERAMIC SMD
Y303	4805911Z14	IND COAXIAL CERAMIC 1100 MHZ

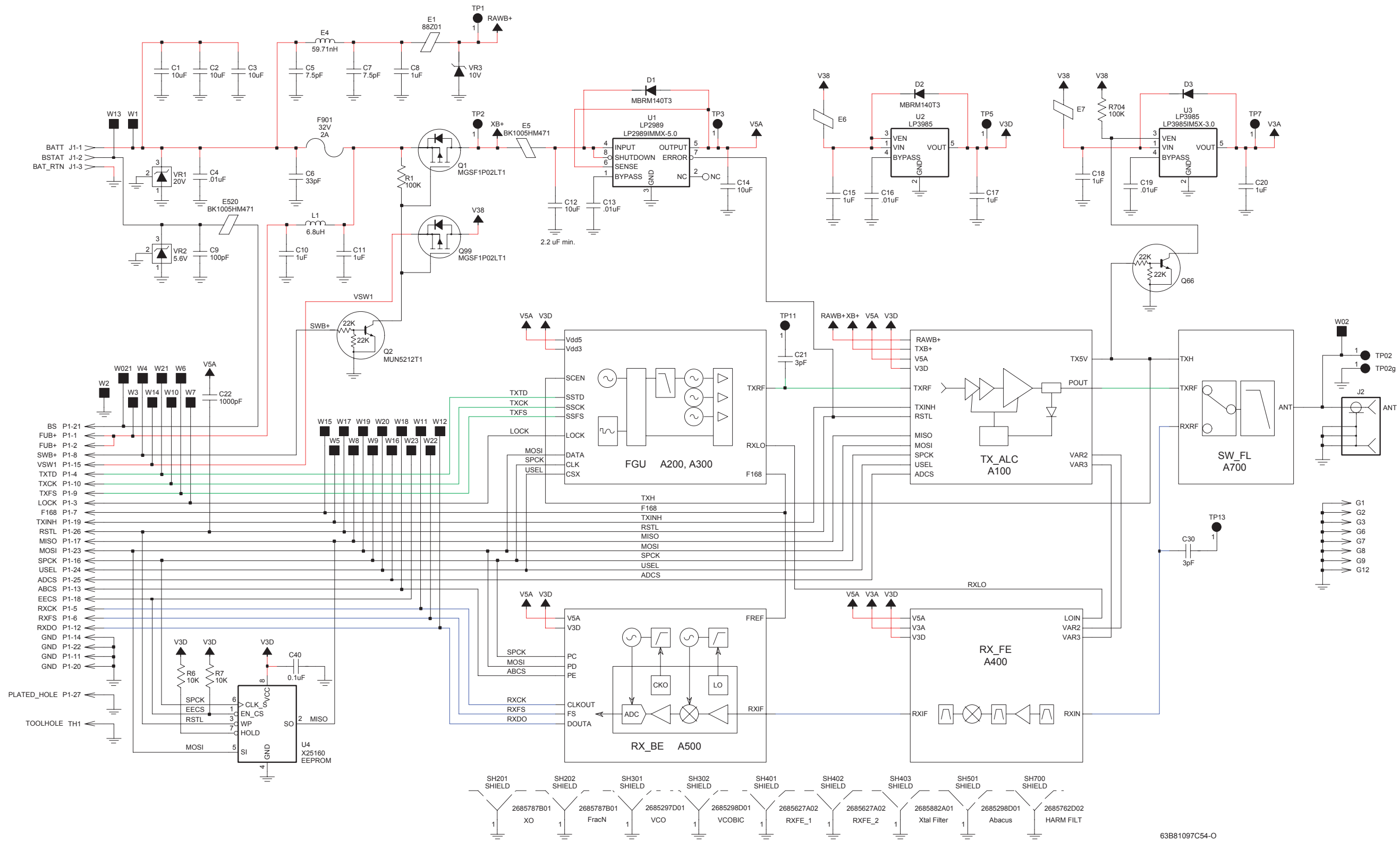
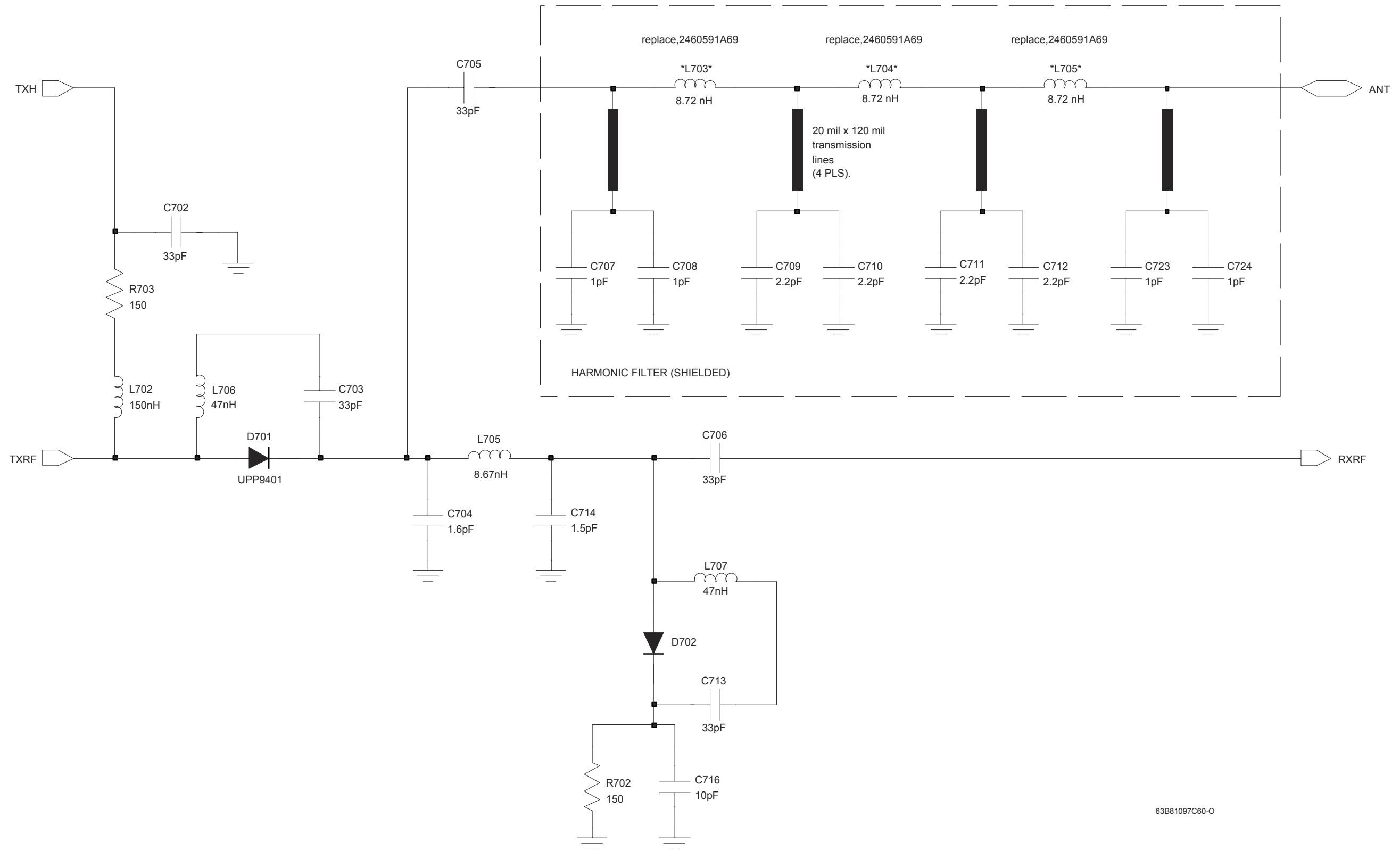

Figure 8-10. NUF3577C 700–800 MHz Transceiver (RF) Board Overall Circuit Schematic



63B81097C60-O

Figure 8-11. NUF3577C 700–800 MHz Antenna Switch and Harmonic Filter Circuits



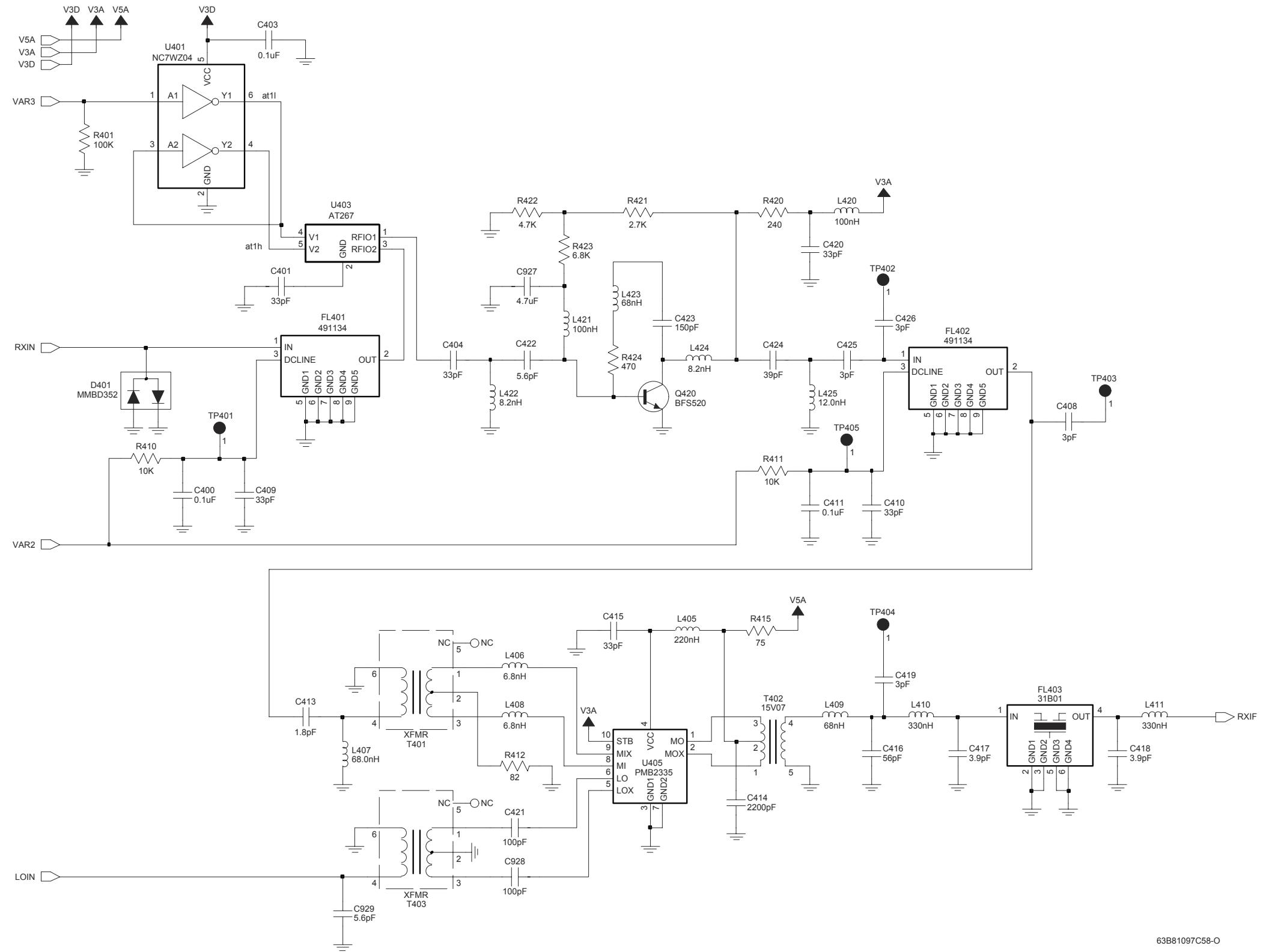

63B81097C58-O

Figure 8-12. NUF3577C 700–800 MHz Receiver Front End Circuit

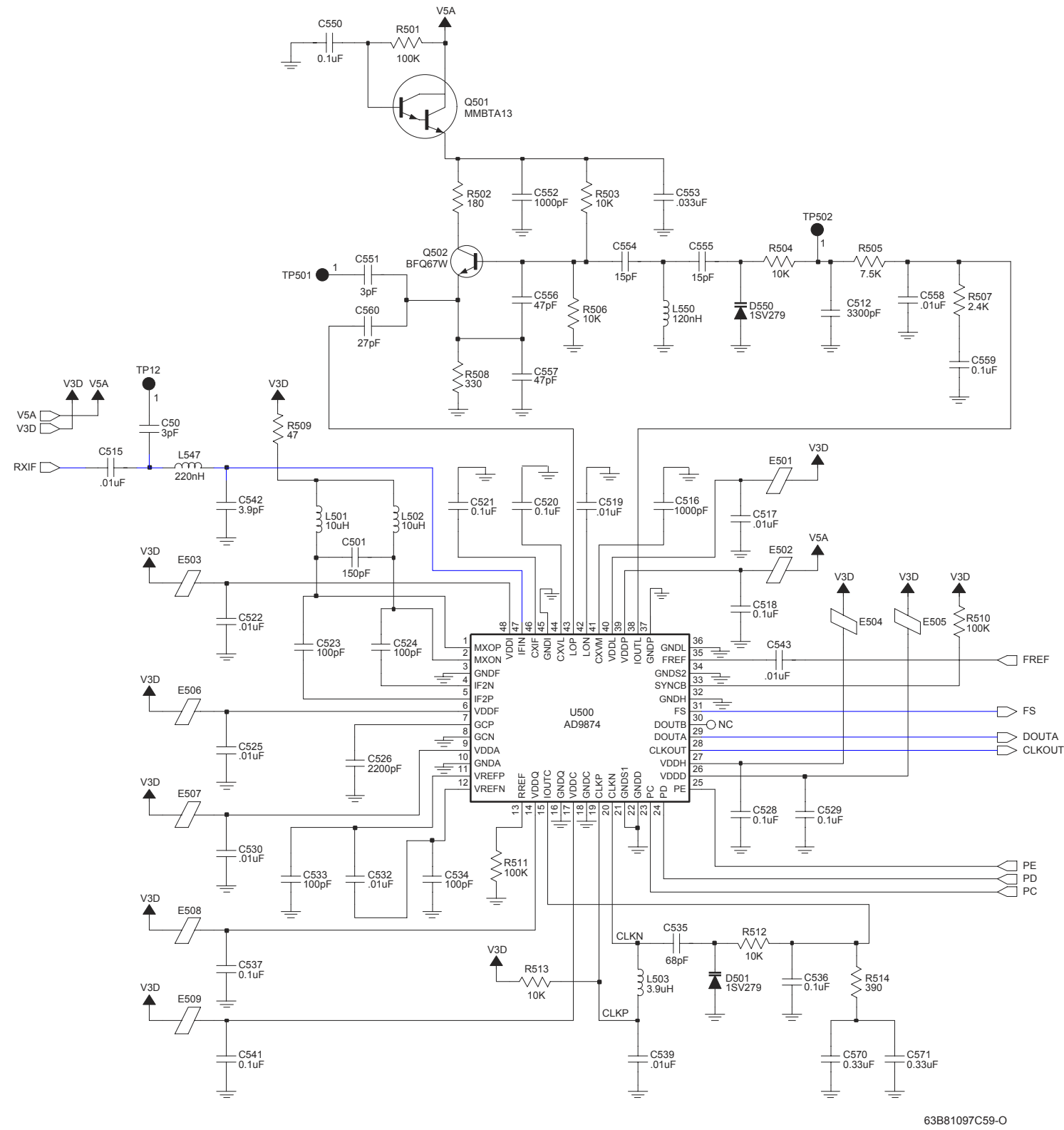

63B81097C59-O

Figure 8-13. NUF3577C 700–800 MHz Receiver Back End Circuit

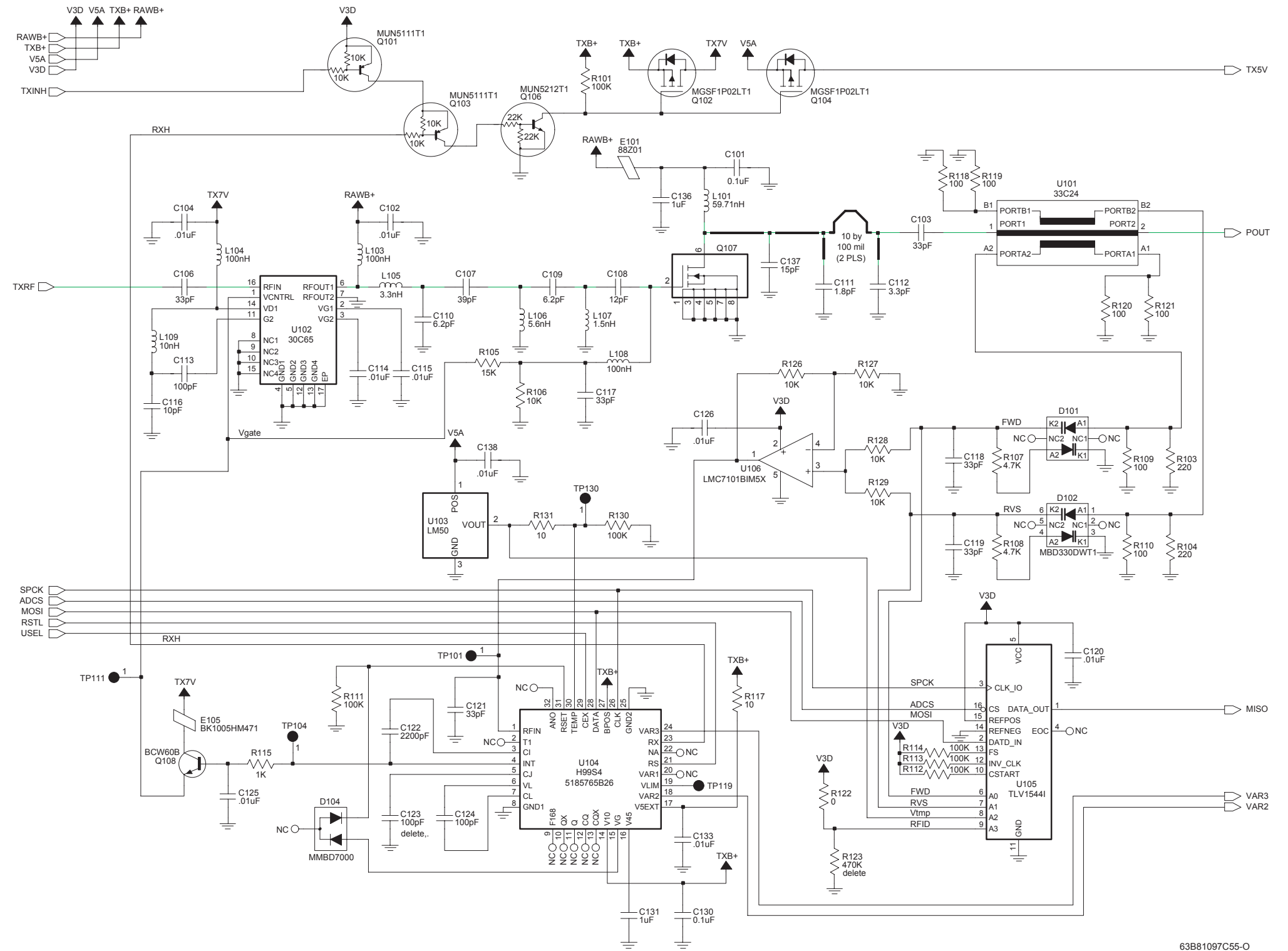

63B8109C55-O

Figure 8-14. NUF3577C 700–800 MHz Transmitter and Automatic Level Control Circuits

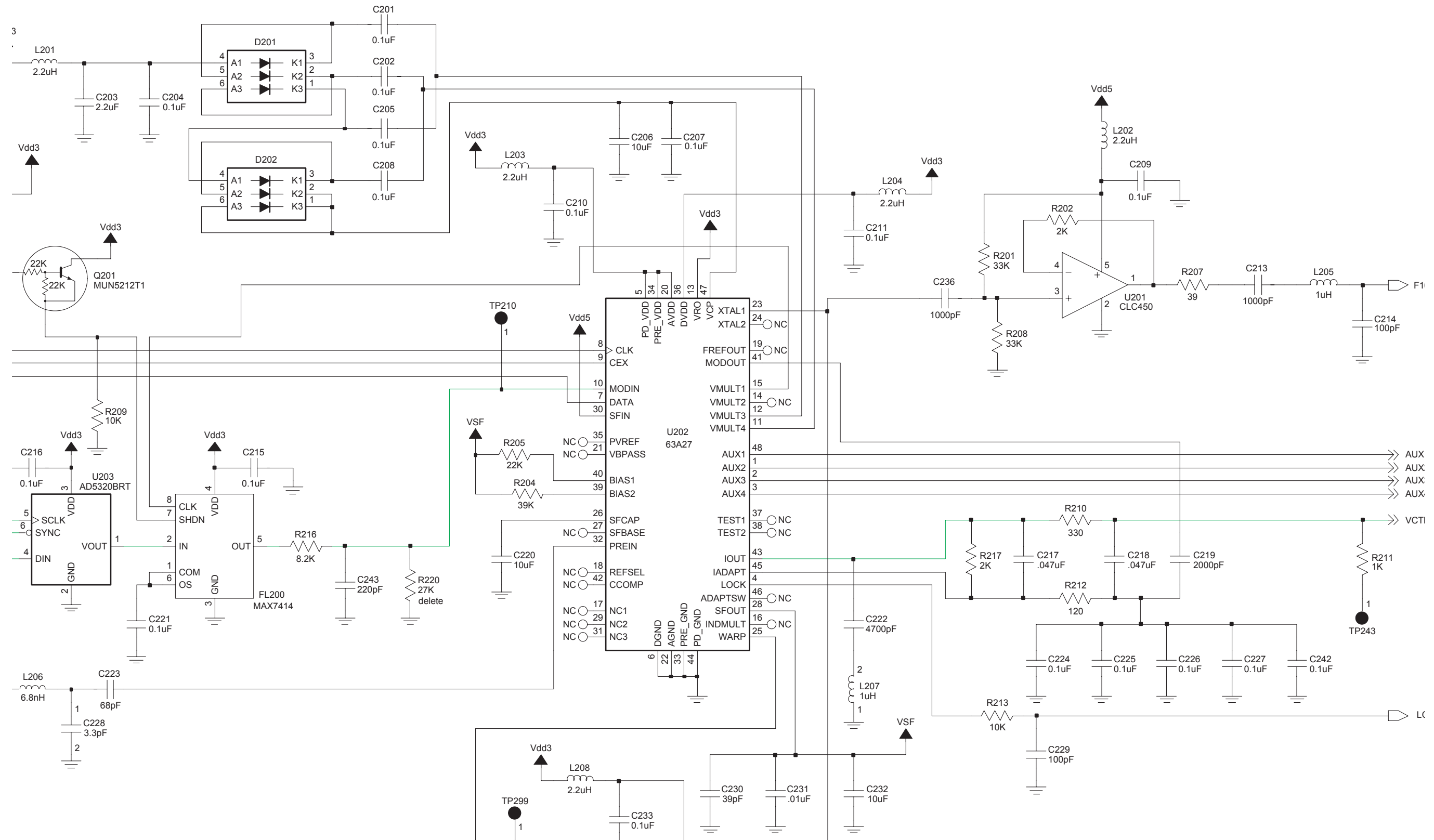
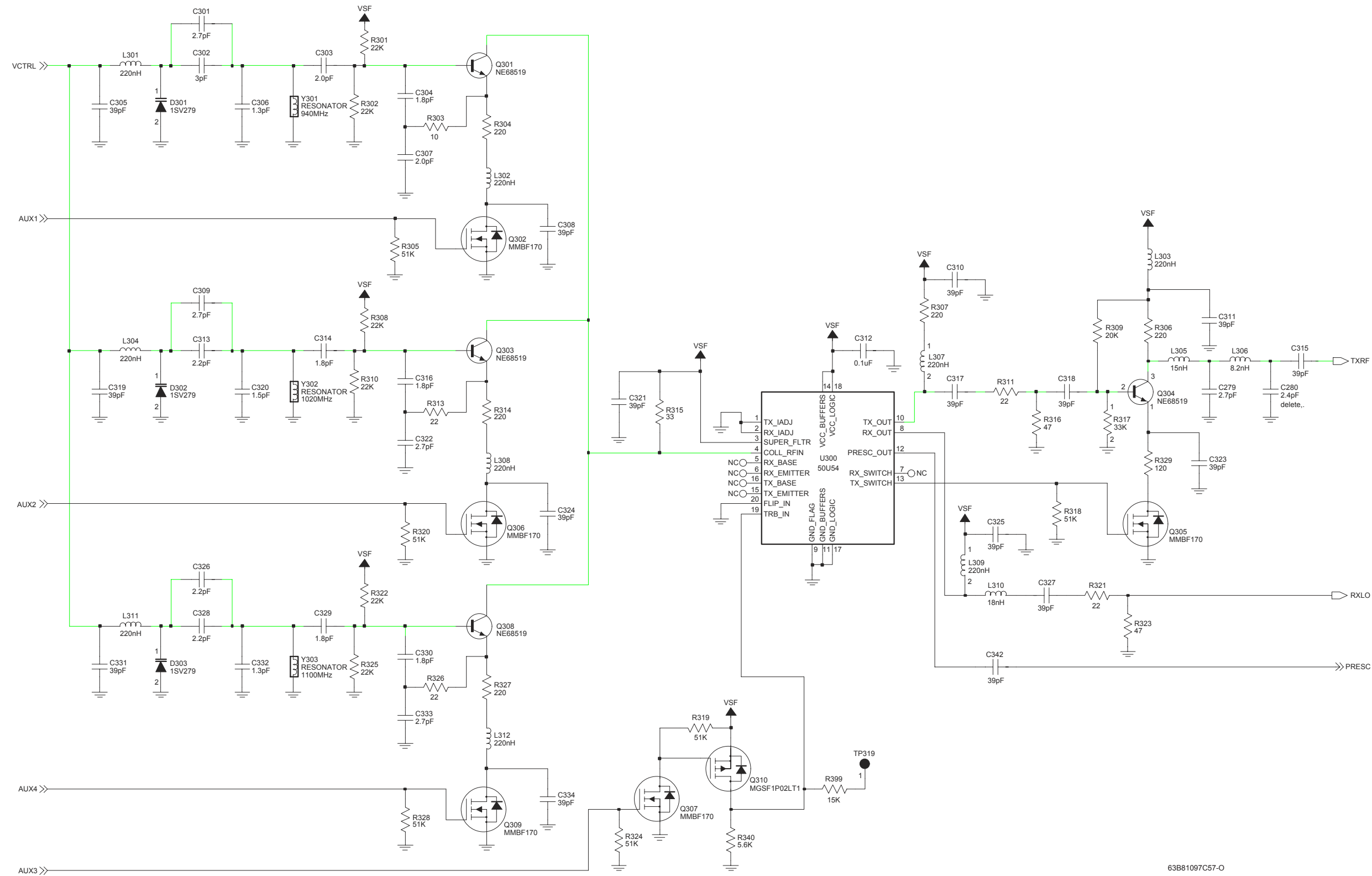
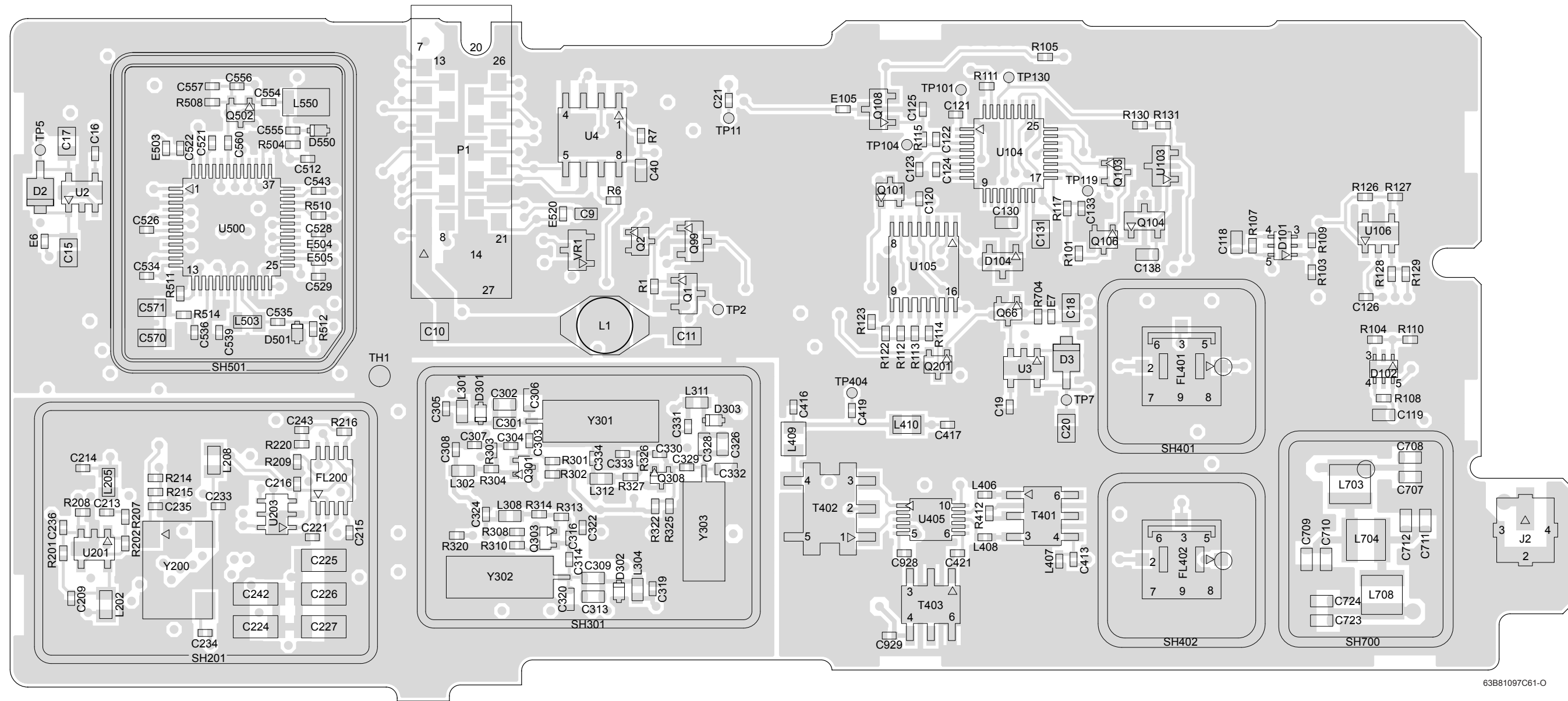

Figure 8-15. NUF3577C 700–800 MHz Frequency Generation Unit (Synthesizer) Circuit



63B81097C57-O

Figure 8-16. NUF3577C 700–800 MHz Frequency Generation Unit (VCO) Circuit



63B81097C61-O

Figure 8-17. NUF3577C 700–800 MHz Transceiver (RF) Board Layout—Side 1

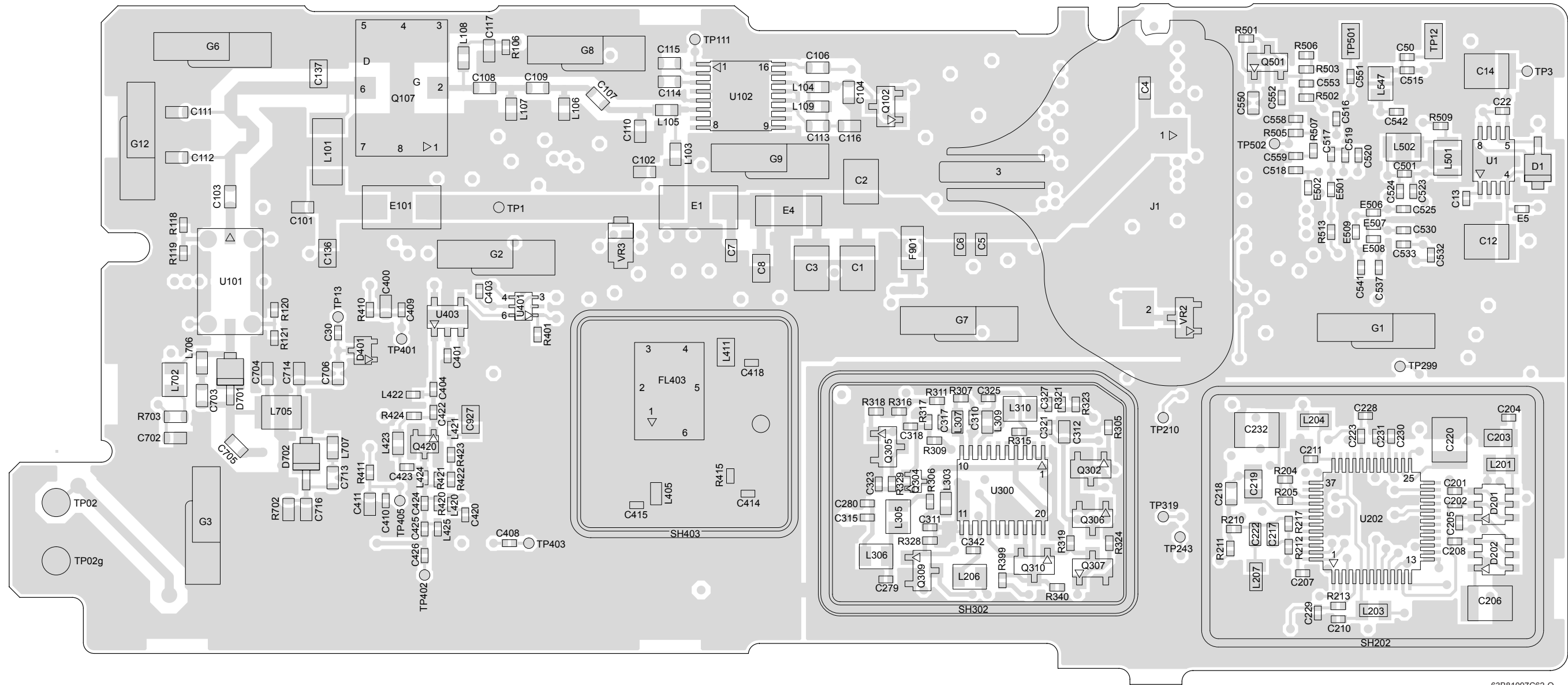

63B81097C62-O

Figure 8-18. NUF3577C 700–800 MHz Transceiver (RF) Board Layout—Side 2

**NUF3577C 700-800 MHz Transceiver (RF)  
Board Parts List**

Ref. Des.	Part Number	Description
C1	2113743T19	CAP 10UF 16V CER 3225 X5R
C10	2113743A31	CAP CHIP 1.0 UF 10% X7R
C101	2113743E20	CAP CHIP .10 UF 10%
C102	2113741F49	CAP CHIP CL2 X7R REEL 10000
C103	2113740F39	CAP CHIP REEL CL1 +/-30 33
C104	2113741F49	CAP CHIP CL2 X7R REEL 10000
C106	2113740F39	CAP CHIP REEL CL1 +/-30 33
C107	2113740F41	CAP CHIP REEL CL1 +/-30 39
C108	2113740F29	CAP CHIP REEL CL1 +/-30 12
C109	2113740F22	CAP CHIP REEL CL1 +/-30 6.2
C11	2113743A31	CAP CHIP 1.0 UF 10% X7R
C110	2113740F22	CAP CHIP REEL CL1 +/-30 6.2
C111	2113740F09	CAP CHIP REEL CL1 +/-30 1.8
C112	2113740F15	CAP CHIP REEL CL1 +/-30 3.3
C113	2113740F51	CAP CHIP REEL CL1 +/-30 100
C114	2113741F49	CAP CHIP CL2 X7R REEL 10000
C115	2113741F49	CAP CHIP CL2 X7R REEL 10000
C116	2113740F27	CAP CHIP REEL CL1 +/-30 10
C117	2113740F39	CAP CHIP REEL CL1 +/-30 33
C118	2113740F39	CAP CHIP REEL CL1 +/-30 33
C119	2113740F39	CAP CHIP REEL CL1 +/-30 33
C12	2113743T19	CAP 10UF 16V CER 3225 X5R
C120	2113743L41	CAP CHIP 10000 PF 10% X7R

Ref. Des.	Part Number	Description
C121	2113743N38	CAP CHIP 33.0 PF 5% COG
C122	2113743L25	CAP CHIP 2200 PF 10% X7R
C123	NOTPLACED	64AM DUMMY PART NUMBER
C124	2113743N50	CAP CHIP 100 PF 5% COG
C125	2113743L41	CAP CHIP 10000 PF 10% X7R
C126	2113743L41	CAP CHIP 10000 PF 10% X7R
C13	2113743L41	CAP CHIP 10000 PF 10% X7R
C130	2113743E20	CAP CHIP .10 UF 10%
C131	2113743A31	CAP CHIP 1.0 UF 10% X7R
C133	2113743L41	CAP CHIP 10000 PF 10% X7R
C136	2113743A31	CAP CHIP 1.0 UF 10% X7R
C137	2113742H43	CAP 15.0 PF 5%
C138	2113741F49	CAP CHIP CL2 X7R REEL 10000
C14	2113743T19	CAP 10UF 16V CER 3225 X5R
C15	2113743A31	CAP CHIP 1.0 UF 10% X7R
C16	2113743L41	CAP CHIP 10000 PF 10% X7R
C17	2113743A31	CAP CHIP 1.0 UF 10% X7R
C18	2113743A31	CAP CHIP 1.0 UF 10% X7R
C19	2113743L41	CAP CHIP 10000 PF 10% X7R
C2	2113743T19	CAP 10UF 16V CER 3225 X5R
C20	2113743A31	CAP CHIP 1.0 UF 10% X7R
C201	2113743M24	CAP CHIP 100000 PF +80-20% Y5V
C202	2113743M24	CAP CHIP 100000 PF +80-20% Y5V
C203	2113743F18	CAP CHIP 2.2 UF 16V +80-20%
C204	2113743M24	CAP CHIP 100000 PF +80-20% Y5V
C205	2113743M24	CAP CHIP 100000 PF +80-20% Y5V
C206	2113743T19	CAP 10UF 16V CER 3225 X5R

Ref. Des.	Part Number	Description
C207	2113743M24	CAP CHIP 100000 PF +80-20% Y5V
C208	2113743M24	CAP CHIP 100000 PF +80-20% Y5V
C209	2113743M24	CAP CHIP 100000 PF +80-20% Y5V
C21	2113743N13	CAP CHIP 3.0 PF +/-25PF COG
C210	2113743M24	CAP CHIP 100000 PF +80-20% Y5V
C211	2113743M24	CAP CHIP 100000 PF +80-20% Y5V
C213	2113743L17	CAP CHIP 1000 PF 10% X7R
C214	2113743N50	CAP CHIP 100 PF 5% COG
C215	2113743M24	CAP CHIP 100000 PF +80-20% Y5V
C216	2113743M24	CAP CHIP 100000 PF +80-20% Y5V
C217	2113743E12	CAP CHIP .047 UF 10% X7R
C218	2113743E12	CAP CHIP .047 UF 10% X7R
C219	2109720D20	CAP CHIP LOW DIST 2000 SOV
C22	2113743L17	CAP CHIP 1000 PF 10% X7R
C220	2113743T19	CAP 10UF 16V CER 3225 X5R
C221	2113743M24	CAP CHIP 100000 PF +80-20% Y5V
C222	2113741F41	CAP CHIP CL2 X7R REEL 4700
C223	2113743N46	QAP CHIP 68.0 PF 5% COG
C224	2109720D14	CAP CER CHIP LOW DIST .1 UF
C225	2109720D14	CAP CER CHIP LOW DIST .1 UF
C226	2109720D14	CAP CER CHIP LOW DIST .1 UF
C227	2109720D14	CAP CER CHIP LOW DIST .1 UF
C228	2113743Q14	CAP CHIP 3.3 PF +/-1PF 20*40
C229	2113743N50	CAP CHIP 100 PF 5% COG

Ref. Des.	Part Number	Description
C230	2113743N40	CAP CHIP 39.0 PF 5% COG
C231	2113743L41	CAP CHIP 10000 PF 10% X7R
C232	2113743T19	CAP 10UF 16V CER 3225 X5R
C233	2113743M24	CAP CHIP 100000 PF +80-20% Y5V
C234	2113743L41	CAP CHIP 10000 PF 10% X7R
C235	2113743N50	CAP CHIP 100 PF 5% COG
C236	2113743L17	CAP CHIP 1000 PF 10% X7R
C242	2109720D14	CAP CER CHIP LOW DIST .1 UF
C243	2113743L01	CAP CHIP 220 PF 10% X7R
C279	2113743N12	CAP CHIP 2.7 PF +/-25PF COG
C280	NOTPLACED	64AM DUMMY PART NUMBER
C3	2113743T19	CAP 10UF 16V CER 3225 X5R
C30	2113743N13	CAP CHIP 3.0 PF +/-25PF COG
C301	2113740L04	CAP CER CHIP 2.7 PF +/-0.1PF
C302	2113740L05	CAP CER CHIP 3.0 PF +/-0.1PF
C303	2104801Z13	CAP CER NPO 2.0PF 16V 1005 SMD
C304	2104801Z12	CAP CER NPO 1.8PF 16V 1005 SMD
C305	2113743N40	CAP CHIP 39.0 PF 5% COG
C306	2113740F06	CAP CHIP REEL CL1 +/-30 1.3
C307	2104801Z13	CAP CER NPO 2.0PF 16V 1005 SMD
C308	2113743N40	CAP CHIP 39.0 PF 5% COG
C309	2113740L04	CAP CER CHIP 2.7 PF +/-0.1PF
C310	2113743N40	CAP CHIP 39.0 PF 5% COG
C311	2113743N40	CAP CHIP 39.0 PF 5% COG
C312	2113743E20	CAP CHIP .10 UF 10%
C313	2113740L02	CAP CER CHIP 2.2 PF +/-0.1PF



Ref. Des.	Part Number	Description
C314	2104801Z12	CAP CER NPO 1.8PF 16V 1005 SMD
C315	2113743N40	CAP CHIP 39.0 PF 5% COG
C316	2104801Z12	CAP CER NPO 1.8PF 16V 1005 SMD
C317	2113743N40	CAP CHIP 39.0 PF 5% COG
C318	2113743N40	CAP CHIP 39.0 PF 5% COG
C319	2113743N40	CAP CHIP 39.0 PF 5% COG
C320	2113740F07	CAP CHIP REEL CL1 +/-30 1.5
C321	2113743N40	CAP CHIP 39.0 PF 5% COG
C322	2104801Z16	CAP CER NPO 2.7PF 16V 1005 SMD
C323	2113743N40	CAP CHIP 39.0 PF 5% COG
C324	2113743N40	CAP CHIP 39.0 PF 5% COG
C325	2113743N40	CAP CHIP 39.0 PF 5% COG
C326	2113740L02	CAP CER CHIP 2.2 PF +/- 0.1PF
C327	2113743N40	CAP CHIP 39.0 PF 5% COG
C328	2113740L02	CAP CER CHIP 2.2 PF +/- 0.1PF
C329	2104801Z12	CAP CER NPO 1.8PF 16V 1005 SMD
C330	2104801Z12	CAP CER NPO 1.8PF 16V 1005 SMD
C331	2113743N40	CAP CHIP 39.0 PF 5% COG
C332	2113740F06	CAP CHIP REEL CL1 +/-30 1.3
C333	2104801Z16	CAP CER NPO 2.7PF 16V 1005 SMD
C334	2113743N40	CAP CHIP 39.0 PF 5% COG
C342	2113743N40	CAP CHIP 39.0 PF 5% COG
C4	2113741F49	CAP CHIP CL2 X7R REEL 10000
C40	2113743E20	CAP CHIP .10 UF 10%
C400	2113743E20	CAP CHIP .10 UF 10%
C401	2113743N38	CAP CHIP 33.0 PF 5% COG
C403	2113928N01	CAP CER CHIP 0.1UF 10% 6.3
C404	2113743N38	CAP CHIP 33.0 PF 5% COG
C408	2113743N13	CAP CHIP 3.0 PF +/- .25PF COG
C409	2113743N38	CAP CHIP 33.0 PF 5% COG

Ref. Des.	Part Number	Description
C410	2113743N38	CAP CHIP 33.0 PF 5% COG
C411	2113743E20	CAP CHIP .10 UF 10%
C413	2104801Z12	CAP CER NPO 1.8PF 16V 1005 SMD
C414	2113743L25	CAP CHIP 2200 PF 10% X7R
C415	2113743N38	CAP CHIP 33.0 PF 5% COG
C416	2113743N44	CAP CHIP 56.0 PF 5% COG
C417	2113743N16	CAP CHIP 3.9 PF +/- .25PF COG
C418	2113743N16	CAP CHIP 3.9 PF +/- .25PF COG
C419	2113743N13	CAP CHIP 3.0 PF +/- .25PF COG
C420	2113743N38	CAP CHIP 33.0 PF 5% COG
C421	2113743N50	CAP CHIP 100 PF 5% COG
C422	2113743N20	CAP CHIP 5.6 PF +/- .5PF COG
C423	2113743N54	CAP CHIP 150 PF 5% COG
C424	2113743N40	CAP CHIP 39.0 PF 5% COG
C425	2113743N13	CAP CHIP 3.0 PF +/- .25PF COG
C426	2113743N13	CAP CHIP 3.0 PF +/- .25PF COG
C5	2113740F24	CAP CHIP REEL CL1 +/-30 7.5
C50	2113743N13	CAP CHIP 3.0 PF +/- .25PF COG
C501	2113743N54	CAP CHIP 150 PF 5% COG
C512	2113743L29	CAP CHIP 3300 PF 10% X7R
C515	2113743L41	CAP CHIP 10000 PF 10% X7R
C516	2113743L17	CAP CHIP 1000 PF 10% X7R
C517	2113743L41	CAP CHIP 10000 PF 10% X7R
C518	2113928N01	CAP CER CHIP 0.1UF 10% 6.3
C519	2113743L41	CAP CHIP 10000 PF 10% X7R
C520	2113928N01	CAP CER CHIP 0.1UF 10% 6.3

Ref. Des.	Part Number	Description
C521	2113928N01	CAP CER CHIP 0.1UF 10% 6.3
C522	2113743L41	CAP CHIP 10000 PF 10% X7R
C523	2113743N50	CAP CHIP 100 PF 5% COG
C524	2113743N50	CAP CHIP 100 PF 5% COG
C525	2113743L41	CAP CHIP 10000 PF 10% X7R
C526	2113743L25	CAP CHIP 2200 PF 10% X7R
C528	2113928N01	CAP CER CHIP 0.1UF 10% 6.3
C529	2113928N01	CAP CER CHIP 0.1UF 10% 6.3
C530	2113743L41	CAP CHIP 10000 PF 10% X7R
C532	2113743L41	CAP CHIP 10000 PF 10% X7R
C533	2113743N50	CAP CHIP 100 PF 5% COG
C534	2113743N50	CAP CHIP 100 PF 5% COG
C535	2113743N46	QAP CHIP 68.0 PF 5% COG
C536	2113928N01	CAP CER CHIP 0.1UF 10% 6.3
C537	2113928N01	CAP CER CHIP 0.1UF 10% 6.3
C539	2113743L41	CAP CHIP 10000 PF 10% X7R
C541	2113928N01	CAP CER CHIP 0.1UF 10% 6.3
C542	2113743N16	CAP CHIP 3.9 PF +/- .25PF COG
C543	2113743L41	CAP CHIP 10000 PF 10% X7R
C550	2113743E20	CAP CHIP .10 UF 10%
C551	2113743N13	CAP CHIP 3.0 PF +/- .25PF COG
C552	2113743L17	CAP CHIP 1000 PF 10% X7R
C553	2113743L50	CAP CHIP 33000 PF 10%
C554	2113743N30	CAP CHIP 15.0 PF 5% COG
C555	2113743N30	CAP CHIP 15.0 PF 5% COG
C556	2113743N42	CAP CHIP 47.0 PF 5% COG
C557	2113743N42	CAP CHIP 47.0 PF 5% COG

Ref. Des.	Part Number	Description
C558	2113743L41	CAP CHIP 10000 PF 10% X7R
C559	2113928N01	CAP CER CHIP 0.1UF 10% 6.3
C560	2113743N36	CAP CHIP 27.0 PF 5% COG
C570	2113743A24	CAP CHIP .330 UF 10% 16V
C571	2113743A24	CAP CHIP .330 UF 10% 16V
C6	2113740F39	CAP CHIP REEL CL1 +/-30 33
C7	2113740F24	CAP CHIP REEL CL1 +/-30 7.5
C702	2113740F39	CAP CHIP REEL CL1 +/-30 33
C703	2113740F39	CAP CHIP REEL CL1 +/-30 33
C704	2113740F08	CAP CHIP REEL CL1 +/-30 1.6
C705	2113740F39	CAP CHIP REEL CL1 +/-30 33
C706	2113740F39	CAP CHIP REEL CL1 +/-30 33
C707	2113740F03	CAP CHIP REEL CL1 +/-30 1.0
C708	2113740F03	CAP CHIP REEL CL1 +/-30 1.0
C709	2113740F11	CAP CHIP REEL CL1 +/-30 2.2
C710	2113740F11	CAP CHIP REEL CL1 +/-30 2.2
C711	2113740F11	CAP CHIP REEL CL1 +/-30 2.2
C712	2113740F11	CAP CHIP REEL CL1 +/-30 2.2
C713	2113740F39	CAP CHIP REEL CL1 +/-30 33
C714	2113740F07	CAP CHIP REEL CL1 +/-30 1.5
C716	2113740F27	CAP CHIP REEL CL1 +/-30 10
C723	2113740F03	CAP CHIP REEL CL1 +/-30 1.0
C724	2113740F03	CAP CHIP REEL CL1 +/-30 1.0
C8	2113743A31	CAP CHIP 1.0 UF 10% X7R

Ref. Des.	Part Number	Description
C9	2113740F51	CAP CHIP REEL CL1 +/-30 100
C927	2113928C04	CAP CER CHIP 4.7UF 6.3V10%0805
C928	2113743N50	CAP CHIP 100 PF 5% COG
C929	2113743N20	CAP CHIP 5.6 PF + -.5PF COG
D1	4813833A20	DIODE SCHOTTKY 1A 40V PWRMITE
D101	4802197J83	DUAL SHOTTKY DIODE MBD330DWT1
D102	4802197J83	DUAL SHOTTKY DIODE MBD330DWT1
D104	4805129M06	DIODE MMBD7000
D2	4813833A20	DIODE SCHOTTKY 1A 40V PWRMITE
D201	4802233J09	DIODE TRIPLE SOT25-RH
D202	4802233J09	DIODE TRIPLE SOT25-RH
D3	4813833A20	DIODE SCHOTTKY 1A 40V PWRMITE
D301	4809877C08	DIODE VARACTOR 1SV279 SMD
D302	4809877C08	DIODE VARACTOR 1SV279 SMD
D303	4809877C08	DIODE VARACTOR 1SV279 SMD
D401	4813825A19	DIODE SCHOTTKY BARRIER SERIES
D501	4809877C08	DIODE VARACTOR 1SV279 SMD
D550	4809877C08	DIODE VARACTOR 1SV279 SMD
D701	4805656W24	DIODE, PIN RF
D702	4805656W24	DIODE, PIN RF
E1	2405688Z01	INDUCTOR FERRITE BEAD
E101	2405688Z01	INDUCTOR FERRITE BEAD
E105	2480640Z01	SURFACE MOUNT FERRITE BEAD
E4	2460591K40	COIL AIR WOUND INDUC 59.71
E5	2480640Z01	SURFACE MOUNT FERRITE BEAD

Ref. Des.	Part Number	Description
E501	2480640Z01	SURFACE MOUNT FERRITE BEAD
E502	2480640Z01	SURFACE MOUNT FERRITE BEAD
E503	2480640Z01	SURFACE MOUNT FERRITE BEAD
E504	2480640Z01	SURFACE MOUNT FERRITE BEAD
E505	2480640Z01	SURFACE MOUNT FERRITE BEAD
E506	2480640Z01	SURFACE MOUNT FERRITE BEAD
E507	2480640Z01	SURFACE MOUNT FERRITE BEAD
E508	2480640Z01	SURFACE MOUNT FERRITE BEAD
E509	2480640Z01	SURFACE MOUNT FERRITE BEAD
E520	2480640Z01	SURFACE MOUNT FERRITE BEAD
E6	2480640Z01	SURFACE MOUNT FERRITE BEAD
E7	2480640Z01	SURFACE MOUNT FERRITE BEAD
F901	6505757V02	FUSE SURFACE MT 2AMP
FL200	9185130D01	FLTR SW CAP 3 POLE BUTTERW
FL401	9185004D01	LC FLTR, MULTILAYER CERAMIC
FL402	9185004D01	LC FLTR, MULTILAYER CERAMIC
FL403	4885631B01	XTAL FILT 3 POLE 109.65 MOTORO
G1	3905643V01	CONTACT ANT GRD
G12	3905643V01	CONTACT ANT GRD
G2	3905643V01	CONTACT ANT GRD
G3	3905643V01	CONTACT ANT GRD
G6	3905643V01	CONTACT ANT GRD
G7	3905643V01	CONTACT ANT GRD
G8	3905643V01	CONTACT ANT GRD
G9	3905643V01	CONTACT ANT GRD
J1	NOTPLACED	64AM DUMMY PART NUMBER
J2	0905304Z01	CONN COAXIAL SMT

Ref. Des.	Part Number	Description
L1	2486085A04	COIL, 6.8 UH POWER INDUCTOR
L101	2460591K40	COIL AIR WOUND INDUC 59.71
L103	2413926H24	IND CHIP 100 NH 5%
L104	2413926H24	IND CHIP 100 NH 5%
L105	2413926H06	IND CHIP 3.3 NH +/- 0.3NH
L106	2413926H09	IND CHIP 5.6 NH +/- 0.3NH
L107	2413926F02	IND 1.5 NH +/-0.3 NH
L108	2413926H24	IND CHIP 100 NH 5%
L109	2413926H12	CHIP INDUCTOR 10.0NH
L201	2462587Q20	IND CHIP 2,200 NH 20%
L202	2462587Q20	IND CHIP 2,200 NH 20%
L203	2462587Q20	IND CHIP 2,200 NH 20%
L204	2462587Q20	IND CHIP 2,200 NH 20%
L205	2462587Q47	IND CHIP 1,000 NH 10%
L206	2462587V21	CHIP IND 6.8 NH 5% 0805
L207	2462587Q47	IND CHIP 1,000 NH 10%
L208	2462587Q20	IND CHIP 2,200 NH 20%
L301	2409377M36	IND CHIP WW 220 NH 5% 1608
L302	2409377M36	IND CHIP WW 220 NH 5% 1608
L303	2409377M36	IND CHIP WW 220 NH 5% 1608
L304	2409377M36	IND CHIP WW 220 NH 5% 1608
L305	2462587V24	CHIP IND 15 NH 5% 0805
L306	2462587V22	CHIP IND 8.2 NH 5% 0805
L307	2409377M36	IND CHIP WW 220 NH 5% 1608
L308	2409377M36	IND CHIP WW 220 NH 5% 1608
L309	2409377M36	IND CHIP WW 220 NH 5% 1608
L310	2462587V25	CHIP IND 18 NH 5% 0805
L311	2409377M36	IND CHIP WW 220 NH 5% 1608
L312	2409377M36	IND CHIP WW 220 NH 5% 1608
L405	2409377M36	IND CHIP WW 220 NH 5% 1608

Ref. Des.	Part Number	Description
L406	2409154M11	IND MTLILYR 6.8NH 1005
L407	2409154M23	IND CER MLTILYR 68.0NH 1005
L408	2409154M11	IND MTLILYR 6.8NH 1005
L409	2462587V32	CHIP IND 68 NH 5% 0805
L410	2404574Z15	IND CHIP WW 330NH 2% 2012 SMD
L411	2404574Z15	IND CHIP WW 330NH 2% 2012 SMD
L420	2409154M48	IND CER MLTILYR 1.0NH 1005
L421	2409154M48	IND CER MLTILYR 1.0NH 1005
L422	2409154M12	IND MTLILYR 8.2NH 1005
L423	2409377M14	IND CHIP WW 68 NH 5% 1608
L424	2409154M12	IND MTLILYR 8.2NH 1005
L425	2409154M14	IND CER MLTILYR 12.0NH 1005
L501	2405769X05	COIL INDUCTOR
L502	2405769X05	COIL INDUCTOR
L503	2462587Q54	"IND CHIP 3,900 NH 10%"
L547	2462587V38	CHIP IND 220 NH 5% 0805
L550	2462587T16	IND CHIP 120NH 5% LOW PRO
L702	2462587V36	CHIP IND 150 NH 5% 0805
L703	2460591A69	COIL AIR WOUND INDUC 8.72
L704	2460591A69	COIL AIR WOUND INDUC 8.72
L705	2460591B22	COIL AIR WOUND INDUC 8.67
L706	2413926G15	IND 47.0 NH 5%
L707	2413926G15	IND 47.0 NH 5%
L708	2460591A69	COIL AIR WOUND INDUC 8.72
P1	NOTPLACED	64AM DUMMY PART NUMBER
PCB	8485013D02	PCB RF 800 MHZ
Q1	4813821A47	TSTR P-CH HDTMOS 20V
Q101	4813824A42	TSTR PNP 50V BIAS RES 10K 10K
Q102	4813821A47	TSTR P-CH HDTMOS 20V

Ref. Des.	Part Number	Description
Q103	4813824A42	TSTR PNP 50V BIAS RES 10K 10K
Q104	4813821A47	TSTR P-CH HDTMOS 20V
Q106	4813824A39	TSTR NPN 50V BIAS RES 22K 22K
Q107	5185633C10	MODE 800MHZ RING
Q108	4805128M12	TSTR SOT BCW 60B (RH)
Q2	4813824A39	TSTR NPN 50V BIAS RES 22K 22K
Q201	4813824A39	TSTR NPN 50V BIAS RES 22K 22K
Q301	4805793Y01	TRANS MINI SOT NPN LOW NOISE
Q302	4805218N11	XISTOR SOT RH BST82
Q303	4805793Y01	TRANS MINI SOT NPN LOW NOISE
Q304	4805793Y01	TRANS MINI SOT NPN LOW NOISE
Q305	4805218N11	XISTOR SOT RH BST82
Q306	4805218N11	XISTOR SOT RH BST82
Q307	4805218N11	XISTOR SOT RH BST82
Q308	4805793Y01	TRANS MINI SOT NPN LOW NOISE
Q309	4805218N11	XISTOR SOT RH BST82
Q310	4813821A47	TSTR P-CH HDTMOS 20V
Q420	4805585Q19	TRANSISTOR
Q501	4805128M19	TSTR SOT23 MMBTA13 RH
Q502	4805218N63	RF TRANS SOT 323 BFQ67W
Q66	4813824A39	TSTR NPN 50V BIAS RES 22K 22K
Q99	4813821A47	TSTR P-CH HDTMOS 20V
R1	0662057N23	RES. CHIP 100K 5% 20X40
R101	0662057N23	RES. CHIP 100K 5% 20X40
R103	0662057M58	RES. CHIP 220 5% 20X40
R104	0662057M58	RES. CHIP 220 5% 20X40
R105	0662057N03	RES. CHIP 15K 5% 20X40
R106	0662057M98	RES. CHIP 10K 5% 20X40
R107	0662057M90	RES. CHIP 4700 5% 20X40
R108	0662057M90	RES. CHIP 4700 5% 20X40
R109	0662057M50	RES. CHIP 100 5% 20X40
R110	0662057M50	RES. CHIP 100 5% 20X40

Ref. Des.	Part Number	Description
R111	0662057N23	RES. CHIP 100K 5% 20X40
R112	0662057N23	RES. CHIP 100K 5% 20X40
R113	0662057N23	RES. CHIP 100K 5% 20X40
R114	0662057N23	RES. CHIP 100K 5% 20X40
R115	0662057M74	RES. CHIP 1000 5% 20X40
R117	0662057M26	RES. CHIP 10 5% 20X40
R118	0662057M50	RES. CHIP 100 5% 20X40
R119	0662057M50	RES. CHIP 100 5% 20X40
R120	0662057M50	RES. CHIP 100 5% 20X40
R121	0662057M50	RES. CHIP 100 5% 20X40
R122	0662057M01	RES. CHIP 0 5% 20X40
R123	NOTPLACED	64AM DUMMY PART NUMBER
R126	0662057M98	RES. CHIP 10K 5% 20X40
R127	0662057M98	RES. CHIP 10K 5% 20X40
R128	0662057M98	RES. CHIP 10K 5% 20X40
R129	0662057M98	RES. CHIP 10K 5% 20X40
R130	0662057N23	RES. CHIP 100K 5% 20X40
R131	0662057M26	RES. CHIP 10 5% 20X40
R201	0662057N11	RES. CHIP 33K 5% 20X40
R202	0662057M81	RES. CHIP 2000 5% 20X40
R204	0662057N13	RES. CHIP 39K 5% 20X40
R205	0662057N07	RES. CHIP 22K 5% 20X40
R207	0662057M40	RES. CHIP 39 5% 20X40
R208	0662057N11	RES. CHIP 33K 5% 20X40
R209	0662057M98	RES. CHIP 10K 5% 20X40
R210	0662057M62	RES. CHIP 330 5% 20X40
R211	0662057M74	RES. CHIP 1000 5% 20X40
R212	0662057M52	RES. CHIP 120 5% 20X40
R213	0662057M98	RES. CHIP 10K 5% 20X40
R214	0662057M74	RES. CHIP 1000 5% 20X40
R215	0662057M98	RES. CHIP 10K 5% 20X40
R216	0662057M96	RES. CHIP 8200 5% 20X40
R217	0662057M81	RES. CHIP 2000 5% 20X40
R220	NOTPLACED	64AM DUMMY PART NUMBER
R301	0662057N07	RES. CHIP 22K 5% 20X40
R302	0662057N07	RES. CHIP 22K 5% 20X40
R303	0662057M26	RES. CHIP 10 5% 20X40

Ref. Des.	Part Number	Description
R304	0662057M58	RES. CHIP 220 5% 20X40
R305	0662057N16	RES. CHIP 51K 5% 20X40
R306	0662057M58	RES. CHIP 220 5% 20X40
R307	0662057M58	RES. CHIP 220 5% 20X40
R308	0662057N07	RES. CHIP 22K 5% 20X40
R309	0662057N06	RES. CHIP 20K 5% 20X40
R310	0662057N07	RES. CHIP 22K 5% 20X40
R311	0662057M34	RES. CHIP 22 5% 20X40
R313	0662057M34	RES. CHIP 22 5% 20X40
R314	0662057M58	RES. CHIP 220 5% 20X40
R315	0662057M38	RES. CHIP 33 5% 20X40
R316	0662057M42	RES. CHIP 47 5% 20X40
R317	0662057N11	RES. CHIP 33K 5% 20X40
R318	0662057N16	RES. CHIP 51K 5% 20X40
R319	0662057N16	RES. CHIP 51K 5% 20X40
R320	0662057N16	RES. CHIP 51K 5% 20X40
R321	0662057M34	RES. CHIP 22 5% 20X40
R322	0662057N07	RES. CHIP 22K 5% 20X40
R323	0662057M42	RES. CHIP 47 5% 20X40
R324	0662057N16	RES. CHIP 51K 5% 20X40
R325	0662057N07	RES. CHIP 22K 5% 20X40
R326	0662057M34	RES. CHIP 22 5% 20X40
R327	0662057M58	RES. CHIP 220 5% 20X40
R328	0662057N16	RES. CHIP 51K 5% 20X40
R329	0662057M52	RES. CHIP 120 5% 20X40
R340	0662057M92	RES. CHIP 5600 5% 20X40
R399	0662057N03	RES. CHIP 15K 5% 20X40
R401	0662057N23	RES. CHIP 100K 5% 20X40
R410	0662057M98	RES. CHIP 10K 5% 20X40
R411	0662057M98	RES. CHIP 10K 5% 20X40
R412	0662057M48	RES. CHIP 82 5% 20X40
R415	0662057M47	RES CHIP 75 5% 20X40
R420	0662057M59	RES CHIP 240 5% 20X40
R421	0662057M84	RES. CHIP 2700 5% 20X40
R422	0662057M90	RES. CHIP 4700 5% 20X40
R423	0662057M94	RES. CHIP 6800 5% 20X40
R424	0662057M66	RES. CHIP 470 5% 20X40
R501	0662057N23	RES. CHIP 100K 5% 20X40
R502	0662057M56	RES. CHIP 180 5% 20X40

Ref. Des.	Part Number	Description
R503	0662057M98	RES. CHIP 10K 5% 20X40
R504	0662057M98	RES. CHIP 10K 5% 20X40
R505	0662057M95	RES. CHIP 7500 5% 20X40
R506	0662057M98	RES. CHIP 10K 5% 20X40
R507	0662057M83	RES. CHIP 2400 5% 20X40
R508	0662057M62	RES. CHIP 330 5% 20X40
R509	0662057M42	RES. CHIP 47 5% 20X40
R510	0662057N23	RES. CHIP 100K 5% 20X40
R511	0662057N23	RES. CHIP 100K 5% 20X40
R512	0662057M98	RES. CHIP 10K 5% 20X40
R513	0662057M98	RES. CHIP 10K 5% 20X40
R514	0662057M64	RES. CHIP 390 5% 20X40
R6	0662057M98	RES. CHIP 10K 5% 20X40
R7	0662057M98	RES. CHIP 10K 5% 20X40
R702	0662057A29	CHIP RES 150 OHMS 5%
R703	0662057A29	CHIP RES 150 OHMS 5%
R704	0662057N23	RES. CHIP 100K 5% 20X40
SH201	2685787B01	SHLD FRAC-N
SH202	2685787B01	SHLD FRAC-N
SH301	2685297D01	SHLD VCO
SH302	2685298D01	SHLD VCO BUFFER
SH401	2685627A02	SHLD DUAL INDUCTOR
SH402	2685627A02	SHLD DUAL INDUCTOR
SH403	2685882A01	SHLD VCO TANK
SH501	2685298D01	SHLD VCO BUFFER
SH700	2685762D02	SHIELD HARMONIC FILTER
T401	2580541Z02	BALUN TRANSFORMER (NEW)
T402	2505515V07	XFMR JEDI MIXER 25:1
T403	2580541Z02	BALUN TRANSFORMER (NEW)
TH1	NOTPLACED	64AM DUMMY PART NUMBER
U1	5185353D13	IC MINI SO-8 HI PRECISION REG 5V
U101	5185633C24	MODULE DIRECT COUPLER
U102	5185130C65	IC VHF/UHF/800 MHZ LD MOS DRIVER

Ref. Des.	Part Number	Description
U103	5185963A15	IC TEMPERTURE SENSOR 1M50C
U104	5185765B26	IC PWR CTRL IN MOS20
U105	5185368C19	IC QUAD 10 BIT A/D CONV
U106	5185963A60	IC OP AMP
U2	5185353D14	IC SOT23-5 HI PRECISION REG 3V
U201	5186358E01	IC ANALOG OP-AMP CLC450
U202	5185963A27	IC TESTED AT25016 48 PIN GFP
U203	5185368C83	IC 12 BIT DAC
U3	5185353D14	IC SOT23-5 HI PRECISION REG 3V
U300	5105750U54	IC PKG DIE VCO BUFFER
U4	5105462G78	IC EEPROM 16K SPEI CMOS
U401	5185143E12	IC INVERTER DUAL SC70
U403	5185130C83	IC 15DB DIGITAL ATTEUATOR SOT25 PKG
U405	5185130C91	IC MIXER RF SOIC 10
U500	5185963A85	IC-ABACUS III-LP
VR1	4813830A33	DIODE 20V 5% 225MW MMBZ5250B_
VR2	4813830A15	DIODE 5.6V 5% 225MW MMBZ5232B_
VR3	4805656W45	DIODE TRANSIENT VOLTAGE SUPPRESSOR
W02	NOTPLACED	64AM DUMMY PART NUMBER
W021	NOTPLACED	64AM DUMMY PART NUMBER
W1	NOTPLACED	64AM DUMMY PART NUMBER
W10	NOTPLACED	64AM DUMMY PART NUMBER
W11	NOTPLACED	64AM DUMMY PART NUMBER
W12	NOTPLACED	64AM DUMMY PART NUMBER
W13	NOTPLACED	64AM DUMMY PART NUMBER
W14	NOTPLACED	64AM DUMMY PART NUMBER

Ref. Des.	Part Number	Description
W15	NOTPLACED	64AM DUMMY PART NUMBER
W16	NOTPLACED	64AM DUMMY PART NUMBER
W17	NOTPLACED	64AM DUMMY PART NUMBER
W18	NOTPLACED	64AM DUMMY PART NUMBER
W19	NOTPLACED	64AM DUMMY PART NUMBER
W2	NOTPLACED	64AM DUMMY PART NUMBER
W20	NOTPLACED	64AM DUMMY PART NUMBER
W21	NOTPLACED	64AM DUMMY PART NUMBER
W22	NOTPLACED	64AM DUMMY PART NUMBER
W23	NOTPLACED	64AM DUMMY PART NUMBER
W3	NOTPLACED	64AM DUMMY PART NUMBER
W4	NOTPLACED	64AM DUMMY PART NUMBER
W5	NOTPLACED	64AM DUMMY PART NUMBER
W6	NOTPLACED	64AM DUMMY PART NUMBER
W7	NOTPLACED	64AM DUMMY PART NUMBER
W8	NOTPLACED	64AM DUMMY PART NUMBER
W9	NOTPLACED	64AM DUMMY PART NUMBER
Y200	4802245J68	OSC, REF 16.8 MHZ 1.5 PPM
Y301	4805911Z16	IND COAXIAL CERAMIC SMD
Y302	4805911Z17	IND COAXIAL CERAMIC SMD
Y303	4805911Z14	IND COAXIAL CERAMIC 1100 MHZ

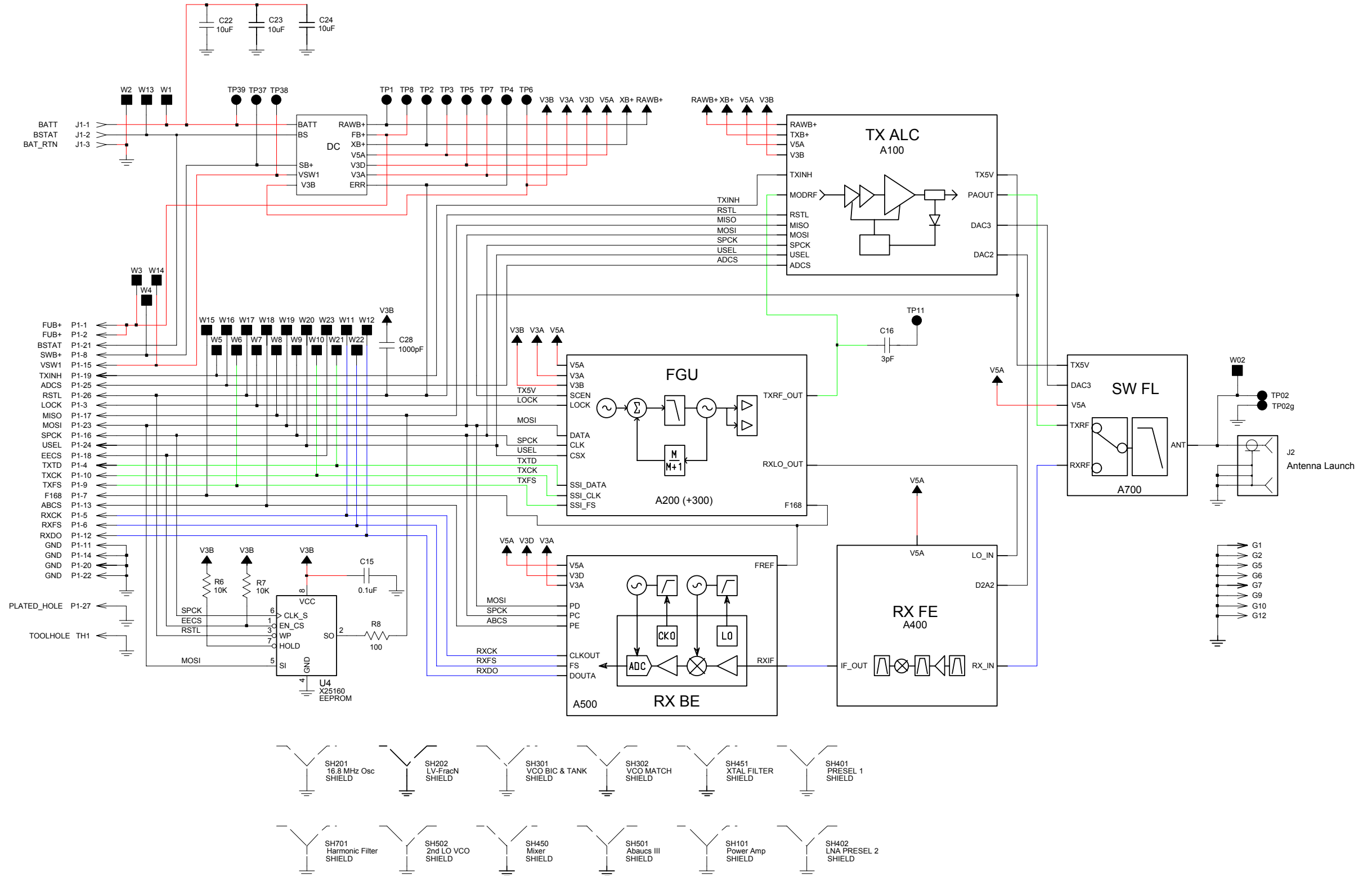

63B81096C57-O

Figure 8-19. NLD8910B VHF Transceiver (RF) Board Overall Circuit Schematic

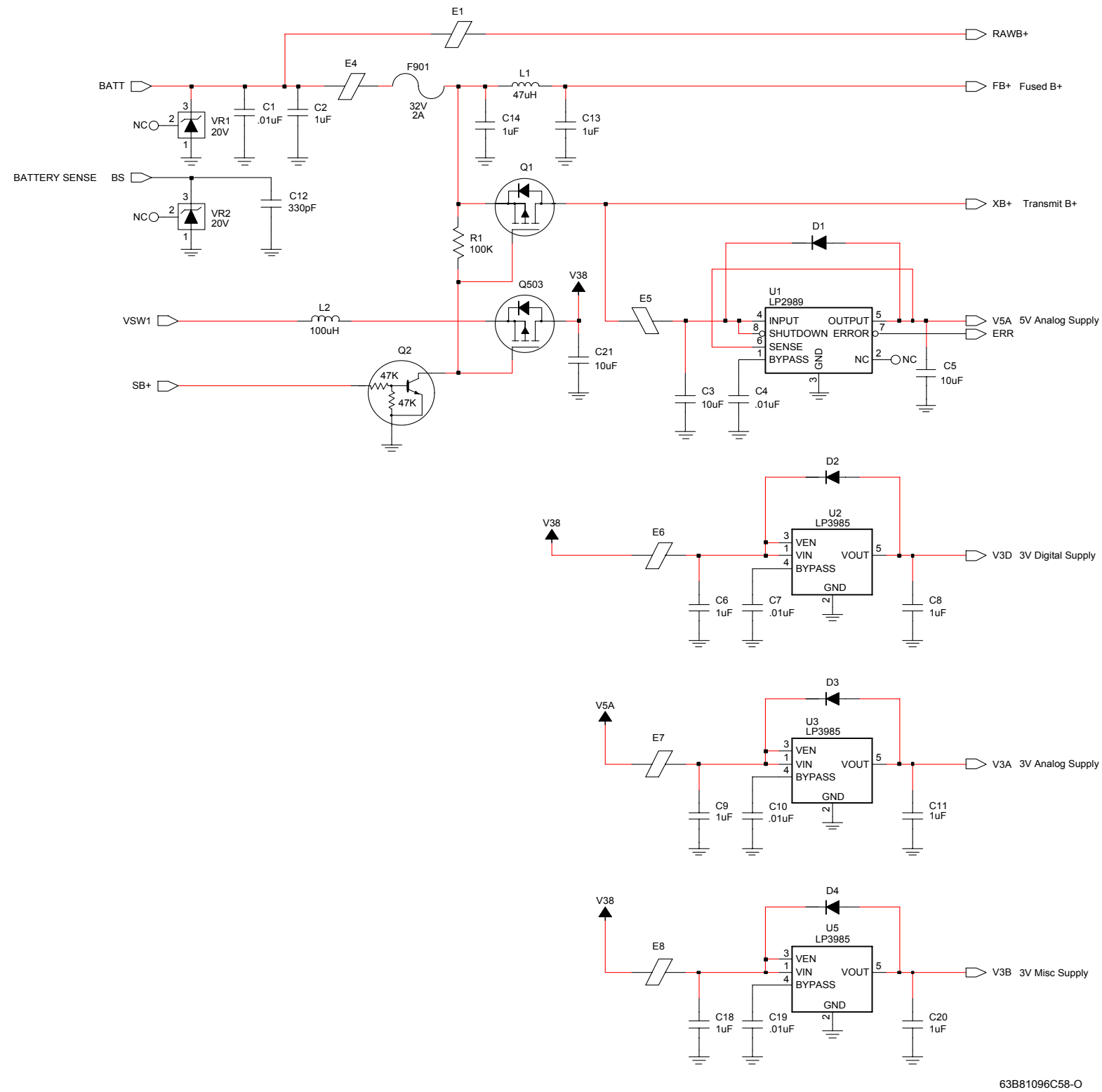

63B81096C58-O

Figure 8-20. NLD8910B VHF DC Power Circuits

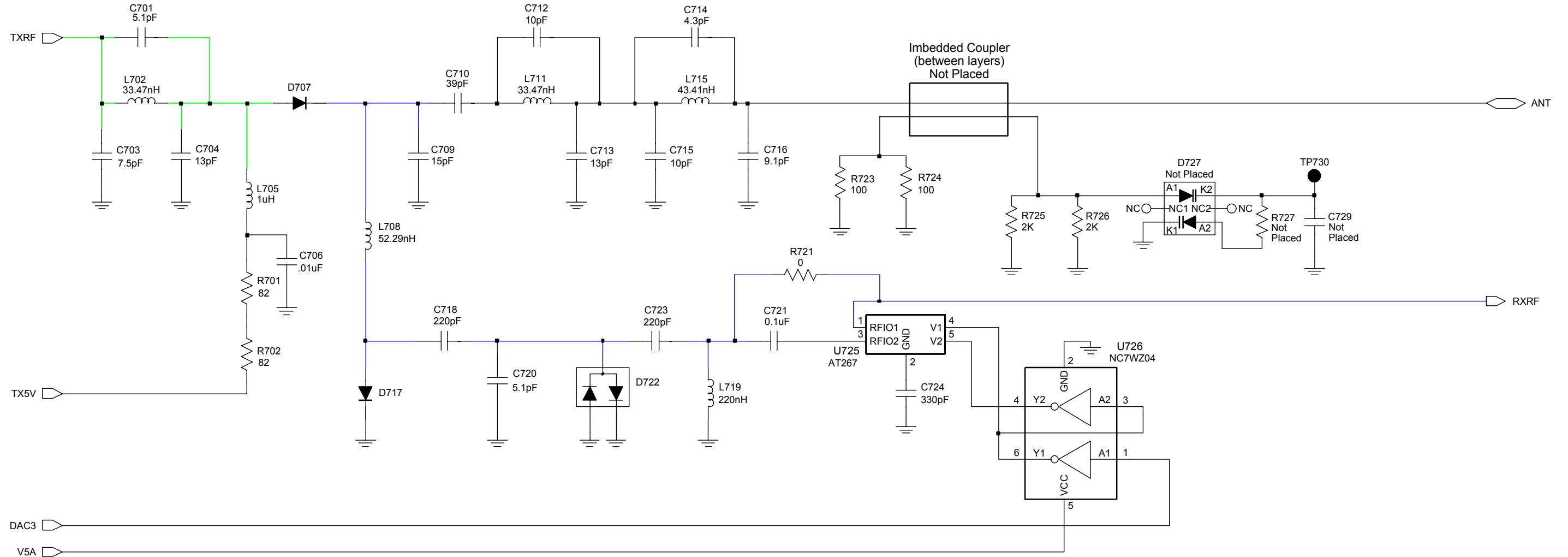

63B81096C65-O

Figure 8-21. NLD8910B VHF Antenna Switch and Harmonic Filter Circuits

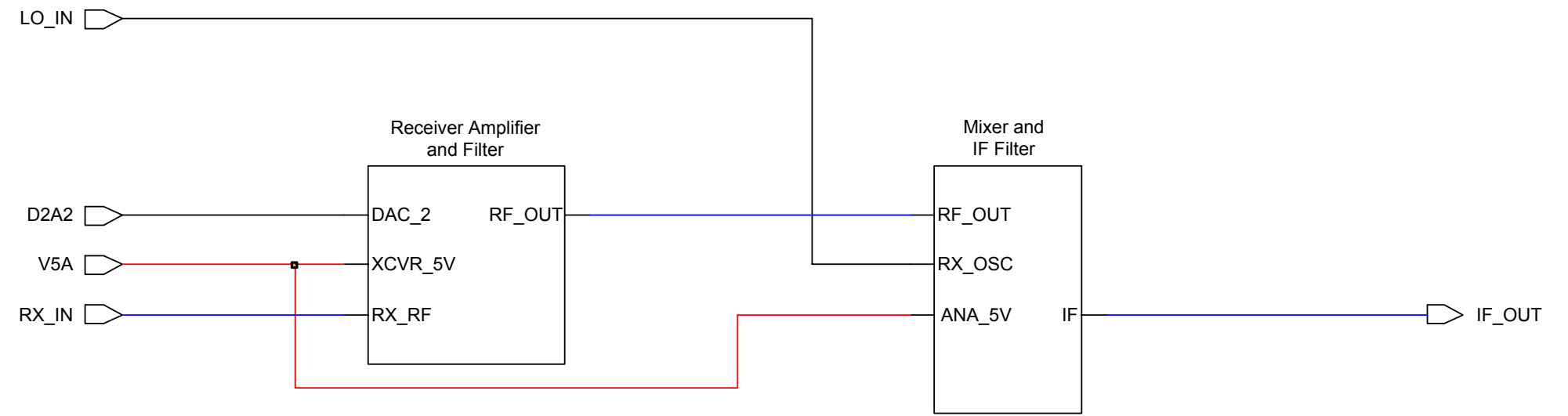

63B81096C63-O

Figure 8-22. NLD8910B VHF Receiver Front End Circuit



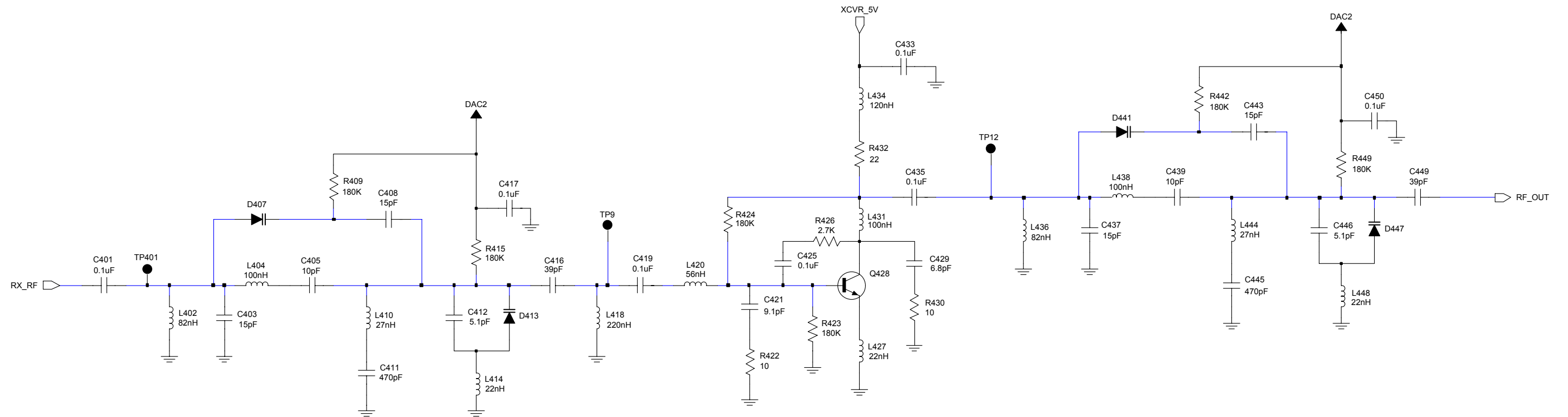

63B81096C62-O

Figure 8-23. NLD8910B VHF Receiver Amplifier and Filter Circuit

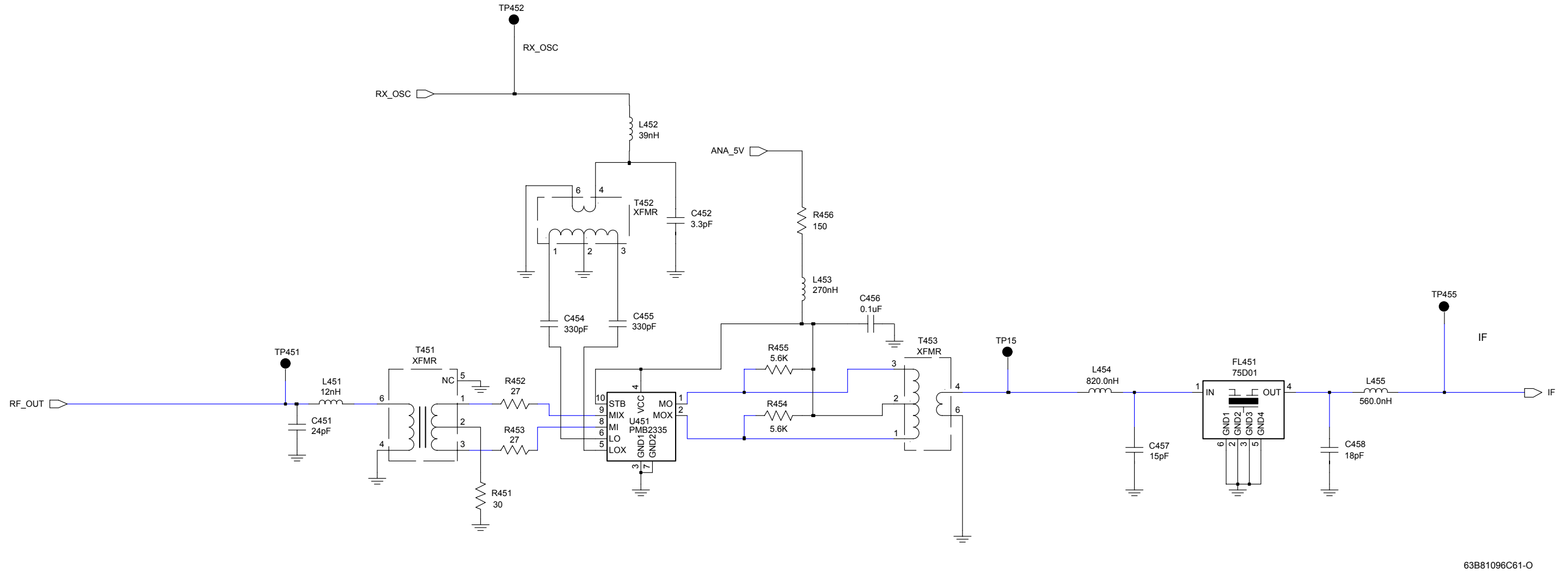

63B81096C61-O

Figure 8-24. NLD8910B VHF Mixer and IF Filter Circuits

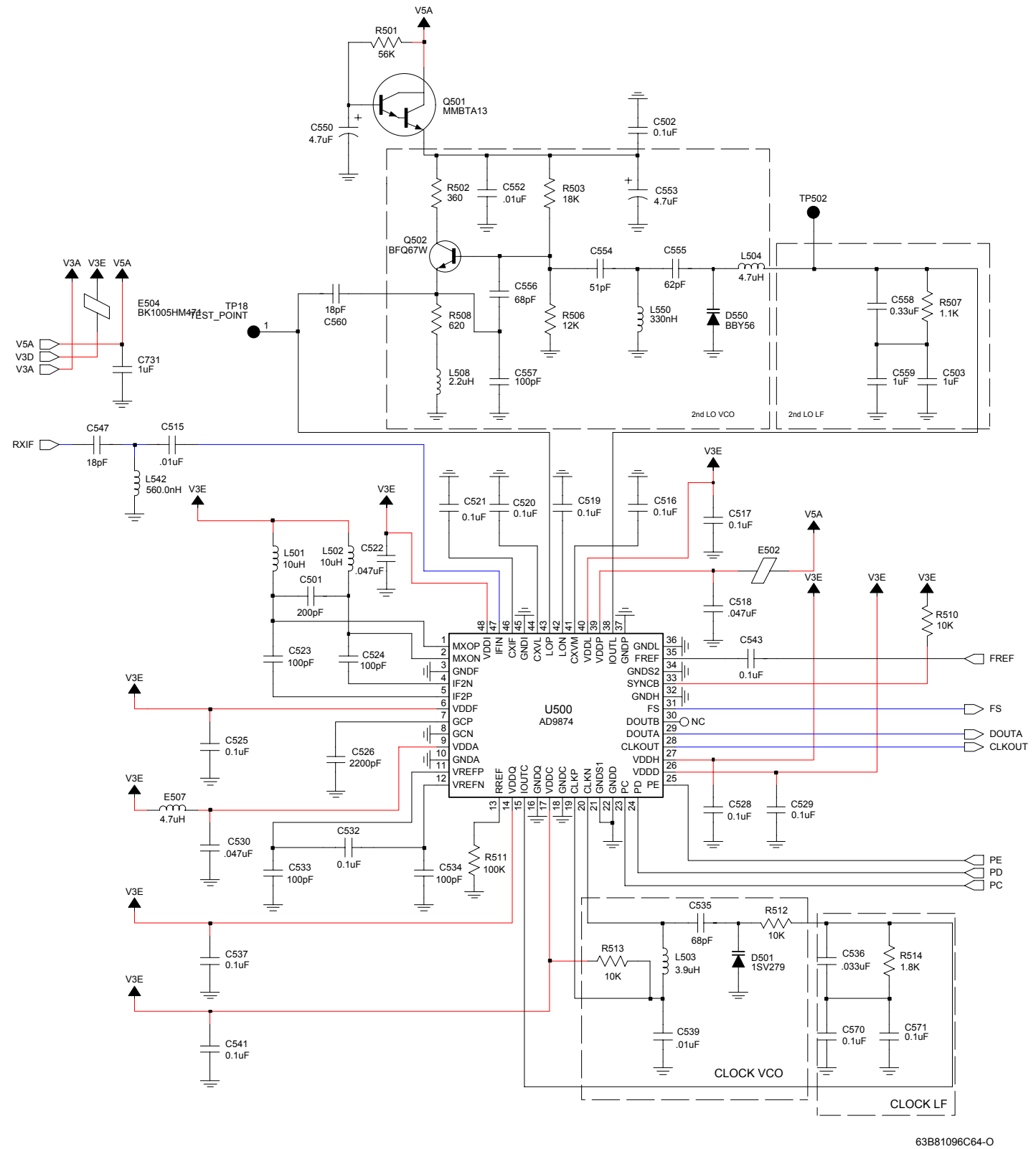
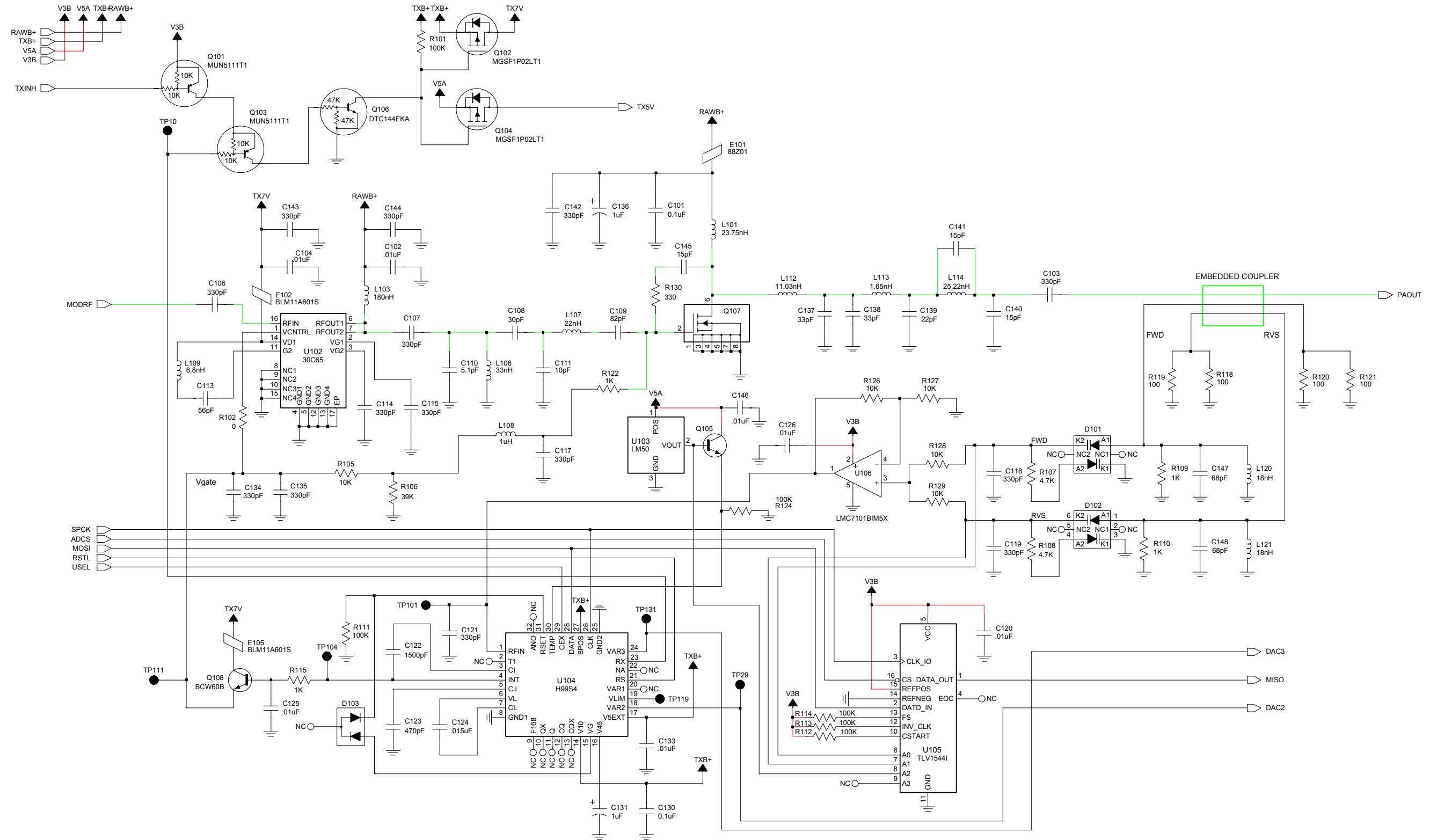
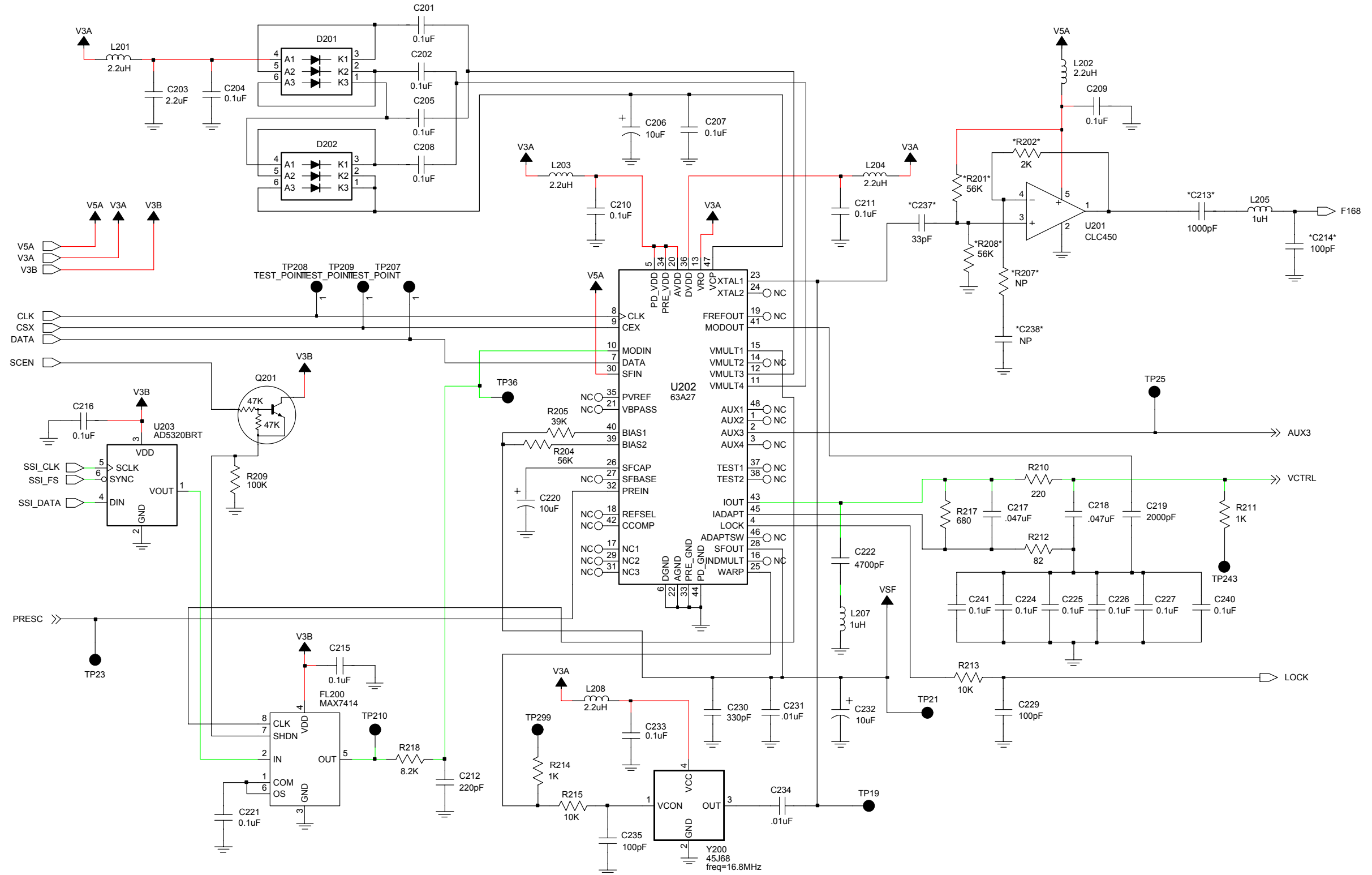

Figure 8-25. NLD8910B VHF Receiver Back End Circuit



63B81096C66-O

Figure 8-26. NLD8910B VHF Transmitter and Automatic Level Control Circuits



63B81096C59-O

Figure 8-27. NLD8910B VHF Frequency Generation Unit (Synthesizer) Circuit

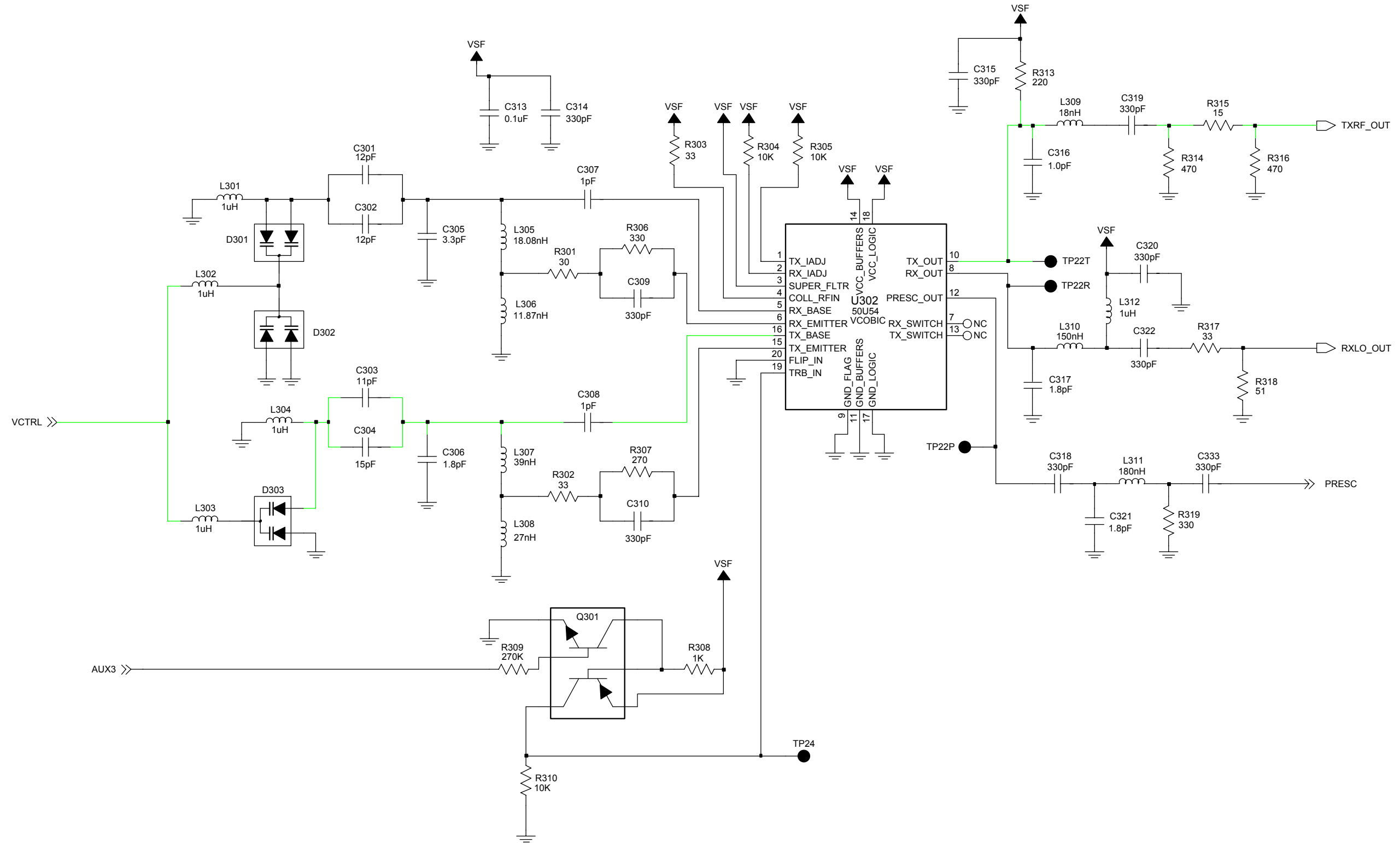

63B81096C60-O

Figure 8-28. NLD8910B VHF Frequency Generation Unit (VCO) Circuit

VIEWED FROM SIDE 1

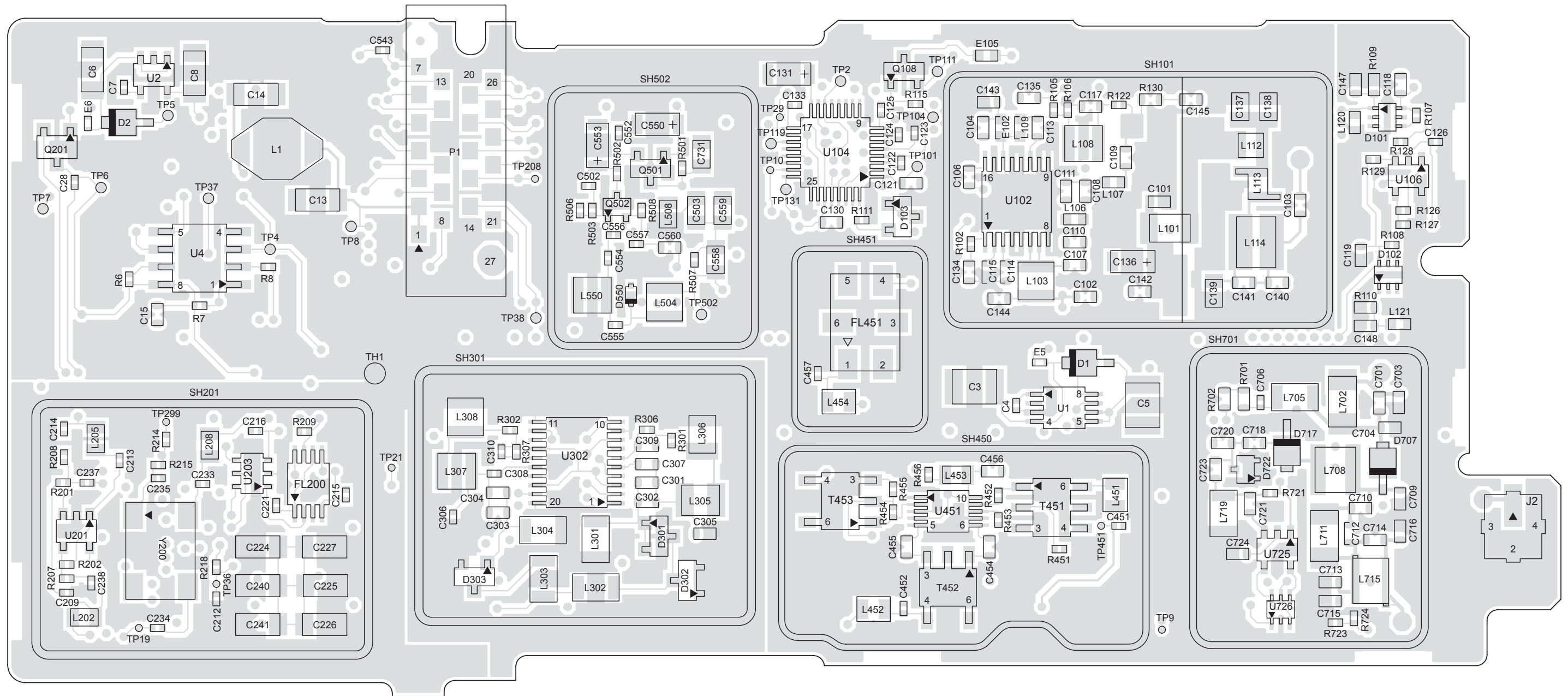

MAEPF-27525-O

Figure 8-29. NLD8910B VHF Transceiver (RF) Board Layout—Side 1

VIEWED FROM SIDE 2

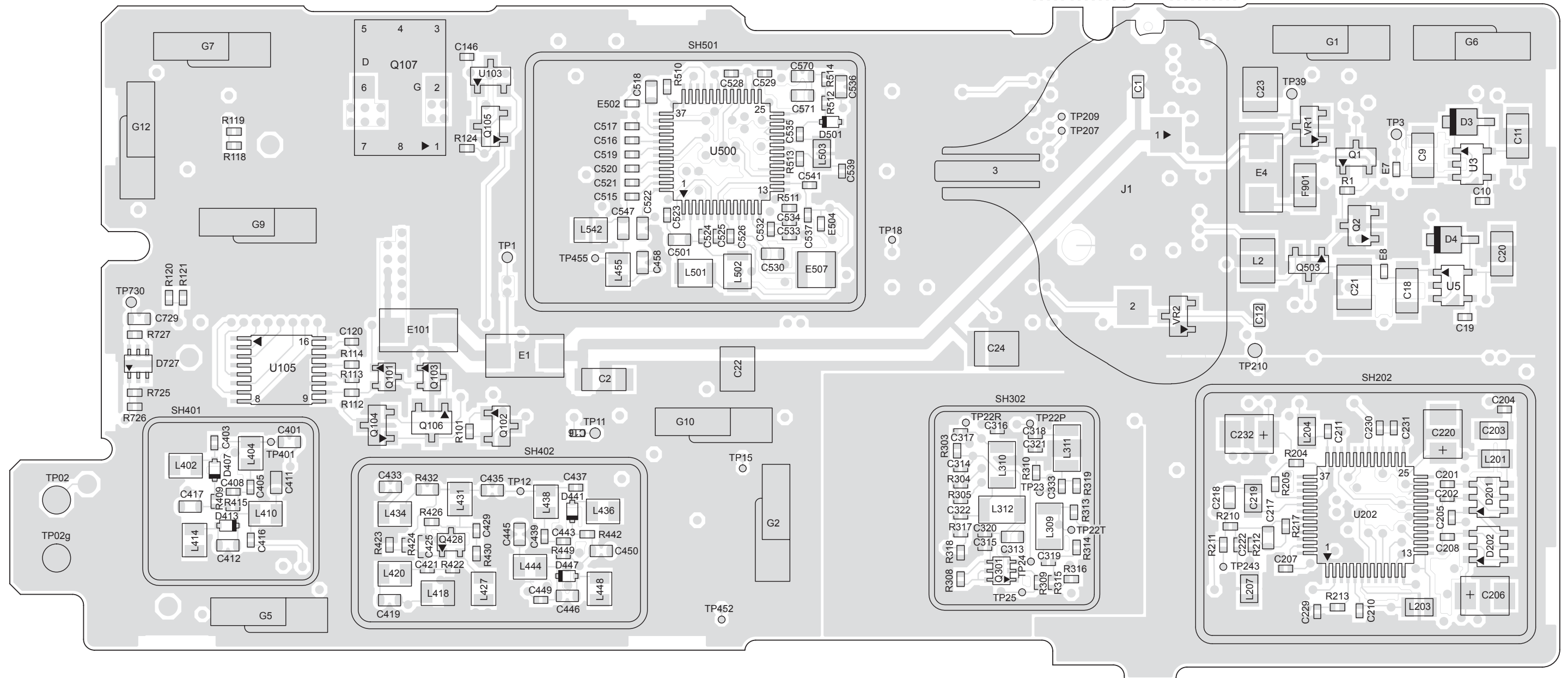

MAEPF-27526-O

Figure 8-30. NLD8910B VHF Transceiver (RF) Board Layout—Side 2



## NLD8910B VHF Transceiver (RF) Board Parts List

Ref. Des.	Part Number	Description
—	0005075C01	RF & VOCON BD TEST FOR XTS5000
—	1105033S02	RIBBON LABEL LT. PACK LABEL
—	1105033S13	RIBBON LBL
—	5405569Y02	LBL BARCODE APC
—	5405569Y03	LABEL BARCODE
—	5685647D01	UNI-BOARD CLAMSHELL
C1	2113741F49	CAP CHIP CL2 X7R REEL 10000
C10	2113743L41	CAP CHIP 10000 PF 10% X7R
C101	2113743E20	CAP CHIP .10 UF 10%
C102	2113741F49	CAP CHIP CL2 X7R REEL 10000
C103	2113740F63	CAP CHIP CL1 +/-30 330 5%
C104	2113741F49	CAP CHIP CL2 X7R REEL 10000
C106	2113740F63	CAP CHIP CL1 +/-30 330 5%
C107	2113740F63	CAP CHIP CL1 +/-30 330 5%
C108	2113740F38	CAP CHIP REEL CL1 +/-30 30
C109	2113740F49	CAP CHIP REEL CL1 +/-30 82
C11	2113743S01	CAP CER CHIP 1.0 UF 10% 16V
C110	2113740F20	CAP CHIP REEL CL1 +/-30 5.1
C111	2113740F27	CAP CHIP REEL CL1 +/-30 10
C113	2113740F45	CAP CHIP REEL CL1 +/-30 56
C114	2113740F63	CAP CHIP CL1 +/-30 330 5%

Ref. Des.	Part Number	Description
C115	2113740F63	CAP CHIP CL1 +/-30 330 5%
C117	2113740F63	CAP CHIP CL1 +/-30 330 5%
C118	2113740F63	CAP CHIP CL1 +/-30 330 5%
C119	2113740F63	CAP CHIP CL1 +/-30 330 5%
C12	2113740F63	CAP CHIP CL1 +/-30 330 5%
C120	2113743L41	CAP CHIP 10000 PF 10% X7R
C121	2113740F63	CAP CHIP CL1 +/-30 330 5%
C122	2113743L21	CAP CHIP 1500 PF 10% X7R
C123	2113743L09	CAP CHIP 470 PF 10% X7R
C124	2113946A01	CAP CER CHP 0.015UF 16V 10%
C125	2113743L41	CAP CHIP 10000 PF 10% X7R
C126	2113743L41	CAP CHIP 10000 PF 10% X7R
C13	2113743S01	CAP CER CHIP 1.0 UF 10% 16V
C130	2113743E20	CAP CHIP .10 UF 10%
C131	2311049A37	CAP TANT CHIP 1 20 20
C133	2113743L41	CAP CHIP 10000 PF 10% X7R
C134	2113740F63	CAP CHIP CL1 +/-30 330 5%
C135	2113740F63	CAP CHIP CL1 +/-30 330 5%
C136	2311049A37	CAP TANT CHIP 1 20 20
C137	2113742J08	CAP 33.0 PF 5%
C138	2113742J08	CAP 33.0 PF 5%
C139	2113742J04	CAP, 22PF 5% 0805 ACCU-P
C14	2113743S01	CAP CER CHIP 1.0 UF 10% 16V

Ref. Des.	Part Number	Description
C140	2113740F31	CAP CHIP REEL CL1 +/-30 15
C141	2113740F31	CAP CHIP REEL CL1 +/-30 15
C142	2113740F63	CAP CHIP CL1 +/-30 330 5%
C143	2113740F63	CAP CHIP CL1 +/-30 330 5%
C144	2113740F63	CAP CHIP CL1 +/-30 330 5%
C145	2113740F31	CAP CHIP REEL CL1 +/-30 15
C146	2113743L41	CAP CHIP 10000 PF 10% X7R
C147	2113740F47	CAP CHIP REEL CL1 +/-30 68
C148	2113740F47	CAP CHIP REEL CL1 +/-30 68
C15	2113743E20	CAP CHIP .10 UF 10%
C16	2113743N13	CAP CHIP 3.0 PF +/-25PF COG
C18	2113743S01	CAP CER CHIP 1.0 UF 10% 16V
C19	2113743L41	CAP CHIP 10000 PF 10% X7R
C2	2113743S01	CAP CER CHIP 1.0 UF 10% 16V
C20	2113743S01	CAP CER CHIP 1.0 UF 10% 16V
C201	2113743M24	CAP CHIP 100000 PF +80-20% Y5V
C202	2113743M24	CAP CHIP 100000 PF +80-20% Y5V
C203	2113743F18	CAP CHIP 2.2 UF 16V
C204	2113743M24	CAP CHIP 100000 PF +80-20% Y5V
C205	2113743M24	CAP CHIP 100000 PF +80-20% Y5V
C206	2311049A57	CAP TANT CHIP A/P 10UF 10% 16V

Ref. Des.	Part Number	Description
C207	2113743M24	CAP CHIP 100000 PF +80-20% Y5V
C208	2113743M24	CAP CHIP 100000 PF +80-20% Y5V
C209	2113743M24	CAP CHIP 100000 PF +80-20% Y5V
C21	2113743T19	CAP 10UF 16V CER 3225 X5R
C210	2113743M24	CAP CHIP 100000 PF +80-20% Y5V
C211	2113743M24	CAP CHIP 100000 PF +80-20% Y5V
C212	2113743L01	CAP CHIP 220 PF 10% X7R
C213	2113743L17	CAP CHIP 1000 PF 10% X7R
C214	2113743N50	CAP CHIP 100 PF 5% COG
C215	2113743M24	CAP CHIP 100000 PF +80-20% Y5V
C216	2113743M24	CAP CHIP 100000 PF +80-20% Y5V
C217	2113743E12	CAP CHIP .047 UF 10% X7R
C218	2113743E12	CAP CHIP .047 UF 10% X7R
C219	2109720D20	CAP CHIP LOW DIST 2000 SOV
C22	2113743T19	CAP 10UF 16V CER 3225 X5R
C220	2311049A57	CAP TANT CHIP A/P 10UF 10% 16V
C221	2113743M24	CAP CHIP 100000 PF +80-20% Y5V
C222	2113743L33	CAP CHIP 4700 PF 10% X7R
C224	2109720D14	CAP CER CHIP LOW DIST .1 UF
C225	2109720D14	CAP CER CHIP LOW DIST .1 UF
C226	2109720D14	CAP CER CHIP LOW DIST .1 UF

Ref. Des.	Part Number	Description
C227	2109720D14	CAP CER CHIP LOW DIST .1 UF
C229	2113743N50	CAP CHIP 100 PF 5% COG
C23	2113743T19	CAP 10UF 16V CER 3225 X5R
C230	2113743L05	CAP CHIP 330 PF 10% X7R
C231	2113743L41	CAP CHIP 10000 PF 10% X7R
C232	2311049A57	CAP TANT CHIP A/P 10UF 10% 16V
C233	2113743M24	CAP CHIP 100000 PF +80-20% Y5V
C234	2113743L41	CAP CHIP 10000 PF 10% X7R
C235	2113743N50	CAP CHIP 100 PF 5% COG
C237	2113743N38	CAP CHIP 33.0 PF 5% COG
C238	NOTPLACED	NOT PLACED
C24	2113743T19	CAP 10UF 16V CER 3225 X5R
C240	2109720D14	CAP CER CHIP LOW DIST .1 UF
C241	2109720D14	CAP CER CHIP LOW DIST .1 UF
C28	2113743L17	CAP CHIP 1000 PF 10% X7R
C3	2113743T19	CAP 10UF 16V CER 3225 X5R
C301	2113740F29	CAP CHIP REEL CL1 +/-30 12
C302	2113740F29	CAP CHIP REEL CL1 +/-30 12
C303	2113740F28	CAP CHIP REEL CL1 +/-30 11
C304	2113740F31	CAP CHIP REEL CL1 +/-30 15
C305	2113740F15	CAP CHIP REEL CL1 +/-30 3.3
C306	2104801Z12	CAP CER NPO 1.8PF 16V 1005 SMD

Ref. Des.	Part Number	Description
C307	2113740F03	CAP CHIP REEL CL1 +/-30 1.0
C308	2113743Q03	CAP CHIP 1.0 PF +/-1PF 20*40
C309	2113740F63	CAP CHIP CL1 +/-30 330 5%
C310	2113743L05	CAP CHIP 330 PF 10% X7R
C313	2113743E20	CAP CHIP .10 UF 10%
C314	2113743L05	CAP CHIP 330 PF 10% X7R
C315	2113743L05	CAP CHIP 330 PF 10% X7R
C316	2104801Z06	CAP CER NPO 1.0PF 16V 1005 SMD
C317	2104801Z12	CAP CER NPO 1.8PF 16V 1005 SMD
C318	2113743L05	CAP CHIP 330 PF 10% X7R
C319	2113743L05	CAP CHIP 330 PF 10% X7R
C320	2113743L05	CAP CHIP 330 PF 10% X7R
C321	2104801Z12	CAP CER NPO 1.8PF 16V 1005 SMD
C322	2113743L05	CAP CHIP 330 PF 10% X7R
C333	2113743L05	CAP CHIP 330 PF 10% X7R
C4	2113743L41	CAP CHIP 10000 PF 10% X7R
C401	2113743E20	CAP CHIP .10 UF 10%
C403	2113743N30	CAP CHIP 15.0 PF 5% COG
C405	2113743N26	CAP CHIP 10.0 PF 5% COG
C408	2113743N30	CAP CHIP 15.0 PF 5% COG
C411	2113740F67	CAP CHIP CL1 +/-30 470 5%
C412	2113740F20	CAP CHIP REEL CL1 +/-30 5.1
C416	2113743N40	CAP CHIP 39.0 PF 5% COG
C417	2113743E20	CAP CHIP .10 UF 10%
C419	2113743E20	CAP CHIP .10 UF 10%
C421	2113743N25	CAP CHIP 9.1 PF + -.5PF COG
C425	2113743E20	CAP CHIP .10 UF 10%

Ref. Des.	Part Number	Description
C429	2113743Q22	CAP CHIP 6.8 PF +/-0.25 PF 16V
C433	2113743E20	CAP CHIP .10 UF 10%
C435	2113743E20	CAP CHIP .10 UF 10%
C437	2113743N30	CAP CHIP 15.0 PF 5% COG
C439	2113743N26	CAP CHIP 10.0 PF 5% COG
C443	2113743N30	CAP CHIP 15.0 PF 5% COG
C445	2113740F67	CAP CHIP CL1 +/-30 470 5%
C446	2113740F20	CAP CHIP REEL CL1 +/-30 5.1
C449	2113743N40	CAP CHIP 39.0 PF 5% COG
C450	2113743E20	CAP CHIP .10 UF 10%
C451	2113743N35	CAP 24PF 20X40
C452	2113743N14	CAP CHIP 3.3 PF +/-25PF COG
C454	2113740F63	CAP CHIP CL1 +/-30 330 5%
C455	2113740F63	CAP CHIP CL1 +/-30 330 5%
C456	2113743E20	CAP CHIP .10 UF 10%
C457	2113743N30	CAP CHIP 15.0 PF 5% COG
C458	2113740F33	CAP CHIP REEL CL1 +/-30 18
C5	2113743T19	CAP 10UF 16V CER 3225 X5R
C501	2113740F58	CAP CHIP REEL CL1 +/-30 200
C502	2113743M24	CAP CHIP 100000 PF +80-20% Y5V
C503	2113928E01	CAP CER CHIP 1.0 UF 10 % 10V
C515	2113743L41	CAP CHIP 10000 PF 10% X7R
C516	2113743M24	CAP CHIP 100000 PF +80-20% Y5V
C517	2113743M24	CAP CHIP 100000 PF +80-20% Y5V

Ref. Des.	Part Number	Description
C518	2113743E12	CAP CHIP .047 UF 10% X7R
C519	2113743M24	CAP CHIP 100000 PF +80-20% Y5V
C520	2113743M24	CAP CHIP 100000 PF +80-20% Y5V
C521	2113743M24	CAP CHIP 100000 PF +80-20% Y5V
C522	2113743E12	CAP CHIP .047 UF 10% X7R
C523	2113743N50	CAP CHIP 100 PF 5% COG
C524	2113743N50	CAP CHIP 100 PF 5% COG
C525	2113743M24	CAP CHIP 100000 PF +80-20% Y5V
C526	2113743L25	CAP CHIP 2200 PF 10% X7R
C528	2113743M24	CAP CHIP 100000 PF +80-20% Y5V
C529	2113743M24	CAP CHIP 100000 PF +80-20% Y5V
C530	2113743E12	CAP CHIP .047 UF 10% X7R
C532	2113743M24	CAP CHIP 100000 PF +80-20% Y5V
C533	2113743N50	CAP CHIP 100 PF 5% COG
C534	2113743N50	CAP CHIP 100 PF 5% COG
C535	2113743N46	QAP CHIP 68.0 PF 5% COG
C536	2113743E10	CAP CHIP .033 UF 10% X7R
C537	2113743M24	CAP CHIP 100000 PF +80-20% Y5V
C539	2113743L41	CAP CHIP 10000 PF 10% X7R
C541	2113743M24	CAP CHIP 100000 PF +80-20% Y5V
C543	2113743M24	CAP CHIP 100000 PF +80-20% Y5V
C547	2113740F33	CAP CHIP REEL CL1 +/-30 18

Ref. Des.	Part Number	Description
C550	2311049A62	CAP TAN CHIP A/P 4.7 10 10
C552	2113743L41	CAP CHIP 10000 PF 10% X7R
C553	2311049A62	CAP TAN CHIP A/P 4.7 10 10
C554	2113743N43	CAP CHIP 51.0 PF 5% COG
C555	2113743N45	CAP CHIP 62.0 PF 5% COG
C556	2113743N46	QAP CHIP 68.0 PF 5% COG
C557	2113743N50	CAP CHIP 100 PF 5% COG
C558	2113743A24	CAP CHIP .330 UF 10% 16V
C559	2113928E01	CAP CER CHIP 1.0 UF 10 % 10V
C560	2113740F33	CAP CHIP REEL CL1 +/-30 18
C570	2113743E20	CAP CHIP .10 UF 10%
C571	2113743E20	CAP CHIP .10 UF 10%
C6	2113743S01	CAP CER CHIP 1.0 UF 10% 16V
C7	2113743L41	CAP CHIP 10000 PF 10% X7R
C701	2113740F20	CAP CHIP REEL CL1 +/-30 5.1
C703	2113740F24	CAP CHIP REEL CL1 +/-30 7.5
C704	2113740F30	CAP CHIP REEL CL1 +/-30 13
C706	2113743L41	CAP CHIP 10000 PF 10% X7R
C709	2113740F31	CAP CHIP REEL CL1 +/-30 15
C710	2113740F41	CAP CHIP REEL CL1 +/-30 39
C712	2113740F27	CAP CHIP REEL CL1 +/-30 10
C713	2113740F30	CAP CHIP REEL CL1 +/-30 13

Ref. Des.	Part Number	Description
C714	2113740F18	CAP CHIP REEL CL1 +/-30 4.3
C715	2113740F27	CAP CHIP REEL CL1 +/-30 10
C716	2113740F26	CAP CHIP REEL CL1 +/-30 9.1
C718	2113740F59	CAP CHIP REEL CL1 +/-30 220
C720	2113740F20	CAP CHIP REEL CL1 +/-30 5.1
C721	2113743E20	CAP CHIP .10 UF 10%
C723	2113740F59	CAP CHIP REEL CL1 +/-30 220
C724	2113740F63	CAP CHIP CL1 +/-30 330 5%
C729	NOTPLACED	NOT PLACED
C731	2113928E01	CAP CER CHIP 1.0 UF 10 % 10V
C8	2113743S01	CAP CER CHIP 1.0 UF 10% 16V
C9	2113743S01	CAP CER CHIP 1.0 UF 10% 16V
D1	4813833A20	DIODE SCHOTTKY 1A 40V PWRMITE
D101	4802197J83	DUAL SHOTTKY DIODE MBD330DWT1
D102	4802197J83	DUAL SHOTTKY DIODE MBD330DWT1
D103	4805129M06	DIODE MMBD7000
D2	4813833A20	DIODE SCHOTTKY 1A 40V PWRMITE
D201	4802233J09	DIODE TRIPLE SOT25-RH
D202	4802233J09	DIODE TRIPLE SOT25-RH
D3	4813833A20	DIODE SCHOTTKY 1A 40V PWRMITE
D301	4805649Q13	DIODE VCTR ISV 228
D302	4805649Q13	DIODE VCTR ISV 228
D303	4805649Q13	DIODE VCTR ISV 228

Ref. Des.	Part Number	Description
D4	4813833A20	DIODE SCHOTTKY 1A 40V PWRMITE
D407	4809877C13	DIODE VARACTOR ISV305 SMD
D413	4809877C13	DIODE VARACTOR ISV305 SMD
D441	4809877C13	DIODE VARACTOR ISV305 SMD
D447	4809877C13	DIODE VARACTOR ISV305 SMD
D501	4809877C08	DIODE VARACTOR 1SV279 SMD
D550	4805656W41	DIODE VARACTOR 40PF@1V 15PF@3V
D707	4805656W24	DIODE, PIN RF
D717	4805656W24	DIODE, PIN RF
D722	4805656W40	DIODES SCHOTTKY BARRIER
D727	NOTPLACED	NOT PLACED
E1	2405688Z01	INDUCTOR FERRITE BEAD
E101	2405688Z01	INDUCTOR FERRITE BEAD
E102	2480574F01	IND FERRITE CHIP 600 OHM 0603
E105	2480574F01	IND FERRITE CHIP 600 OHM 0603
E4	2405688Z01	INDUCTOR FERRITE BEAD
E5	2480640Z01	SURFACE MOUNT FERRITE BEAD
E502	2480640Z01	SURFACE MOUNT FERRITE BEAD
E504	2480640Z01	SURFACE MOUNT FERRITE BEAD
E507	2462587N76	CHIP IND 4700 NH 5%
E6	2480640Z01	SURFACE MOUNT FERRITE BEAD
E7	2480640Z01	SURFACE MOUNT FERRITE BEAD

Ref. Des.	Part Number	Description
E8	2480640Z01	SURFACE MOUNT FERRITE BEAD
F901	6505757V02	FUSE SURFACE MT 2AMP
FL200	9185130D01	FLTR SW CAP 3 POLE BUTTERW
FL451	9185875D01	CRYSTAL FILTER 44.85 MHZ
G1	3905643V01	CONTACT ANT GRD
G10	3905643V01	CONTACT ANT GRD
G12	3905643V01	CONTACT ANT GRD
G2	3905643V01	CONTACT ANT GRD
G5	3905643V01	CONTACT ANT GRD
G6	3905643V01	CONTACT ANT GRD
G7	3905643V01	CONTACT ANT GRD
G9	3905643V01	CONTACT ANT GRD
J1	NOTPLACED	NOT PLACED
J2	0905304Z01	CONN COAXIAL SMT
L1	2486085A06	COIL 47UH SMT POWER INDUCTOR
L101	2460591E24	COIL AIR WOUND INDUC 23.75
L103	2462587N56	CHIP IND 180 NH 5%
L106	2485930A13	IND 33.0NH 5%
L107	2413926G11	IND 22.0 NH 5%
L108	2462587N68	CHIP IND 1000 NH 5%
L109	2485930A05	IND 6.8 NH 5%
L112	2479990B01	AIR WND COIL/GREEN COLOR 11.03
L113	2409348J01	IND AIR CORE 1.65NH 10% 2214
L114	2460591M62	COIL AIR WOUND INDUC 25.22
L120	2485930A10	IND 18.0NH 5%
L121	2485930A10	IND 18.0NH 5%
L2	2462587L50	FERRITE INDUCTOR 100UH

Ref. Des.	Part Number	Description
L201	2462587Q20	IND CHIP 2,200 NH 20%
L202	2462587Q20	IND CHIP 2,200 NH 20%
L203	2462587Q20	IND CHIP 2,200 NH 20%
L204	2462587Q20	IND CHIP 2,200 NH 20%
L205	2462587Q47	IND CHIP 1,000 NH 10%
L207	2462587Q47	IND CHIP 1,000 NH 10%
L208	2462587Q20	IND CHIP 2,200 NH 20%
L301	2462587T30	IND CHIP 1000NH 5% LOW PRO
L302	2462587T30	IND CHIP 1000NH 5% LOW PRO
L303	2462587T30	IND CHIP 1000NH 5% LOW PRO
L304	2462587T30	IND CHIP 1000NH 5% LOW PRO
L305	2460591C35	COIL AIR WOUND INDUC 18.08
L306	2460591C03	COIL AIR WOUND INDUC 11.87
L307	2462587N48	CHIP IND 39 NH 5%
L308	2462587N46	COIL INDUCTOR
L309	2462587T37	IND CHIP 18NH 5% LOW PRO
L310	2462587T17	IND CHIP 150NH 5% LOW PRO
L311	2462587T18	IND CHIP 180NH 5% LOW PRO
L312	2462587T30	IND CHIP 1000NH 5% LOW PRO
L402	2462587V33	CHIP IND 82 NH 5% 0805
L404	2462587V34	CHIP IND 100 NH 5% 0805
L410	2462587V27	CHIP IND 27 NH 5% 0805
L414	2462587V26	CHIP IND 22 NH 5% 0805
L418	2462587V38	CHIP IND 220 NH 5% 0805
L420	2462587V31	CHIP IND 56 NH 5% 0805
L427	2462587V26	CHIP IND 22 NH 5% 0805
L431	2462587V34	CHIP IND 100 NH 5% 0805

Ref. Des.	Part Number	Description
L434	2462587V35	CHIP IND 120 NH 5% 0805
L436	2462587V33	CHIP IND 82 NH 5% 0805
L438	2462587V34	CHIP IND 100 NH 5% 0805
L444	2462587V27	CHIP IND 27 NH 5% 0805
L448	2462587V26	CHIP IND 22 NH 5% 0805
L451	2462587V23	CHIP IND 12 NH 5% 0805
L452	2462587V29	CHIP IND 39 NH 5% 0805
L453	2462587Q40	IND CHIP 270 NH 10%
L454	2462587V73	IND CHIP 820.0 NH 5%
L455	2462587V74	INDUCTOR
L501	2405769X05	COIL INDUCTOR
L502	2405769X05	COIL INDUCTOR
L503	2462587Q54	IND CHIP 3,900 NH 10%
L504	2462587N76	CHIP IND 4700 NH 5%
L508	2462587Q51	IND CHIP 2,200 NH 10%
L542	2462587V74	INDUCTOR
L550	2462587N59	CHIP IND 330NH 5%
L702	2460591G24	COIL AIR WOUND INDUC 33.47
L705	2462587T30	IND CHIP 1000NH 5% LOW PRO
L708	2460591E81	COIL AIR WOUND INDUC 52.29
L711	2460591G24	COIL AIR WOUND INDUC 33.47
L715	2460591D81	COIL AIR WOUND INDUC 43.41
L719	2462587T19	IND CHIP 220NH 5% LOW PRO
P1	NOTPLACED	NOT PLACED
PCB	8485369D01	PCB RF VHF
Q1	4813821A47	TSTR P-CH HDTMOS 20V
Q101	4813824A42	TSTR PNP 50V BIAS RES 10K 10K
Q102	4813821A47	TSTR P-CH HDTMOS 20V

Ref. Des.	Part Number	Description
Q103	4813824A42	TSTR PNP 50V BIAS RES 10K 10K
Q104	4813821A47	TSTR P-CH HDTMOS 20V
Q105	4805128M12	TSTR SOT BCW 60B (RH)
Q106	4880048M01	TSTR NPN DIG 47K/47K
Q107	5185633C28	MODULE 24 CELL PWR AMPLIFIER
Q108	4805128M12	TSTR SOT BCW 60B (RH)
Q2	4880048M01	TSTR NPN DIG 47K/47K
Q201	4880048M01	TSTR NPN DIG 47K/47K
Q301	4805921T11	XSTR DUAL PNP
Q428	4805218N63	RF TRANS SOT 323 Bfq67w
Q501	4805128M19	TSTR SOT23 MMBTA13 RH
Q502	4805218N63	RF TRANS SOT 323 Bfq67w
Q503	4813821A47	TSTR P-CH HDTMOS 20V
R1	0662057N23	RES. CHIP 100K 5% 20X40
R101	0662057N23	RES. CHIP 100K 5% 20X40
R102	0662057M01	RES. CHIP 0 5% 20X40
R105	0662057M98	RES. CHIP 10K 5% 20X40
R106	0662057N13	RES. CHIP 39K 5% 20X40
R107	0662057M90	RES. CHIP 4700 5% 20X40
R108	0662057M90	RES. CHIP 4700 5% 20X40
R109	0662057T68	RES CHIP1.0K 1% 30X60
R110	0662057T68	RES CHIP1.0K 1% 30X60
R111	0662057N23	RES. CHIP 100K 5% 20X40
R112	0662057N23	RES. CHIP 100K 5% 20X40
R113	0662057N23	RES. CHIP 100K 5% 20X40
R114	0662057N23	RES. CHIP 100K 5% 20X40
R115	0662057M74	RES. CHIP 1000 5% 20X40
R118	0662057M50	RES. CHIP 100 5% 20X40
R119	0662057M50	RES. CHIP 100 5% 20X40
R120	0662057M50	RES. CHIP 100 5% 20X40

Ref. Des.	Part Number	Description
R121	0662057M50	RES. CHIP 100 5% 20X40
R122	0662057M74	RES. CHIP 1000 5% 20X40
R124	0662057N23	RES. CHIP 100K 5% 20X40
R126	0662057M98	RES. CHIP 10K 5% 20X40
R127	0662057M98	RES. CHIP 10K 5% 20X40
R128	0662057M98	RES. CHIP 10K 5% 20X40
R129	0662057M98	RES. CHIP 10K 5% 20X40
R130	0662057A37	CHIP RES 330 OHMS 5%
R201	0662057N17	RES. CHIP 56K 5% 20X40
R202	0662057M81	RES. CHIP 2000 5% 20X40
R204	0662057N17	RES. CHIP 56K 5% 20X40
R205	0662057N13	RES. CHIP 39K 5% 20X40
R207	NOTPLACED	NOT PLACED
R208	0662057N17	RES. CHIP 56K 5% 20X40
R209	0662057N23	RES. CHIP 100K 5% 20X40
R210	0662057M58	RES. CHIP 220 5% 20X40
R211	0662057M74	RES. CHIP 1000 5% 20X40
R212	0662057M48	RES. CHIP 82 5% 20X40
R213	0662057M98	RES. CHIP 10K 5% 20X40
R214	0662057M74	RES. CHIP 1000 5% 20X40
R215	0662057M98	RES. CHIP 10K 5% 20X40
R217	0662057M70	DES. CHIP 680 5% 20X40
R218	0662057M96	RES. CHIP 8200 5% 20X40
R301	0662057M37	20X40 30 OMH 5% CHIP RESISTOR
R302	0662057M38	RES. CHIP 33 5% 20X40
R303	0662057M38	RES. CHIP 33 5% 20X40
R304	0662057M98	RES. CHIP 10K 5% 20X40
R305	0662057M98	RES. CHIP 10K 5% 20X40
R306	0662057M62	RES. CHIP 330 5% 20X40
R307	0662057M60	RES. CHIP 270 5% 20X40
R308	0662057M74	RES. CHIP 1000 5% 20X40
R309	0662057N33	RES CHIP 270K 5% 20X40

Ref. Des.	Part Number	Description
R310	0662057M98	RES. CHIP 10K 5% 20X40
R313	0662057M58	RES. CHIP 220 5% 20X40
R314	0662057M66	RES. CHIP 470 5% 20X40
R315	0662057M30	RES. CHIP 15 5% 20X40
R316	0662057M66	RES. CHIP 470 5% 20X40
R317	0662057M38	RES. CHIP 33 5% 20X40
R318	0662057M43	RES. CHIP 51 5% 20X40
R319	0662057M62	RES. CHIP 330 5% 20X40
R409	0662057N29	RES CHIP 180K 5% 20X40
R415	0662057N29	RES CHIP 180K 5% 20X40
R422	0662057M26	RES. CHIP 10 5% 20X40
R423	0662057N29	RES CHIP 180K 5% 20X40
R424	0662057N29	RES CHIP 180K 5% 20X40
R426	0662057M84	RES. CHIP 2700 5% 20X40
R430	0662057M26	RES. CHIP 10 5% 20X40
R432	0662057A09	CHIP RES 22 OHMS 5%
R442	0662057N29	RES CHIP 180K 5% 20X40
R449	0662057N29	RES CHIP 180K 5% 20X40
R451	0662057M37	20X40 30 OMH 5% CHIP RESISTOR
R452	0662057M36	RES. CHIP 27 5% 20X40
R453	0662057M36	RES. CHIP 27 5% 20X40
R454	0662057M92	RES. CHIP 5600 5% 20X40
R455	0662057M92	RES. CHIP 5600 5% 20X40
R456	0662057M54	RES. CHIP 150 5% 20X40
R501	0662057N17	RES. CHIP 56K 5% 20X40
R502	0662057M63	RES CHIP 360 5% 20X40
R503	0662057N05	RES. CHIP 18K 5% 20X40
R506	0662057N01	RES CHIP 12K 5% 20X40
R507	0662057M75	RESISTOR
R508	0662057M69	RES. CHIP 620 5% 20X40
R510	0662057M98	RES. CHIP 10K 5% 20X40
R511	0662057N23	RES. CHIP 100K 5% 20X40

Ref. Des.	Part Number	Description
R512	0662057M98	RES. CHIP 10K 5% 20X40
R513	0662057M98	RES. CHIP 10K 5% 20X40
R514	0662057M80	RES. CHIP 1800 5% 20X40
R6	0662057M98	RES. CHIP 10K 5% 20X40
R7	0662057M98	RES. CHIP 10K 5% 20X40
R701	0662057A23	CHIP RES 82 OHMS 5%
R702	0662057A23	CHIP RES 82 OHMS 5%
R721	NOTPLACED	NOT PLACED
R723	0662057M50	RES. CHIP 100 5% 20X40
R724	0662057M50	RES. CHIP 100 5% 20X40
R725	0662057M81	RES. CHIP 2000 5% 20X40
R726	0662057M81	RES. CHIP 2000 5% 20X40
R727	NOTPLACED	NOT PLACED
R8	0662057M50	RES. CHIP 100 5% 20X40
SH101	2685074D01	SHIELD PA
SH201	2685787B01	SHLD FRAC-N
SH202	2685787B01	SHLD FRAC-N
SH301	2685297D01	SHLD VCO
SH302	2685310E01	SHIELD VCO BUFFER
SH401	2685071D01	SHIELD 16.8 REF
SH402	2685153E01	SHIELD LNA
SH450	2685965D01	SHIELD MIXER
SH451	2685070D01	SHIELD CRYSTAL FILTER
SH501	2685787B01	SHLD FRAC-N
SH502	2685786D01	SHIELD ABACUS 2ND LO
SH701	2685784D01	SHIELD HARMONIC FILTER
T451	2580541Z02	BALUN TRANSFORMER (NEW)
T452	2585918C02	XFRMR SMALL SIGNAL SURFACE MOUNT
T453	2585918C01	XFMR SMALL SIGNAL SURFACE MT
U1	5185353D13	IC MINI SO-8 HI PRECISION REG 5V

Ref. Des.	Part Number	Description
U102	5185130C65	IC VHF/UHF/800 MHZ LD MOS DRIVER
U103	5185963A15	IC TEMPERATURE SENSOR 1M50C
U104	5185765B26	IC PWR CTRL IN MOS20
U105	5185368C19	IC QUAD 10 BIT A/D CONV
U106	5185963A60	OP AMP IC
U2	5185353D14	IC SOT23-5 HI PRECISION REG 3V
U201	5186358E01	IC ANALOG OP-AMP CLC450
U202	5185963A27	IC TESTED AT25016 48 PIN GFP
U203	5185368C83	IC 12 BIT DAC
U3	5185353D14	IC SOT23-5 HI PRECISION REG 3V
U302	5105750U54	IC PKG DIE VCO BUFFER
U4	5105462G78	IC EEPROM 16K SPEI CMOS
U451	5185130C91	IC MIXER RF SOIC 10
U5	5185353D14	IC SOT23-5 HI PRECISION REG 3V
U500	5185963A85	IC-ABACUS III-LP
U725	5185130C83	IC 15DB DIGITAL ATTENUATOR SOT25 PKG
U726	5185143E12	IC INVERTER DUAL SC70
VR1	4813830A33	DIODE 20V 5% 225MW MMBZ5250B_
VR2	4813830A33	DIODE 20V 5% 225MW MMBZ5250B_
Y200	4802245J68	OSC REF 16.8 MHZ 1.5 PPM

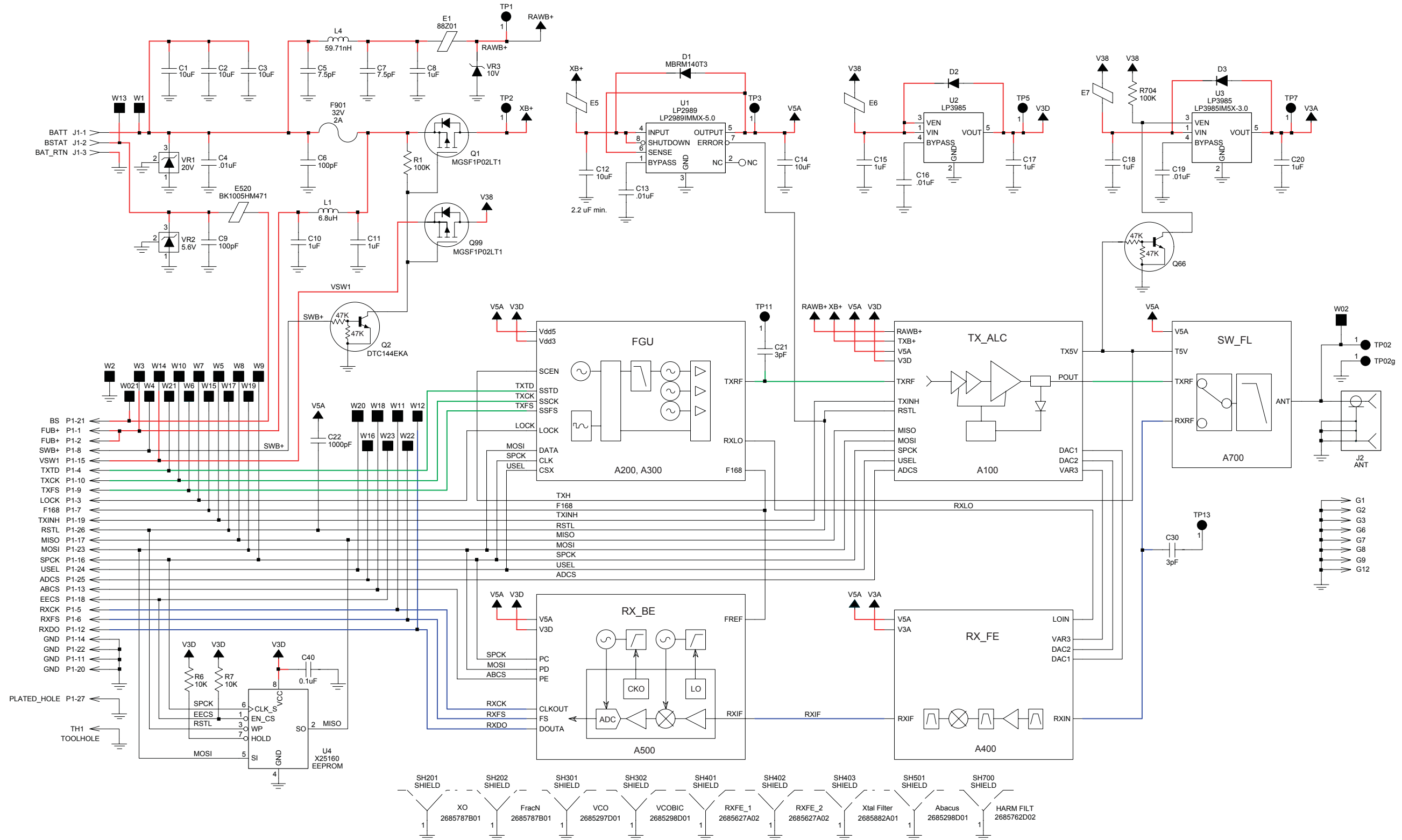

63B81096C96-O

Figure 8-31. NLE4272A UHF Range 1 Transceiver (RF) Board Overall Circuit Schematic

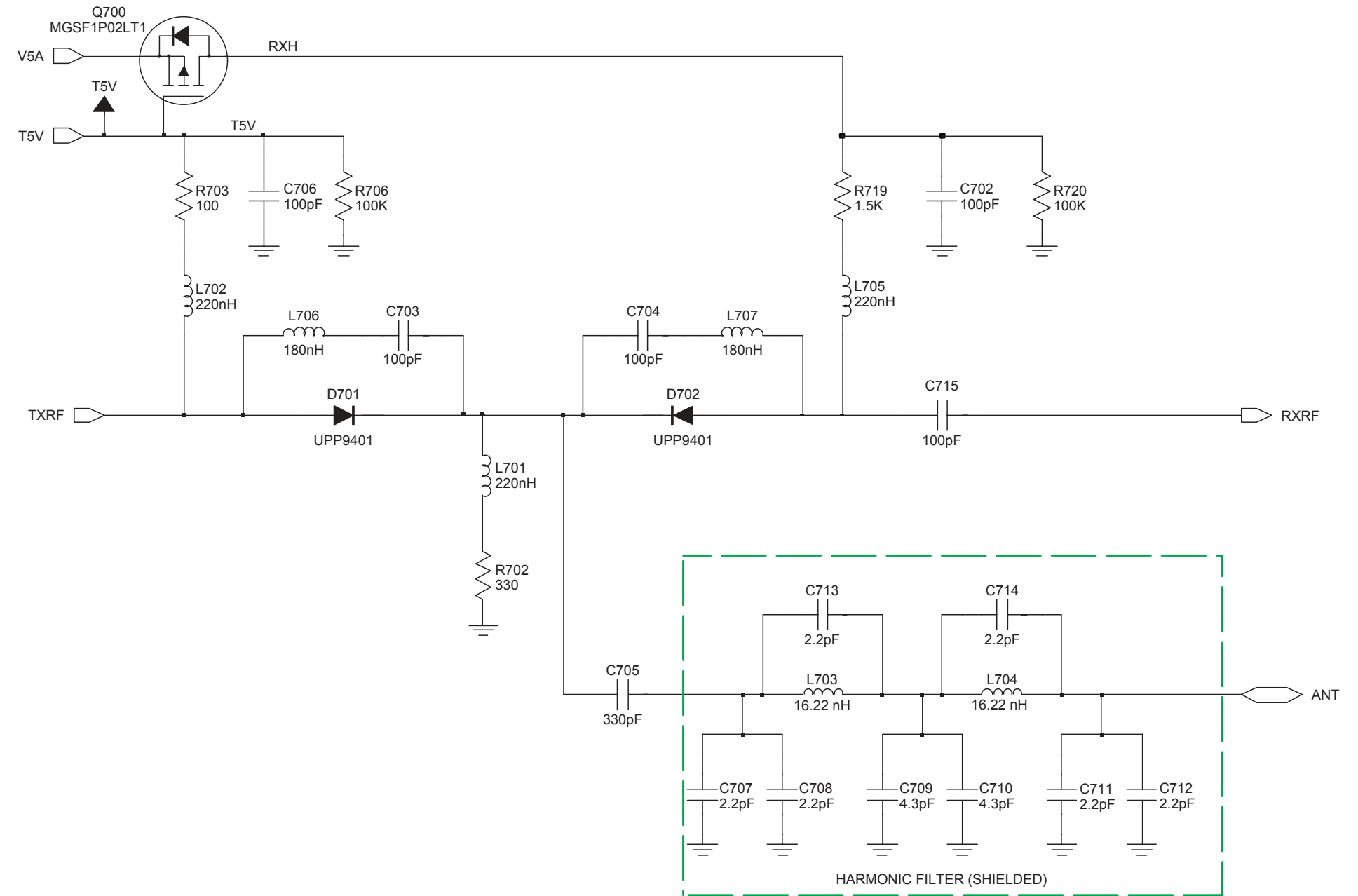

63B81096C97-O

Figure 8-32. NLE4272A UHF Range 1 Antenna Switch and Harmonic Filter Circuits

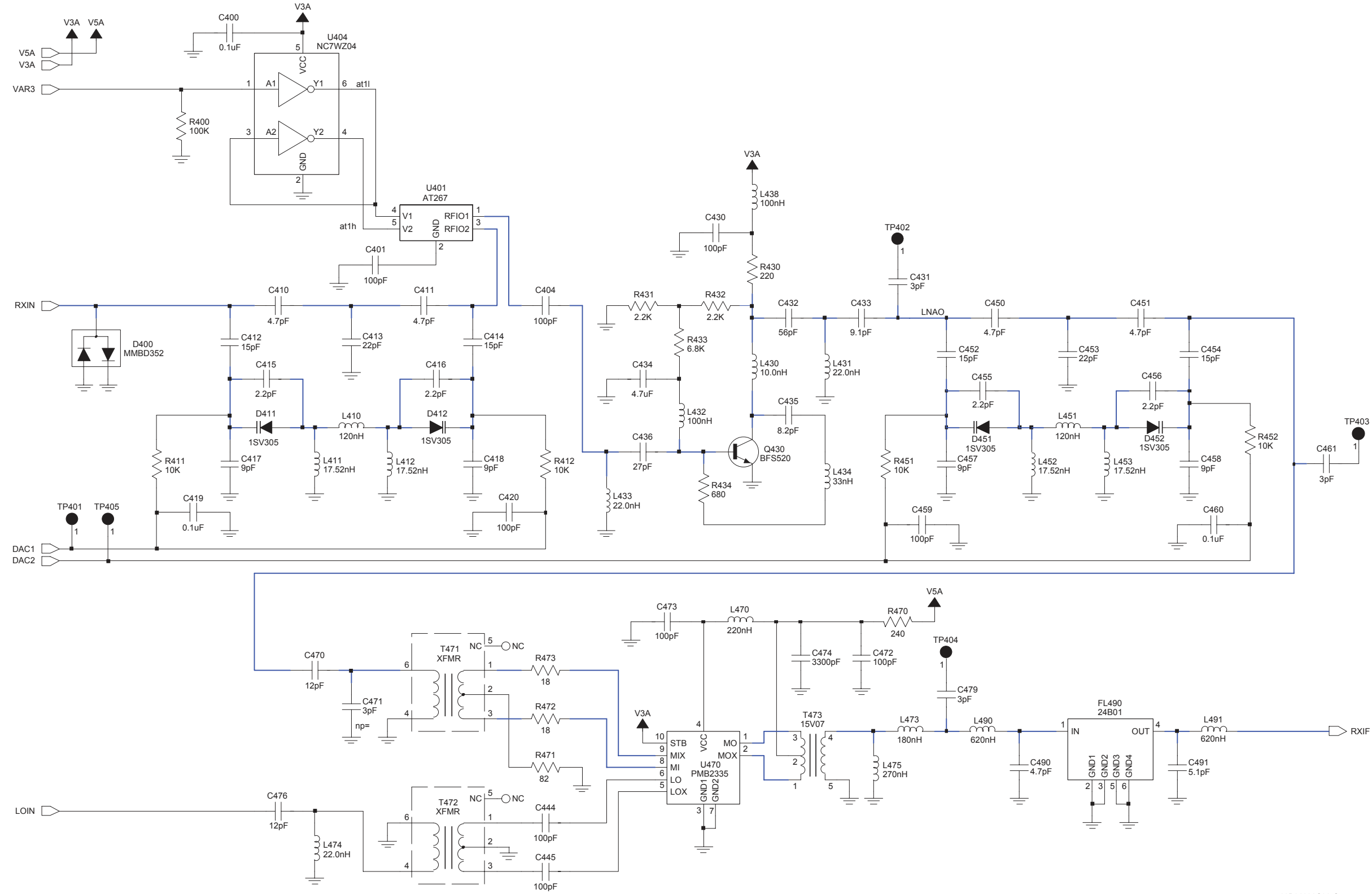

63B81096C98-O

Figure 8-33. NLE4272A UHF Range 1 Receiver Front End (RX\_FE) Circuit



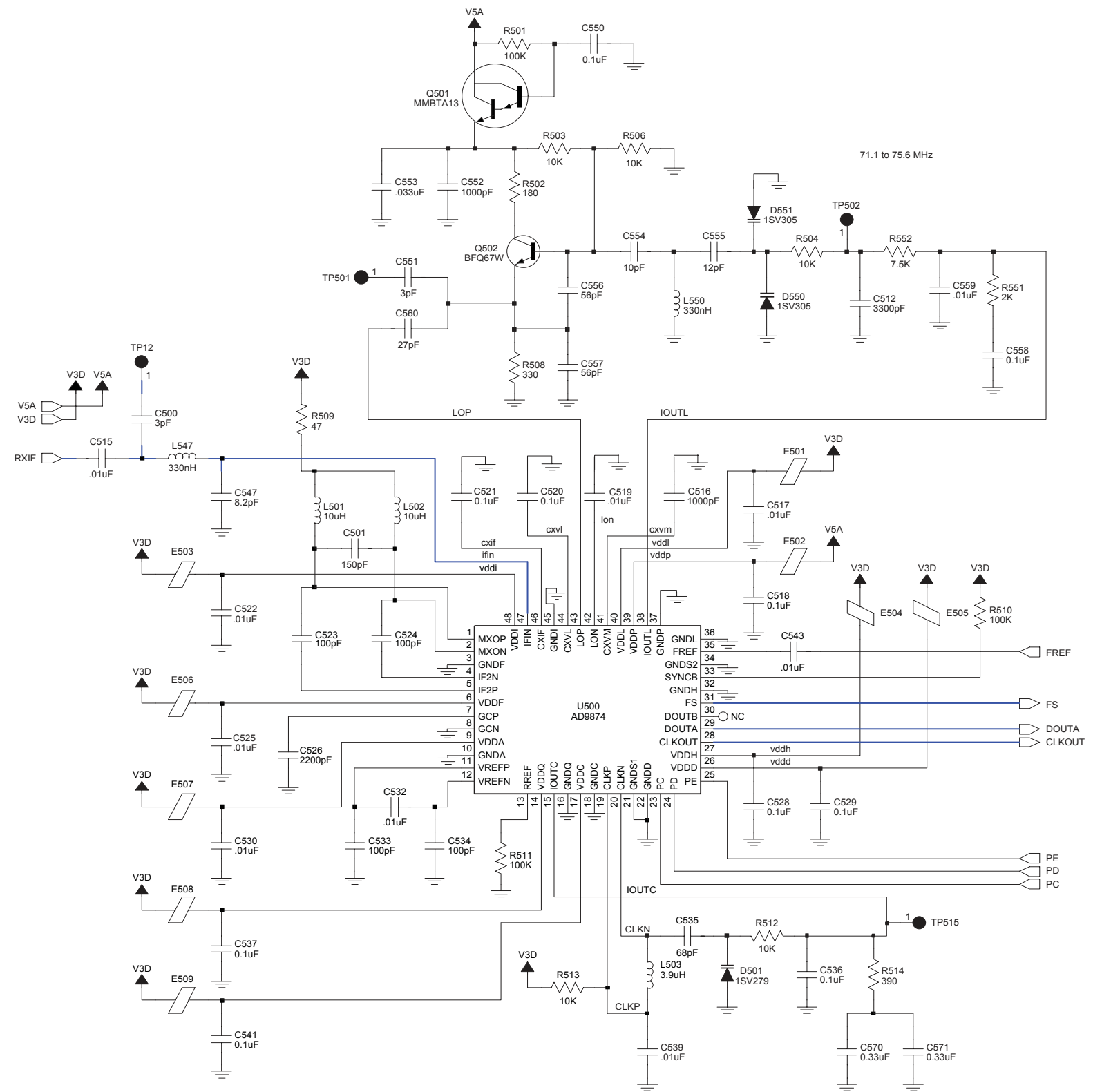

63B81096C99-0

Figure 8-34. NLE4272A UHF Range 1 Receiver Back End (RX\_BE) Circuit

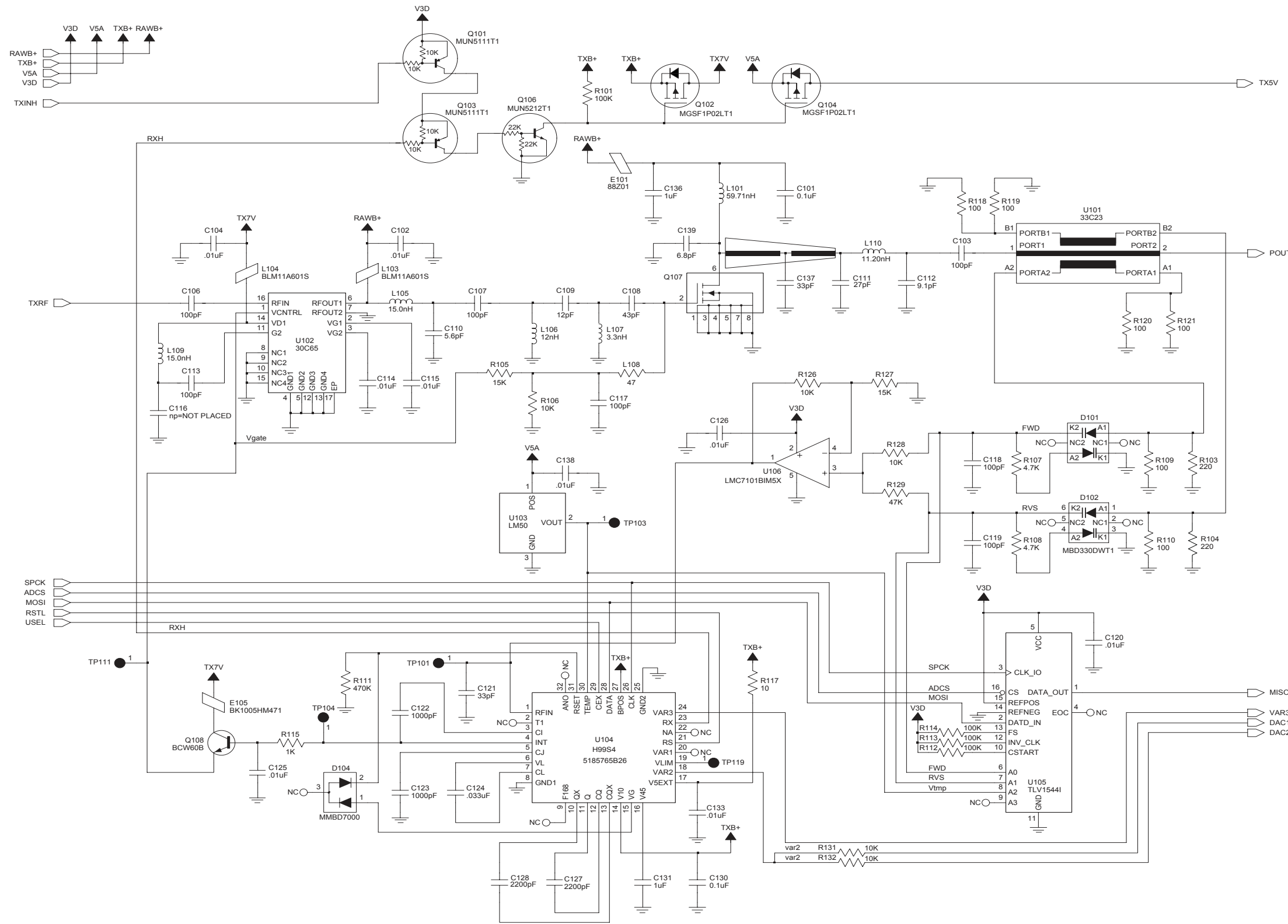

63B81097C00-O

Figure 8-35. NLE4272A UHF Range 1 Transmitter Power Amplifier and Automatic Level Control (TX\_ALC) Circuit

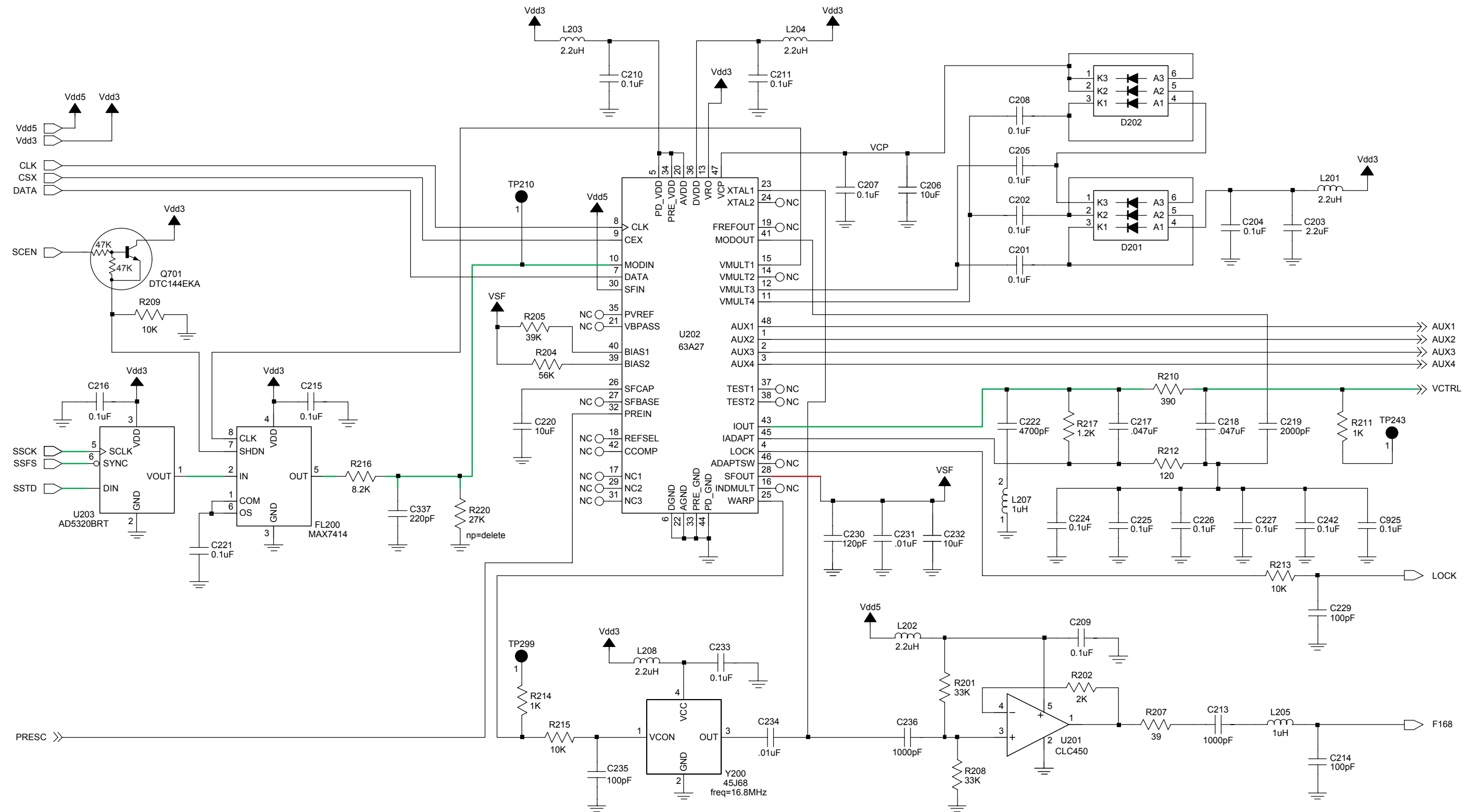

63B81097C01-O

Figure 8-36. NLE4272A UHF Range 1 Frequency Generation Unit (Synthesizer) Circuit

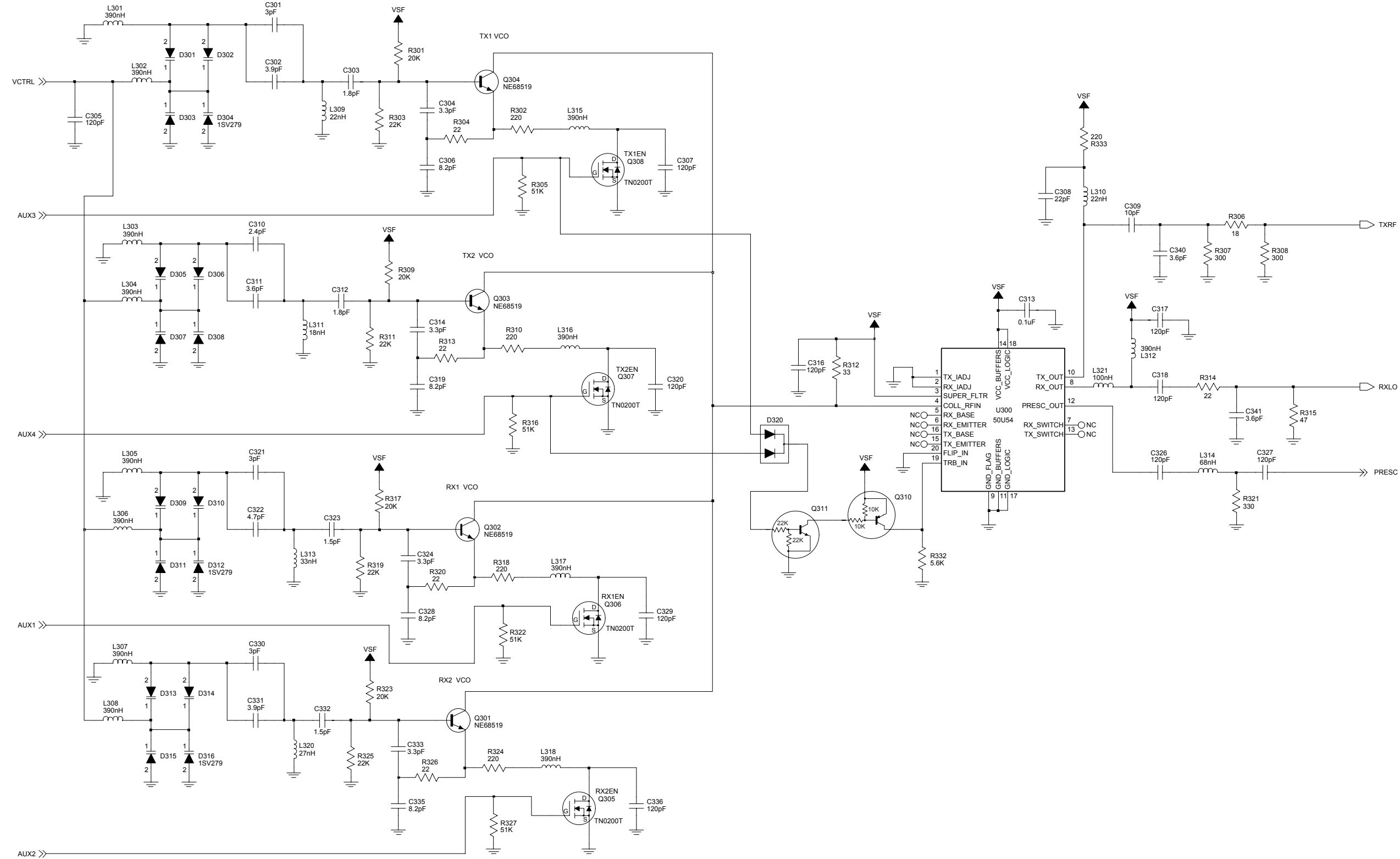

63B81097C29-O

Figure 8-37. NLE4272A UHF Range 1 Frequency Generation Unit (VCO) Circuit

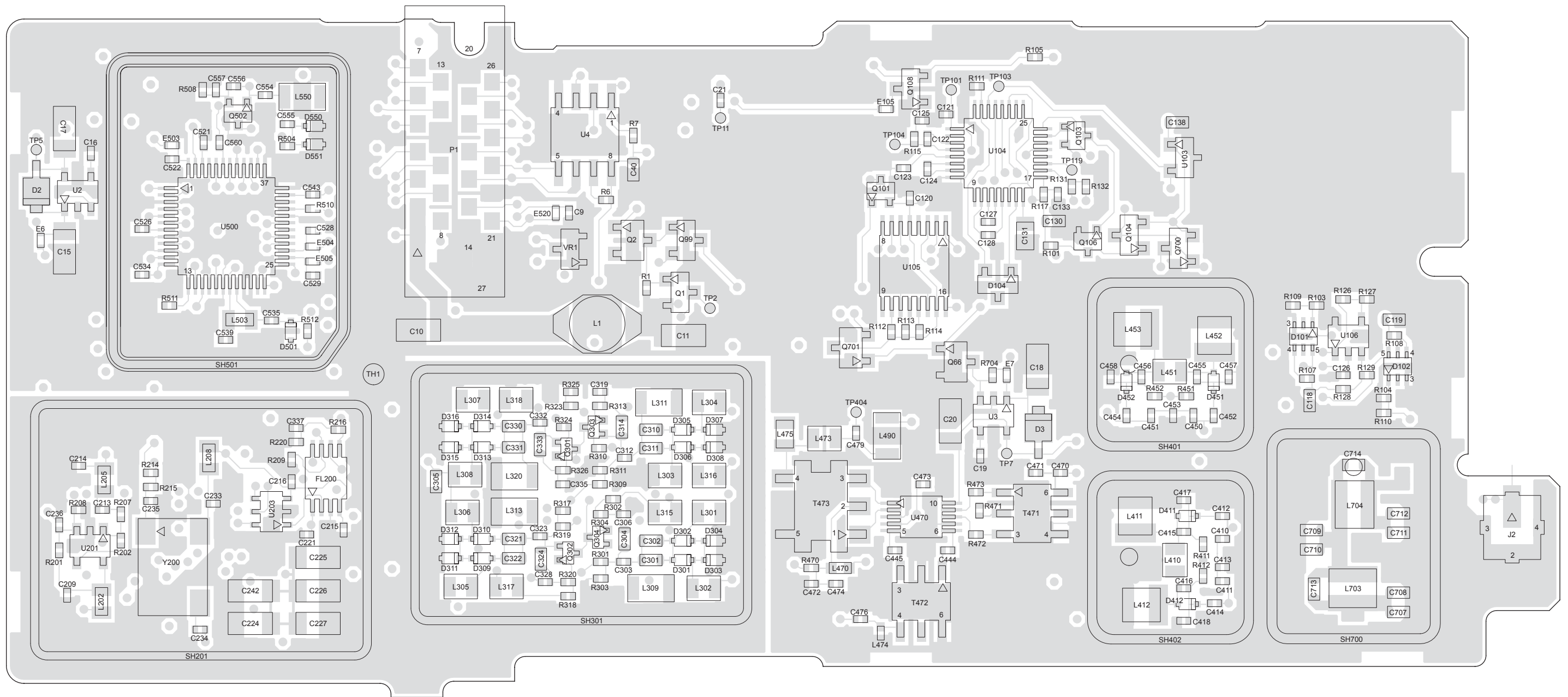

MAEPF-27597-O

Figure 8-38. NLE4272A UHF Range 1 Transceiver (RF) Board Layout—Side 1



NLE4272A UHF Range 1 Transceiver (RF)  
Board Parts List

Ref. Des.	Part Number	Description
C1	2113743T19	CAP 10UF 16V CER 3225 X5R
C10	2113743S01	CAP CER CHIP 1.0 UF 10% 16V
C101	2113743E20	CAP CHIP .10 UF 10%
C102	2113741F49	CAP CHIP CL2 X7R REEL 10000
C103	2113740F51	CAP CHIP REEL CL1 +/-30 100
C104	2113741F49	CAP CHIP CL2 X7R REEL 10000
C106	2113740F51	CAP CHIP REEL CL1 +/-30 100
C107	2113740F51	CAP CHIP REEL CL1 +/-30 100
C108	2113740F42	CAP CHIP REEL CL1 +/-30 43
C109	2113740F29	CAP CHIP REEL CL1 +/-30 12
C11	2113743S01	CAP CER CHIP 1.0 UF 10% 16V
C110	2113740F21	CAP CHIP REEL CL1 +/-30 5.6
C111	2113740F37	CAP CHIP REEL CL1 +/-30 27
C112	2113740F26	CAP CHIP REEL CL1 +/-30 9.1
C113	2113740F51	CAP CHIP REEL CL1 +/-30 100
C114	2113741F49	CAP CHIP CL2 X7R REEL 10000
C115	2113741F49	CAP CHIP CL2 X7R REEL 10000
C116	2113740F27	CAP CHIP REEL CL1 +/-30 10
C117	2113740F51	CAP CHIP REEL CL1 +/-30 100
C118	2113740F51	CAP CHIP REEL CL1 +/-30 100

Ref. Des.	Part Number	Description
C119	2113740F51	CAP CHIP REEL CL1 +/-30 100
C12	2113743T19	CAP 10UF 16V CER 3225 X5R
C120	2113743L41	CAP CHIP 10000 PF 10% X7R
C121	2113743N38	CAP CHIP 33.0 PF 5% COG
C122	2113743L17	CAP CHIP 1000 PF 10% X7R
C123	2113743L17	CAP CHIP 1000 PF 10% X7R
C124	2113743L41	CAP CHIP 10000 PF 10% X7R
C125	2113743L41	CAP CHIP 10000 PF 10% X7R
C126	2113743L41	CAP CHIP 10000 PF 10% X7R
C127	2113743L25	CAP CHIP 2200 PF 10% X7R
C128	2113743L25	CAP CHIP 2200 PF 10% X7R
C13	2113743L41	CAP CHIP 10000 PF 10% X7R
C130	2113743E20	CAP CHIP .10 UF 10%
C131	2113743A31	CAP CHIP 1.0UF 10% X7R
C133	2113743L41	CAP CHIP 10000 PF 10% X7R
C136	2113743A31	CAP CHIP 1.0UF 10% X7R
C137	2113742J08	CAP 33.0 PF 5%
C138	2113741F49	CAP CHIP CL2 X7R REEL 10000
C139	2113740F23	CAP CHIP REEL CL1 +/-30 6.8
C14	2113743T19	CAP 10UF 16V CER 3225 X5R
C15	2113743S01	CAP CER CHIP 1.0 UF 10% 16V
C16	2113743L41	CAP CHIP 10000 PF 10% X7R

Ref. Des.	Part Number	Description
C17	2113743S01	CAP CER CHIP 1.0 UF 10% 16V
C18	2113743S01	CAP CER CHIP 1.0 UF 10% 16V
C19	2113743L41	CAP CHIP 10000 PF 10% X7R
C2	2113743T19	CAP 10UF 16V CER 3225 X5R
C20	2113743S01	CAP CER CHIP 1.0 UF 10% 16V
C201	2113743M24	CAP CHIP 100000 PF +80-20% Y
C202	2113743M24	CAP CHIP 100000 PF +80-20% Y
C203	2113743F18	CAP CHIP 2.2 UF 16V
C204	2113743M24	CAP CHIP 100000 PF +80-20% Y
C205	2113743M24	CAP CHIP 100000 PF +80-20% Y
C206	2113743T19	CAP 10UF 16V CER 3225 X5R
C207	2113743M24	CAP CHIP 100000 PF +80-20% Y
C208	2113743M24	CAP CHIP 100000 PF +80-20% Y
C209	2113743M24	CAP CHIP 100000 PF +80-20% Y
C21	2113743N13	CAP CHIP 3.0 PF +/-25PF COG
C210	2113743M24	CAP CHIP 100000 PF +80-20% Y
C211	2113743M24	CAP CHIP 100000 PF +80-20% Y
C213	2113743L17	CAP CHIP 1000 PF 10% X7R
C214	2113743N50	CAP CHIP 100 PF 5% COG
C215	2113743M24	CAP CHIP 100000 PF +80-20% Y
C216	2113743M24	CAP CHIP 100000 PF +80-20% Y

Ref. Des.	Part Number	Description
C217	2113743E12	CAP CHIP .047 UF 10% X7R
C218	2113743E12	CAP CHIP .047 UF 10% X7R
C219	2109720D20	CAP CHIP LOW DIST 2000 SOV
C22	2113743L17	CAP CHIP 1000 PF 10% X7R
C220	2113743T19	CAP 10UF 16V CER 3225 X5R
C221	2113743M24	CAP CHIP 100000 PF +80-20% Y
C222	2113741F41	CAP CHIP CL2 X7R REEL 4700
C224	2109720D14	CAP CER CHIP LOW DIST .1 UF
C225	2109720D14	CAP CER CHIP LOW DIST .1 UF
C226	2109720D14	CAP CER CHIP LOW DIST .1 UF
C227	2109720D14	CAP CER CHIP LOW DIST .1 UF
C229	2113743N50	CAP CHIP 100 PF 5% COG
C230	2113743N52	CAP CHIP 120 PF 5% COG
C231	2113743L41	CAP CHIP 10000 PF 10% X7R
C232	2113743T19	CAP 10UF 16V CER 3225 X5R
C233	2113743M24	CAP CHIP 100000 PF +80-20% Y
C234	2113743L41	CAP CHIP 10000 PF 10% X7R
C235	2113743N50	CAP CHIP 100 PF 5% COG
C236	2113743L17	CAP CHIP 1000 PF 10% X7R
C242	2109720D14	CAP CER CHIP LOW DIST .1 UF
C3	2113743T19	CAP 10UF 16V CER 3225 X5R
C30	2113743N13	CAP CHIP 3.0 PF +/-25PF COG

Ref. Des.	Part Number	Description
C301	2113740L05	CAP CER CHIP 3.0 PF +- 0.1PF
C302	2113740L08	CAP CER CHIP 3.9 PF +- 0.1PF
C303	2104801Z12	CAP CER NPO 1.8PF 16V 1005 S
C304	2113740L06	CAP CER CHIP 3.3 PF +- 0.1PF
C305	2113740F53	CAP CHIP REEL CL1 +/-30 120
C306	2113743N24	CAP CHIP 8.2 PF + -.5PF COG
C307	2113743N52	CAP CHIP 120 PF 5% COG
C308	2113743N34	CAP CHIP 22.0 PF 5% COG
C309	2113743N26	CAP CHIP 10.0 PF 5% COG
C310	2113740L03	CAP CER CHIP 2.4 PF +- 0.1PF
C311	2113740L07	CAP CER CHIP 3.6 PF +- 0.1PF
C312	2104801Z12	CAP CER NPO 1.8PF 16V 1005 S
C313	2113743E20	CAP CHIP .10 UF 10%
C314	2113740L06	CAP CER CHIP 3.3 PF +- 0.1PF
C316	2113743N52	CAP CHIP 120 PF 5% COG
C317	2113743N52	CAP CHIP 120 PF 5% COG
C318	2113743N52	CAP CHIP 120 PF 5% COG
C319	2113743N24	CAP CHIP 8.2 PF + -.5PF COG
C320	2113743N52	CAP CHIP 120 PF 5% COG
C321	2113740L05	CAP CER CHIP 3.0 PF +- 0.1PF
C322	2113740L10	CAP CER CHIP 4.7 PF +- 0.1PF
C323	2104801Z10	CAP CER NPO 1.5PF 16V 1005 S
C324	2113740L06	CAP CER CHIP 3.3 PF +- 0.1PF
C326	2113743N52	CAP CHIP 120 PF 5% COG

Ref. Des.	Part Number	Description
C327	2113743N52	CAP CHIP 120 PF 5% COG
C328	2113743N24	CAP CHIP 8.2 PF + -.5PF COG
C329	2113743N52	CAP CHIP 120 PF 5% COG
C330	2113740L05	CAP CER CHIP 3.0 PF +- 0.1PF
C331	2113740L08	CAP CER CHIP 3.9 PF +- 0.1PF
C332	2104801Z10	CAP CER NPO 1.5PF 16V 1005 S
C333	2113740L06	CAP CER CHIP 3.3 PF +- 0.1PF
C335	2113743N24	CAP CHIP 8.2 PF + -.5PF COG
C336	2113743N52	CAP CHIP 120 PF 5% COG
C337	2113743L01	CAP CHIP 220 PF 10% X7R
C340	2113743N15	CAP CHIP 3.6PF +/- .25PF COG
C341	2113743N15	CAP CHIP 3.6PF +/- .25PF COG
C4	2113741F49	CAP CHIP CL2 X7R REEL 10000
C40	2113743E20	CAP CHIP .10 UF 10%
C400	2113928N01	CAP CER CHIP 0.1UF 10% 6.3
C401	2113743N50	CAP CHIP 100 PF 5% COG
C404	2113743N50	CAP CHIP 100 PF 5% COG
C410	2113743N18	CAP CHIP 4.7 PF +/- .25PF COG
C411	2113743N18	CAP CHIP 4.7 PF +/- .25PF COG
C412	2113743N30	CAP CHIP 15.0 PF 5% COG
C413	2113743N34	CAP CHIP 22.0 PF 5% COG
C414	2113743N30	CAP CHIP 15.0 PF 5% COG
C415	2113743N10	CAP CHIP 2.2 PF +/- .25PF COG
C416	2113743N10	CAP CHIP 2.2 PF +/- .25PF COG

Ref. Des.	Part Number	Description
C417	2113743N67	CAP CHIP 9.0PF 16V .5PF COG
C418	2113743N67	CAP CHIP 9.0PF 16V .5PF COG
C419	2113743E20	CAP CHIP .10 UF 10%
C420	2113743N50	CAP CHIP 100 PF 5% COG
C430	2113743N50	CAP CHIP 100 PF 5% COG
C431	2113743N13	CAP CHIP 3.0 PF +/- .25PF COG
C432	2113743N44	CAP CHIP 56.0 PF 5% COG
C433	2113743N25	CAP CHIP 9.1 PF + -.5PF COG
C434	2113928C04	CAP CER CHIP 4.7UF 6.3V10%08
C435	2113743N24	CAP CHIP 8.2 PF + -.5PF COG
C436	2113743N36	CAP CHIP 27.0 PF 5% COG
C444	2113743N50	CAP CHIP 100 PF 5% COG
C445	2113743N50	CAP CHIP 100 PF 5% COG
C450	2113743N18	CAP CHIP 4.7 PF +/- .25PF COG
C451	2113743N18	CAP CHIP 4.7 PF +/- .25PF COG
C452	2113743N30	CAP CHIP 15.0 PF 5% COG
C453	2113743N34	CAP CHIP 22.0 PF 5% COG
C454	2113743N30	CAP CHIP 15.0 PF 5% COG
C455	2113743N10	CAP CHIP 2.2 PF +/- .25PF COG
C456	2113743N10	CAP CHIP 2.2 PF +/- .25PF COG
C457	2113743N67	CAP CHIP 9.0PF 16V .5PF COG
C458	2113743N67	CAP CHIP 9.0PF 16V .5PF COG
C459	2113743N50	CAP CHIP 100 PF 5% COG
C460	2113743E20	CAP CHIP .10 UF 10%
C461	2113743N13	CAP CHIP 3.0 PF +/- .25PF COG

Ref. Des.	Part Number	Description
C470	2113743N28	CAP CHIP 12.0 PF 5% COG
C471	2113743N13	CAP CHIP 3.0 PF +/- .25PF COG
C472	2113743N50	CAP CHIP 100 PF 5% COG
C473	2113743N50	CAP CHIP 100 PF 5% COG
C474	2113743L29	CAP CHIP 3300 PF 10% X7R
C476	2113743N28	CAP CHIP 12.0 PF 5% COG
C479	2113743N13	CAP CHIP 3.0 PF +/- .25PF COG
C490	2113743N18	CAP CHIP 4.7 PF +/- .25PF COG
C491	2113740F20	CAP CHIP REEL CL1 +/-30 5.1
C5	2113740F24	CAP CHIP REEL CL1 +/-30 7.5
C500	2113743N13	CAP CHIP 3.0 PF +/- .25PF COG
C501	2113743N54	CAP CHIP 150 PF 5% COG
C512	2113743L29	CAP CHIP 3300 PF 10% X7R
C515	2113743L41	CAP CHIP 10000 PF 10% X7R
C516	2113743L17	CAP CHIP 1000 PF 10% X7R
C517	2113743L41	CAP CHIP 10000 PF 10% X7R
C518	2113928N01	CAP CER CHIP 0.1UF 10% 6.3
C519	2113743L41	CAP CHIP 10000 PF 10% X7R
C520	2113928N01	CAP CER CHIP 0.1UF 10% 6.3
C521	2113928N01	CAP CER CHIP 0.1UF 10% 6.3
C522	2113743L41	CAP CHIP 10000 PF 10% X7R
C523	2113743N50	CAP CHIP 100 PF 5% COG
C524	2113743N50	CAP CHIP 100 PF 5% COG



Ref. Des.	Part Number	Description
C525	2113743L41	CAP CHIP 10000 PF 10% X7R
C526	2113743L25	CAP CHIP 2200 PF 10% X7R
C528	2113928N01	CAP CER CHIP 0.1UF 10% 6.3
C529	2113928N01	CAP CER CHIP 0.1UF 10% 6.3
C530	2113743L41	CAP CHIP 10000 PF 10% X7R
C532	2113743L41	CAP CHIP 10000 PF 10% X7R
C533	2113743N50	CAP CHIP 100 PF 5% COG
C534	2113743N50	CAP CHIP 100 PF 5% COG
C535	2113743N46	QAP CHIP 68.0 PF 5% COG
C536	2113928N01	CAP CER CHIP 0.1UF 10% 6.3
C537	2113928N01	CAP CER CHIP 0.1UF 10% 6.3
C539	2113743L41	CAP CHIP 10000 PF 10% X7R
C541	2113928N01	CAP CER CHIP 0.1UF 10% 6.3
C543	2113743L41	CAP CHIP 10000 PF 10% X7R
C547	2113743N24	CAP CHIP 8.2 PF + .5PF COG
C550	2113743E20	CAP CHIP .10 UF 10%
C551	2113743N13	CAP CHIP 3.0 PF +-.25PF COG
C552	2113743L17	CAP CHIP 1000 PF 10% X7R
C553	2113743L50	CAP CHIP 33000 PF 10%
C554	2113743N26	CAP CHIP 10.0 PF 5% COG
C555	2113743N28	CAP CHIP 12.0 PF 5% COG
C556	2113743N44	CAP CHIP 56.0 PF 5% COG
C557	2113743N44	CAP CHIP 56.0 PF 5% COG

Ref. Des.	Part Number	Description
C558	2113928N01	CAP CER CHIP 0.1UF 10% 6.3
C559	2113743L41	CAP CHIP 10000 PF 10% X7R
C560	2113743N36	CAP CHIP 27.0 PF 5% COG
C570	2113743A24	CAP CHIP .330 UF 10% 16V
C571	2113743A24	CAP CHIP .330 UF 10% 16V
C6	2113740F51	CAP CHIP REEL CL1 +/-30 100
C331	2113740L08	CAP CER CHIP 3.9 PF +- 0.1PF
C332	2104801Z10	CAP CER NPO 1.5PF 16V 1005 S
C333	2113740L06	CAP CER CHIP 3.3 PF +- 0.1PF
C335	2113743N24	CAP CHIP 8.2 PF + .5PF COG
C336	2113743N52	CAP CHIP 120 PF 5% COG
C337	2113743L01	CAP CHIP 220 PF 10% X7R
C340	2113743N15	CAP CHIP 3.6PF +/- .25PF COG
C341	2113743N15	CAP CHIP 3.6PF +/- .25PF COG
C4	2113741F49	CAP CHIP CL2 X7R REEL 10000
C40	2113743E20	CAP CHIP .10 UF 10%
C400	2113928N01	CAP CER CHIP 0.1UF 10% 6.3
C401	2113743N50	CAP CHIP 100 PF 5% COG
C404	2113743N50	CAP CHIP 100 PF 5% COG
C410	2113743N18	CAP CHIP 4.7 PF +-.25PF COG
C411	2113743N18	CAP CHIP 4.7 PF +-.25PF COG
C412	2113743N30	CAP CHIP 15.0 PF 5% COG
C413	2113743N34	CAP CHIP 22.0 PF 5% COG
C414	2113743N30	CAP CHIP 15.0 PF 5% COG

Ref. Des.	Part Number	Description
C415	2113743N10	CAP CHIP 2.2 PF +-.25PF COG
C416	2113743N10	CAP CHIP 2.2 PF +-.25PF COG
C417	2113743N67	CAP CHIP 9.0PF 16V .5PF COG
C418	2113743N67	CAP CHIP 9.0PF 16V .5PF COG
C419	2113743E20	CAP CHIP .10 UF 10%
C420	2113743N50	CAP CHIP 100 PF 5% COG
C430	2113743N50	CAP CHIP 100 PF 5% COG
C431	2113743N13	CAP CHIP 3.0 PF +-.25PF COG
C432	2113743N44	CAP CHIP 56.0 PF 5% COG
C433	2113743N25	CAP CHIP 9.1 PF + .5PF COG
C434	2113928C04	CAP CER CHIP 4.7UF 6.3V10%08
C435	2113743N24	CAP CHIP 8.2 PF + .5PF COG
C436	2113743N36	CAP CHIP 27.0 PF 5% COG
C444	2113743N50	CAP CHIP 100 PF 5% COG
C445	2113743N50	CAP CHIP 100 PF 5% COG
C450	2113743N18	CAP CHIP 4.7 PF +-.25PF COG
C451	2113743N18	CAP CHIP 4.7 PF +-.25PF COG
C452	2113743N30	CAP CHIP 15.0 PF 5% COG
C453	2113743N34	CAP CHIP 22.0 PF 5% COG
C454	2113743N30	CAP CHIP 15.0 PF 5% COG
C455	2113743N10	CAP CHIP 2.2 PF +-.25PF COG
C456	2113743N10	CAP CHIP 2.2 PF +-.25PF COG
C457	2113743N67	CAP CHIP 9.0PF 16V .5PF COG
C458	2113743N67	CAP CHIP 9.0PF 16V .5PF COG

Ref. Des.	Part Number	Description
C459	2113743N50	CAP CHIP 100 PF 5% COG
C460	2113743E20	CAP CHIP .10 UF 10%
C461	2113743N13	CAP CHIP 3.0 PF +-.25PF COG
C470	2113743N28	CAP CHIP 12.0 PF 5% COG
C471	2113743N13	CAP CHIP 3.0 PF +-.25PF COG
C472	2113743N50	CAP CHIP 100 PF 5% COG
C473	2113743N50	CAP CHIP 100 PF 5% COG
C474	2113743L29	CAP CHIP 3300 PF 10% X7R
C476	2113743N28	CAP CHIP 12.0 PF 5% COG
C479	2113743N13	CAP CHIP 3.0 PF +-.25PF COG
C490	2113743N18	CAP CHIP 4.7 PF +-.25PF COG
C491	2113740F20	CAP CHIP REEL CL1 +/-30 5.1
C5	2113740F24	CAP CHIP REEL CL1 +/-30 7.5
C500	2113743N13	CAP CHIP 3.0 PF +-.25PF COG
C501	2113743N54	CAP CHIP 150 PF 5% COG
C512	2113743L29	CAP CHIP 3300 PF 10% X7R
C515	2113743L41	CAP CHIP 10000 PF 10% X7R
C516	2113743L17	CAP CHIP 1000 PF 10% X7R
C517	2113743L41	CAP CHIP 10000 PF 10% X7R
C518	2113928N01	CAP CER CHIP 0.1UF 10% 6.3
C519	2113743L41	CAP CHIP 10000 PF 10% X7R
C520	2113928N01	CAP CER CHIP 0.1UF 10% 6.3
C521	2113928N01	CAP CER CHIP 0.1UF 10% 6.3

Ref. Des.	Part Number	Description
C522	2113743L41	CAP CHIP 10000 PF 10% X7R
C523	2113743N50	CAP CHIP 100 PF 5% COG
C524	2113743N50	CAP CHIP 100 PF 5% COG
C525	2113743L41	CAP CHIP 10000 PF 10% X7R
C526	2113743L25	CAP CHIP 2200 PF 10% X7R
C528	2113928N01	CAP CER CHIP 0.1UF 10% 6.3
C529	2113928N01	CAP CER CHIP 0.1UF 10% 6.3
C530	2113743L41	CAP CHIP 10000 PF 10% X7R
C532	2113743L41	CAP CHIP 10000 PF 10% X7R
C533	2113743N50	CAP CHIP 100 PF 5% COG
C534	2113743N50	CAP CHIP 100 PF 5% COG
C535	2113743N46	QAP CHIP 68.0 PF 5% COG
C536	2113928N01	CAP CER CHIP 0.1UF 10% 6.3
C537	2113928N01	CAP CER CHIP 0.1UF 10% 6.3
C539	2113743L41	CAP CHIP 10000 PF 10% X7R
C541	2113928N01	CAP CER CHIP 0.1UF 10% 6.3
C543	2113743L41	CAP CHIP 10000 PF 10% X7R
C547	2113743N24	CAP CHIP 8.2 PF + -.5PF COG
C550	2113743E20	CAP CHIP .10 UF 10%
C551	2113743N13	CAP CHIP 3.0 PF +- .25PF COG
C552	2113743L17	CAP CHIP 1000 PF 10% X7R
C553	2113743L50	CAP CHIP 33000 PF 10%
C554	2113743N26	CAP CHIP 10.0 PF 5% COG

Ref. Des.	Part Number	Description
C555	2113743N28	CAP CHIP 12.0 PF 5% COG
C556	2113743N44	CAP CHIP 56.0 PF 5% COG
C557	2113743N44	CAP CHIP 56.0 PF 5% COG
C558	2113928N01	CAP CER CHIP 0.1UF 10% 6.3
C559	2113743L41	CAP CHIP 10000 PF 10% X7R
C560	2113743N36	CAP CHIP 27.0 PF 5% COG
C570	2113743A24	CAP CHIP .330 UF 10% 16V
C571	2113743A24	CAP CHIP .330 UF 10% 16V
C6	2113740F51	CAP CHIP REEL CL1 +/-30 100
C7	2113740F24	CAP CHIP REEL CL1 +/-30 7.5
C702	2113743N50	CAP CHIP 100 PF 5% COG
C703	2113740F51	CAP CHIP REEL CL1 +/-30 100
C704	2113740F51	CAP CHIP REEL CL1 +/-30 100
C705	2113740F63	CAP CHIP CL1 +/-30 330 5%
C706	2113743N50	CAP CHIP 100 PF 5% COG
C707	2113740F11	CAP CHIP REEL CL1 +/-30 2.2
C708	2113740F11	CAP CHIP REEL CL1 +/-30 2.2
C709	2113740F18	CAP CHIP REEL CL1 +/-30 4.3
C710	2113740F18	CAP CHIP REEL CL1 +/-30 4.3
C711	2113740F11	CAP CHIP REEL CL1 +/-30 2.2
C712	2113740F11	CAP CHIP REEL CL1 +/-30 2.2
C713	2113740F11	CAP CHIP REEL CL1 +/-30 2.2
C714	2113740F11	CAP CHIP REEL CL1 +/-30 2.2

Ref. Des.	Part Number	Description
C715	2113740F51	CAP CHIP REEL CL1 +/-30 100
C8	2113743S01	CAP CER CHIP 1.0 UF 10% 16V
C9	2113743N50	CAP CHIP 100 PF 5% COG
C925	2109720D14	CAP CER CHIP LOW DIST .1 UF
D1	4813833A20	DIODE SCHOTTKY 1A 40V PWRMIT
D101	4802197J83	DUAL SHOTTKY DIODE MBD330DWT
D102	4802197J83	DUAL SHOTTKY DIODE MBD330DWT
D104	4805129M06	DIODE MMBD7000
D2	4813833A20	DIODE SCHOTTKY 1A 40V PWRMIT
D201	4802233J09	DIODE TRIPLE SOT25-RH
D202	4802233J09	DIODE TRIPLE SOT25-RH
D3	4813833A20	DIODE SCHOTTKY 1A 40V PWRMIT
D301	4809877C08	DIODE VARACTOR 1SV279 SMD
D302	4809877C08	DIODE VARACTOR 1SV279 SMD
D303	4809877C08	DIODE VARACTOR 1SV279 SMD
D304	4809877C08	DIODE VARACTOR 1SV279 SMD
D305	4809877C08	DIODE VARACTOR 1SV279 SMD
D306	4809877C08	DIODE VARACTOR 1SV279 SMD
D307	4809877C08	DIODE VARACTOR 1SV279 SMD
D308	4809877C08	DIODE VARACTOR 1SV279 SMD
D309	4809877C08	DIODE VARACTOR 1SV279 SMD
D310	4809877C08	DIODE VARACTOR 1SV279 SMD

Ref. Des.	Part Number	Description
D311	4809877C08	DIODE VARACTOR 1SV279 SMD
D312	4809877C08	DIODE VARACTOR 1SV279 SMD
D313	4809877C08	DIODE VARACTOR 1SV279 SMD
D314	4809877C08	DIODE VARACTOR 1SV279 SMD
D315	4809877C08	DIODE VARACTOR 1SV279 SMD
D316	4809877C08	DIODE VARACTOR 1SV279 SMD
D320	4805218N57	DIODE DUAL
D400	4813825A19	DIODE SCHOTTKY BARRIER SERIE
D411	4809877C13	DIODE VARACTOR ISV305 SMD
D412	4809877C13	DIODE VARACTOR ISV305 SMD
D451	4809877C13	DIODE VARACTOR ISV305 SMD
D452	4809877C13	DIODE VARACTOR ISV305 SMD
D501	4809877C08	DIODE VARACTOR 1SV279 SMD
D550	4809877C13	DIODE VARACTOR ISV305 SMD
D551	4809877C13	DIODE VARACTOR ISV305 SMD
D701	4805656W24	DIODE, PIN RF
D702	4805656W24	DIODE, PIN RF
E1	2405688Z01	INDUCTOR FERRITE BEAD
E101	2405688Z01	INDUCTOR FERRITE BEAD
E105	2480640Z01	SURFACE MOUNT FERRITE BEAD
E5	2480640Z01	SURFACE MOUNT FERRITE BEAD
E501	2480640Z01	SURFACE MOUNT FERRITE BEAD

Ref. Des.	Part Number	Description
E502	2480640Z01	SURFACE MOUNT FERRITE BEAD
E503	2480640Z01	SURFACE MOUNT FERRITE BEAD
E504	2480640Z01	SURFACE MOUNT FERRITE BEAD
E505	2480640Z01	SURFACE MOUNT FERRITE BEAD
E506	2480640Z01	SURFACE MOUNT FERRITE BEAD
E507	2480640Z01	SURFACE MOUNT FERRITE BEAD
E508	2480640Z01	SURFACE MOUNT FERRITE BEAD
E509	2480640Z01	SURFACE MOUNT FERRITE BEAD
E520	2480640Z01	SURFACE MOUNT FERRITE BEAD
E6	2480640Z01	SURFACE MOUNT FERRITE BEAD
E7	2480640Z01	SURFACE MOUNT FERRITE BEAD
F901	6505757V02	FUSE SURFACE MT 2AMP
FL200	9185130D01	FLTR SW CAP 3 POLE BUTTERW
FL490	9185924B01	FILTER, 73.35 MHZ 3-POLE CRY
G1	3905643V01	CONTACT ANT GRD
G12	3905643V01	CONTACT ANT GRD
G2	3905643V01	CONTACT ANT GRD
G3	3905643V01	CONTACT ANT GRD
G6	3905643V01	CONTACT ANT GRD
G7	3905643V01	CONTACT ANT GRD
G8	3905643V01	CONTACT ANT GRD
G9	3905643V01	CONTACT ANT GRD
J1	NOTPLACED	NOTPLACED
J2	0905304Z01	CONN COAXIAL SMT

Ref. Des.	Part Number	Description
L1	2486085A04	COIL, 6.8 UH POWER INDUCTOR
L101	2460591K40	COIL AIR WOUND INDUC 59.71
L103	2480574F01	IND FERRITE CHIP 600 OHM 060
L104	2480574F01	IND FERRITE CHIP 600 OHM 060
L105	2413926H14	IND CHIP 15.0 NH 5%
L106	2413926H13	IND CHIP 12.0 NH 5%
L107	2413926H06	IND CHIP 3.3 NH +/-0.3NH
L108	0662057A17	CHIP RES 47 OHMS 5%
L109	2413926H14	IND CHIP 15.0 NH 5%
L110	2460591B62	COIL AIR WOUND INDUC 11.20
L201	2462587Q20	IND CHIP 2,200 NH 20%
L202	2462587Q20	IND CHIP 2,200 NH 20%
L203	2462587Q20	IND CHIP 2,200 NH 20%
L204	2462587Q20	IND CHIP 2,200 NH 20%
L205	2462587Q47	IND CHIP 1,000 NH 10%
L207	2462587Q47	IND CHIP 1,000 NH 10%
L208	2462587Q20	IND CHIP 2,200 NH 20%
L301	2462587V59	IND CHIP 390 NH 5%
L302	2462587V59	IND CHIP 390 NH 5%
L303	2462587V59	IND CHIP 390 NH 5%
L304	2462587V59	IND CHIP 390 NH 5%
L305	2462587V59	IND CHIP 390 NH 5%
L306	2462587V59	IND CHIP 390 NH 5%
L307	2462587V59	IND CHIP 390 NH 5%
L308	2462587V59	IND CHIP 390 NH 5%
L309	2462587T38	IND CHIP 22NH 5% LOW PRO
L310	2462587T38	IND CHIP 22NH 5% LOW PRO
L311	2462587T37	IND CHIP 18NH 5% LOW PRO

Ref. Des.	Part Number	Description
L312	2462587V59	IND CHIP 390 NH 5%
L313	2462587T40	IND CHIP 33NH 5% LOW PRO
L314	2409377M14	IND CHIP WW 68 NH 5% 1608
L315	2462587V59	IND CHIP 390 NH 5%
L316	2462587V59	IND CHIP 390 NH 5%
L317	2462587V59	IND CHIP 390 NH 5%
L318	2462587V59	IND CHIP 390 NH 5%
L320	2462587T39	IND CHIP 27NH 5% LOW PRO
L321	2409377M17	IND CHIP WW 100 NH 5% 1608
L4	2460591K40	COIL AIR WOUND INDUC 59.71
L410	2462587V35	CHIP IND 120 NH 5% 0805
L411	2460591C63	COIL AIR WOUND INDUC 17.52
L412	2460591C63	COIL AIR WOUND INDUC 17.52
L430	2409154M88	IND CER MLTILYR 10.0NH 1005
L431	2409154M17	IND CER MLTILYR 22.0NH 1005
L432	2409154M50	IND CER MLTILYR 100 NH 1005
L433	2409154M92	IND CER MLTILYR 22.0NH 1005
L434	2409377M10	IND CHIP WW 33NH 5%
L438	2409154M50	IND CER MLTILYR 100 NH 1005
L451	2462587V35	CHIP IND 120 NH 5% 0805
L452	2460591C63	COIL AIR WOUND INDUC 17.52
L453	2460591C63	COIL AIR WOUND INDUC 17.52
L470	2409377M36	IND CHIP WW 220 NH 5% 1608
L473	2462587V37	CHIP IND 180 NH 5% 0805

Ref. Des.	Part Number	Description
L474	2409154M17	IND CER MLTILYR 22.0NH 1005
L475	2404574Z14	IND CHIP WW 270NH 2% 2012 SM
L490	2462587T25	IND CHIP 620NH 5% LOW PRO
L491	2462587T25	IND CHIP 620NH 5% LOW PRO
L501	2405769X05	COIL INDUCTOR
L502	2405769X05	COIL INDUCTOR
L503	2462587Q54	IND CHIP 3,900 NH 10%
L547	2404574Z15	IND CHIP WW 330NH 2% 2012 SM
L550	2462587T21	IND CHIP 330NH 5% LOW PRO
L701	2462587V38	CHIP IND 220 NH 5% 0805
L702	2462587V38	CHIP IND 220 NH 5% 0805
L703	2460591L49	COIL AIR WOUND INDUC 20.53
L704	2460591L49	COIL AIR WOUND INDUC 20.53
L705	2462587V38	CHIP IND 220 NH 5% 0805
L706	2413926N27	COIL 30X60 INDUCTOR 180.0 NH
L707	2413926N27	COIL 30X60 INDUCTOR 180.0 NH
P1	NOTPLACED	NOTPLACED
PCB	8485370D01	PCB RF UHF RNG 1
Q1	4813821A47	TSTR P-CH HDTMOS 20V
Q101	4813824A42	TSTR PNP 50V BIAS RES 10K 10
Q102	4813821A47	TSTR P-CH HDTMOS 20V
Q103	4813824A42	TSTR PNP 50V BIAS RES 10K 10
Q104	4813821A47	TSTR P-CH HDTMOS 20V
Q106	4813824A39	TSTR NPN 50V BIAS RES 22K 22
Q107	5185633C10	MODE 800MHZ RING

Ref. Des.	Part Number	Description
Q108	4805128M12	TSTR SOT BCW 60B (RH)
Q2	4880048M01	TSTR NPN DIG 47K/47K
Q301	4805793Y01	TRANS MINI SOT NPN LOW NOISE
Q302	4805793Y01	TRANS MINI SOT NPN LOW NOISE
Q303	4805793Y01	TRANS MINI SOT NPN LOW NOISE
Q304	4805793Y01	TRANS MINI SOT NPN LOW NOISE
Q305	4809579E16	TSTR MOSFET N-CHAN TN0200T
Q306	4809579E16	TSTR MOSFET N-CHAN TN0200T
Q307	4809579E16	TSTR MOSFET N-CHAN TN0200T
Q308	4809579E16	TSTR MOSFET N-CHAN TN0200T
Q310	4813824A42	TSTR PNP 50V BIAS RES 10K 10
Q311	4813824A39	TSTR NPN 50V BIAS RES 22K 22
Q430	4805585Q19	TRANSISTOR
Q501	4805128M19	TSTR SOT23 MMBTA13 RH
Q502	4805218N63	RF TRANS SOT 323 BFQ67W
Q66	4880048M01	TSTR NPN DIG 47K/47K
Q700	4813821A47	TSTR P-CH HDTMOS 20V
Q701	4880048M01	TSTR NPN DIG 47K/47K
Q99	4813821A47	TSTR P-CH HDTMOS 20V
R1	0662057N23	RES. CHIP 100K 5% 20X40
R101	0662057N23	RES. CHIP 100K 5% 20X40
R103	0662057M58	RES. CHIP 220 5% 20X40
R104	0662057M58	RES. CHIP 220 5% 20X40
R105	0662057N03	RES. CHIP 15K 5% 20X40
R106	0662057M98	RES. CHIP 10K 5% 20X40
R107	0662057M90	RES. CHIP 4700 5% 20X40

Ref. Des.	Part Number	Description
R108	0662057M90	RES. CHIP 4700 5% 20X40
R109	0662057M50	RES. CHIP 100 5% 20X40
R110	0662057M50	RES. CHIP 100 5% 20X40
R111	0662057N39	RES. CHIP 470K 5% 20X40
R112	0662057N23	RES. CHIP 100K 5% 20X40
R113	0662057N23	RES. CHIP 100K 5% 20X40
R114	0662057N23	RES. CHIP 100K 5% 20X40
R115	0662057M74	RES. CHIP 1000 5% 20X40
R117	0662057M26	RES. CHIP 10 5% 20X40
R118	0662057M50	RES. CHIP 100 5% 20X40
R119	0662057M50	RES. CHIP 100 5% 20X40
R120	0662057M50	RES. CHIP 100 5% 20X40
R121	0662057M50	RES. CHIP 100 5% 20X40
R126	0662057M98	RES. CHIP 10K 5% 20X40
R127	0662057N03	RES. CHIP 15K 5% 20X40
R128	0662057M98	RES. CHIP 10K 5% 20X40
R129	0662057N15	RES. CHIP 47K 5% 20X40
R131	0662057M98	RES. CHIP 10K 5% 20X40
R132	0662057M98	RES. CHIP 10K 5% 20X40
R201	0662057N11	RES. CHIP 33K 5% 20X40
R202	0662057M81	RES. CHIP 2000 5% 20X40
R204	0662057N17	RES. CHIP 56K 5% 20X40
R205	0662057N13	RES. CHIP 39K 5% 20X40
R207	0662057M40	RES. CHIP 39 5% 20X40
R208	0662057N11	RES. CHIP 33K 5% 20X40
R209	0662057M98	RES. CHIP 10K 5% 20X40
R210	0662057M64	RES. CHIP 390 5% 20X40
R211	0662057M74	RES. CHIP 1000 5% 20X40
R212	0662057M52	RES. CHIP 120 5% 20X40
R213	0662057M98	RES. CHIP 10K 5% 20X40
R214	0662057M74	RES. CHIP 1000 5% 20X40
R215	0662057M98	RES. CHIP 10K 5% 20X40
R216	0662057M96	RES. CHIP 8200 5% 20X40

Ref. Des.	Part Number	Description
R217	0662057M76	RES. CHIP 1200 5% 20X40
R220	NOTPLACED	NOTPLACED
R301	0662057N06	RES. CHIP 20K 5% 20X40
R302	0662057M58	RES. CHIP 220 5% 20X40
R303	0662057N07	RES. CHIP 22K 5% 20X40
R304	0662057M34	RES. CHIP 22 5% 20X40
R305	0662057N16	RES. CHIP 51K 5% 20X40
R306	0662057M32	RES. CHIP 18 5% 20X40
R307	0662057M61	RES. CHIP 300 5% 20X40
R308	0662057M61	RES. CHIP 300 5% 20X40
R309	0662057N06	RES. CHIP 20K 5% 20X40
R310	0662057M58	RES. CHIP 220 5% 20X40
R311	0662057N07	RES. CHIP 22K 5% 20X40
R312	0662057M38	RES. CHIP 33 5% 20X40
R313	0662057M34	RES. CHIP 22 5% 20X40
R314	0662057M34	RES. CHIP 22 5% 20X40
R315	0662057M42	RES. CHIP 47 5% 20X40
R316	0662057N16	RES. CHIP 51K 5% 20X40
R317	0662057N06	RES. CHIP 20K 5% 20X40
R318	0662057M58	RES. CHIP 220 5% 20X40
R319	0662057N07	RES. CHIP 22K 5% 20X40
R320	0662057M34	RES. CHIP 22 5% 20X40
R321	0662057M62	RES. CHIP 330 5% 20X40
R322	0662057N16	RES. CHIP 51K 5% 20X40
R323	0662057N06	RES. CHIP 20K 5% 20X40
R324	0662057M58	RES. CHIP 220 5% 20X40
R325	0662057N07	RES. CHIP 22K 5% 20X40
R326	0662057M34	RES. CHIP 22 5% 20X40
R327	0662057N16	RES. CHIP 51K 5% 20X40
R332	0662057M92	RES. CHIP 5600 5% 20X40
R333	0662057M58	RES. CHIP 220 5% 20X40
R400	0662057N23	RES. CHIP 100K 5% 20X40
R411	0662057M98	RES. CHIP 10K 5% 20X40

Ref. Des.	Part Number	Description
R412	0662057M98	RES. CHIP 10K 5% 20X40
R430	0662057M58	RES. CHIP 220 5% 20X40
R431	0662057M82	RES. CHIP 2200 5% 20X40
R432	0662057M82	RES. CHIP 2200 5% 20X40
R433	0662057M94	RES. CHIP 6800 5% 20X40
R434	0662057M70	DES. CHIP 680 5% 20X40
R451	0662057M98	RES. CHIP 10K 5% 20X40
R452	0662057M98	RES. CHIP 10K 5% 20X40
R470	0662057M59	RES CHIP 240 5% 20X40
R471	0662057M48	RES. CHIP 82 5% 20X40
R472	0662057M32	RES. CHIP 18 5% 20X40
R473	0662057M32	RES. CHIP 18 5% 20X40
R501	0662057N23	RES. CHIP 100K 5% 20X40
R502	0662057M56	RES. CHIP 180 5% 20X40
R503	0662057M98	RES. CHIP 10K 5% 20X40
R504	0662057M98	RES. CHIP 10K 5% 20X40
R506	0662057M98	RES. CHIP 10K 5% 20X40
R508	0662057M62	RES. CHIP 330 5% 20X40
R509	0662057M42	RES. CHIP 47 5% 20X40
R510	0662057N23	RES. CHIP 100K 5% 20X40
R511	0662057N23	RES. CHIP 100K 5% 20X40
R512	0662057M98	RES. CHIP 10K 5% 20X40
R513	0662057M98	RES. CHIP 10K 5% 20X40
R514	0662057M64	RES. CHIP 390 5% 20X40
R551	0662057M81	RES. CHIP 2000 5% 20X40
R552	0662057M95	RES. CHIP 7500 5% 20X40
R6	0662057M98	RES. CHIP 10K 5% 20X40
R7	0662057M98	RES. CHIP 10K 5% 20X40
R702	0662057A37	CHIP RES 330 OHMS 5%
R703	0662057M50	RES. CHIP 100 5% 20X40
R704	0662057N23	RES. CHIP 100K 5% 20X40
R706	0662057N23	RES. CHIP 100K 5% 20X40
R719	0662057M78	RES. CHIP 1500 5% 20X40

Ref. Des.	Part Number	Description
R720	0662057N23	RES. CHIP 100K 5% 20X40
SH201	2685787B01	SHLD FRAC-N
SH202	2685787B01	SHLD FRAC-N
SH301	2685297D01	SHLD VCO
SH302	2685298D01	SHLD VCO BUFFER
SH401	2685627A02	SHLD DUAL INDUCTOR
SH402	2685627A02	SHLD DUAL INDUCTOR
SH403	2685882A01	SHLD VCO TANK
SH501	2685298D01	SHLD VCO BUFFER
SH700	2685762D02	SHIELD HARMONIC FILTER
T471	2580541Z02	BALUN TRANSFORMER (NEW)
T472	2580541Z02	BALUN TRANSFORMER (NEW)
T473	2505515V07	XFMR JEDI MIXER 25:1
TH1	NOTPLACED	NOTPLACED
U1	5185353D13	IC MINI SO-8 HI PRECISION RE
U101	5185633C23	MODULE DIRECT COUPLER
U102	5185130C65	IC VHF/UHF/800 MHZ LDMOS DRI
U103	5185963A15	IC TEMPATURE SENSOR 1M50C
U104	5185765B26	IC PWR CTRL IN MOS20
U105	5185368C19	IC QUAD 10 BIT A/D CONV
U106	5185963A60	OP AMP IC
U2	5185353D14	IC SOT23-5 HI PRECISION REG
U201	51863580	IC ANALOG OP-AMP CLC450
U202	5185963A27	IC TESTED AT25016 48 PIN GFP
U203	5185368C83	IC 12 BIT DAC
U3	5185353D14	IC SOT23-5 HI PRECISION REG

Ref. Des.	Part Number	Description
U300	5105750U54	IC PKG DIE VCO BUFFER
U4	5105462G78	IC EEPROM 16K SPEI CMOS
U401	5185130C83	IC 15DB DIGITAL ATTEUATOR SO
U404	5185143E12	IC INVERTER DUAL SC70
U470	5185130C91	IC MIXER RF SOIC 10
U500	5185963A85	IC-ABACUS III-LP
VR1	4813830A33	DIODE 20V 5% 225MW MMBZ5250B
VR2	4813830A15	DIODE 5.6V 5% 225MW MMBZ5232
VR3	4805656W45	DIODE TRANSIENT VOLTAGE SUPP
W02	NOTPLACED	NOTPLACED
W021	NOTPLACED	NOTPLACED
W1	NOTPLACED	NOTPLACED
W10	NOTPLACED	NOTPLACED
W11	NOTPLACED	NOTPLACED
W12	NOTPLACED	NOTPLACED
W13	NOTPLACED	NOTPLACED
W14	NOTPLACED	NOTPLACED
W15	NOTPLACED	NOTPLACED
W16	NOTPLACED	NOTPLACED
W17	NOTPLACED	NOTPLACED
W18	NOTPLACED	NOTPLACED
W19	NOTPLACED	NOTPLACED
W2	NOTPLACED	NOTPLACED
W20	NOTPLACED	NOTPLACED
W21	NOTPLACED	NOTPLACED
W22	NOTPLACED	NOTPLACED
W23	NOTPLACED	NOTPLACED
W3	NOTPLACED	NOTPLACED
W4	NOTPLACED	NOTPLACED
W5	NOTPLACED	NOTPLACED

Ref. Des.	Part Number	Description
W6	NOTPLACED	NOTPLACED
W7	NOTPLACED	NOTPLACED
W8	NOTPLACED	NOTPLACED
W9	NOTPLACED	NOTPLACED
Y200	4802245J68	OSC REF 16.8 MHZ 1.5 PPM

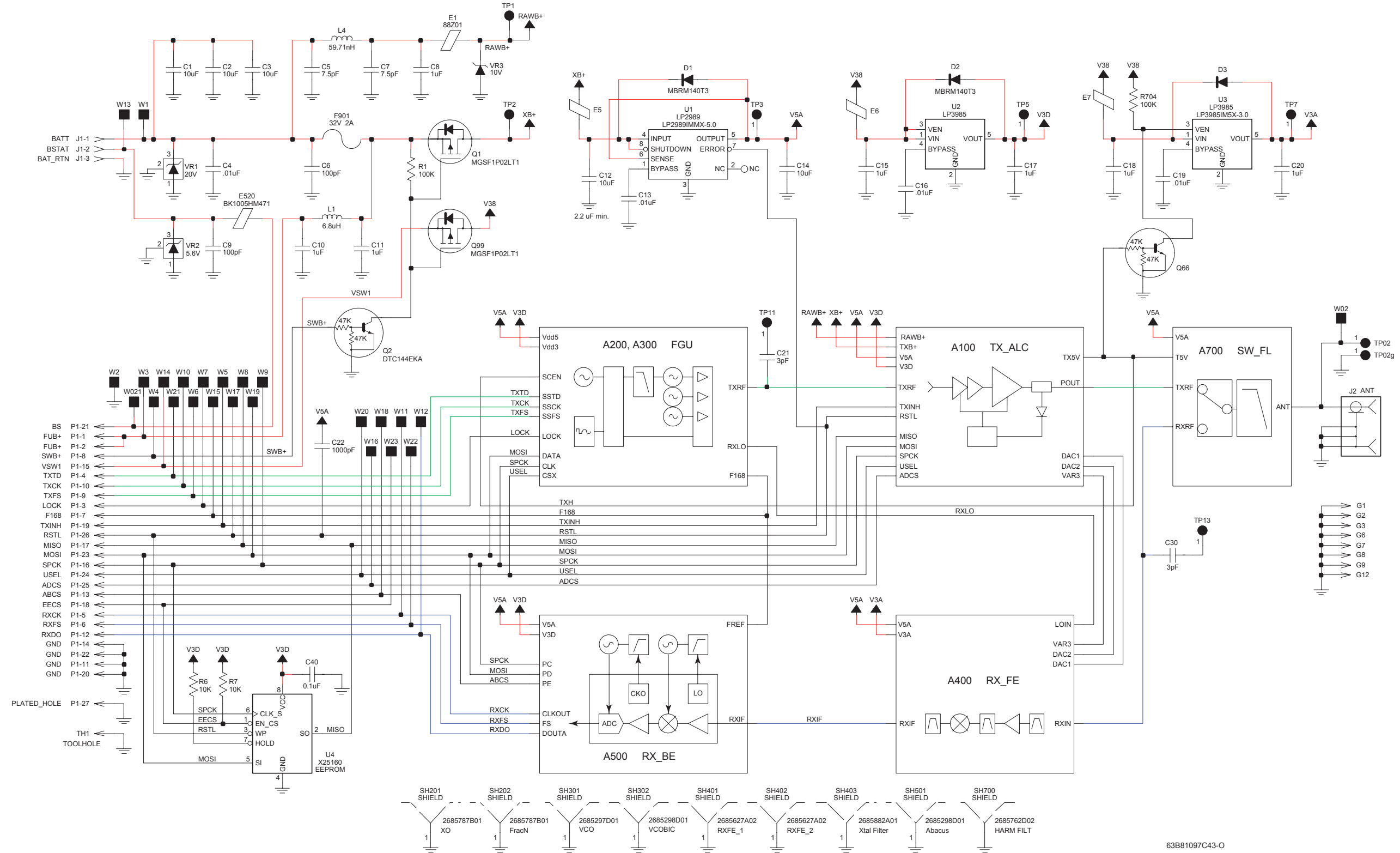

Figure 8-40. NLE4278A UHF Range 1 Transceiver (RF) Board Overall Circuit Schematic

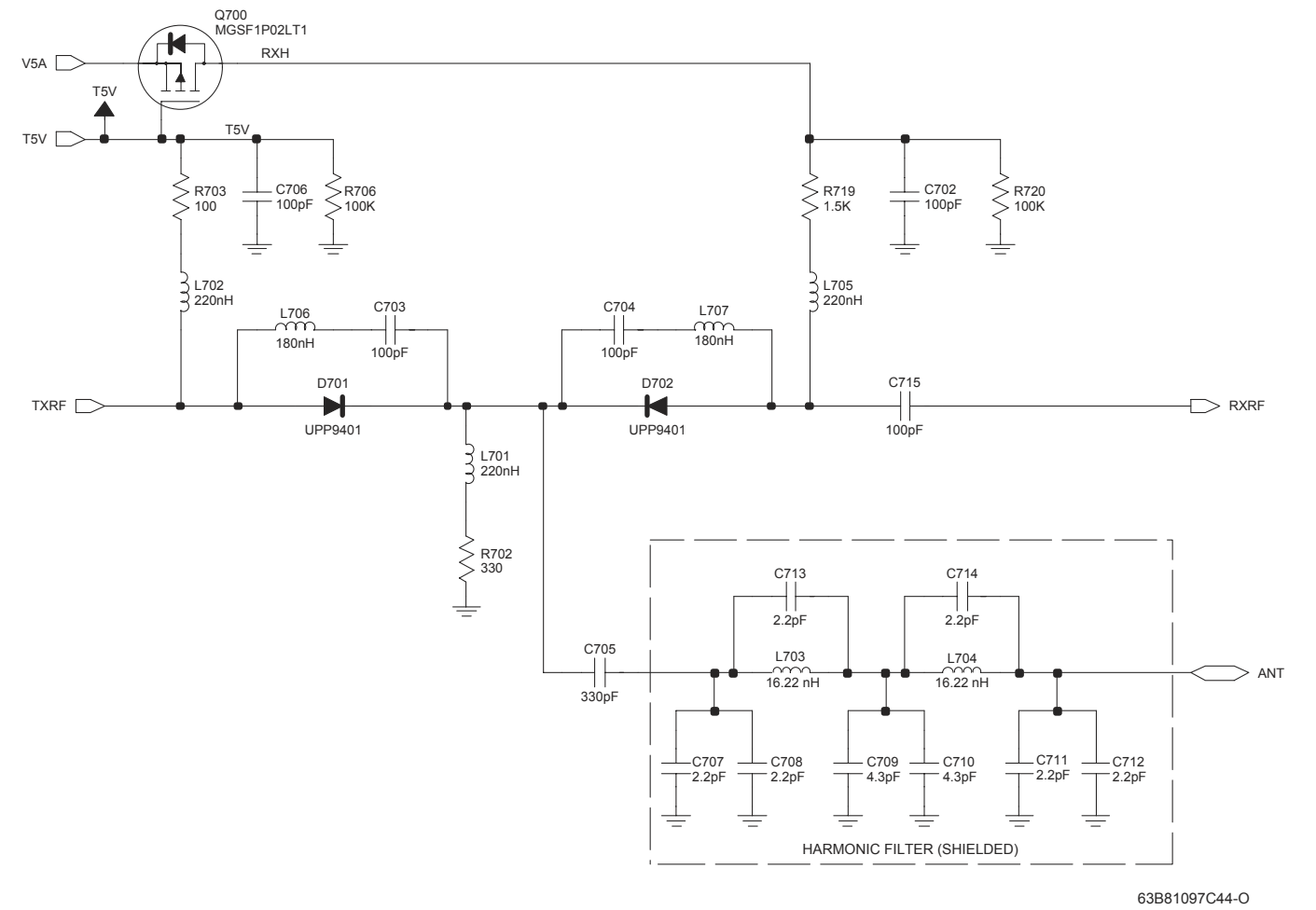

Figure 8-41. NLE4278A UHF Range 1 Antenna Switch and Harmonic Filter Circuits

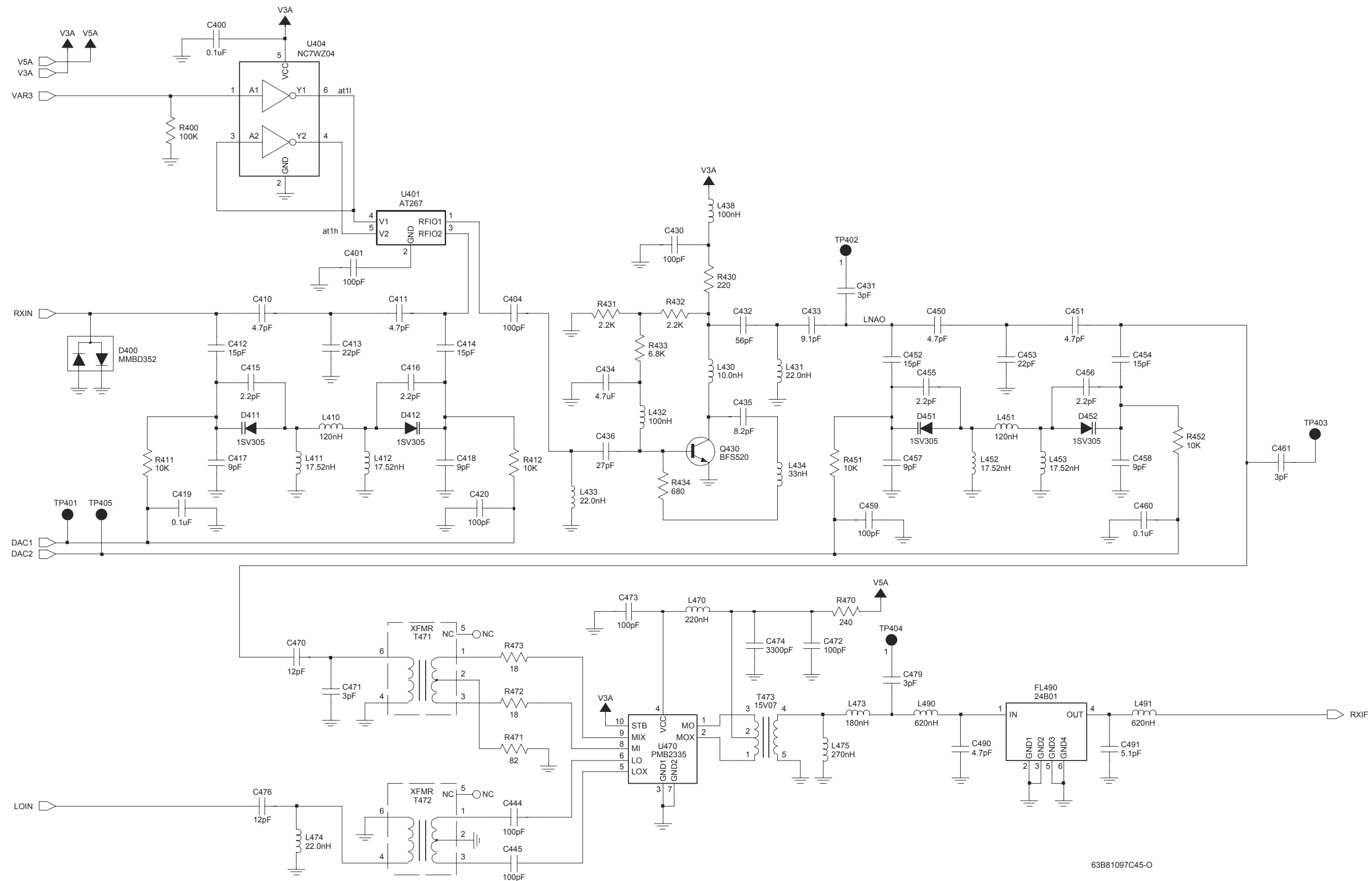

Figure 8-42. NLE4278A UHF Range 1 Receiver Front End Circuit



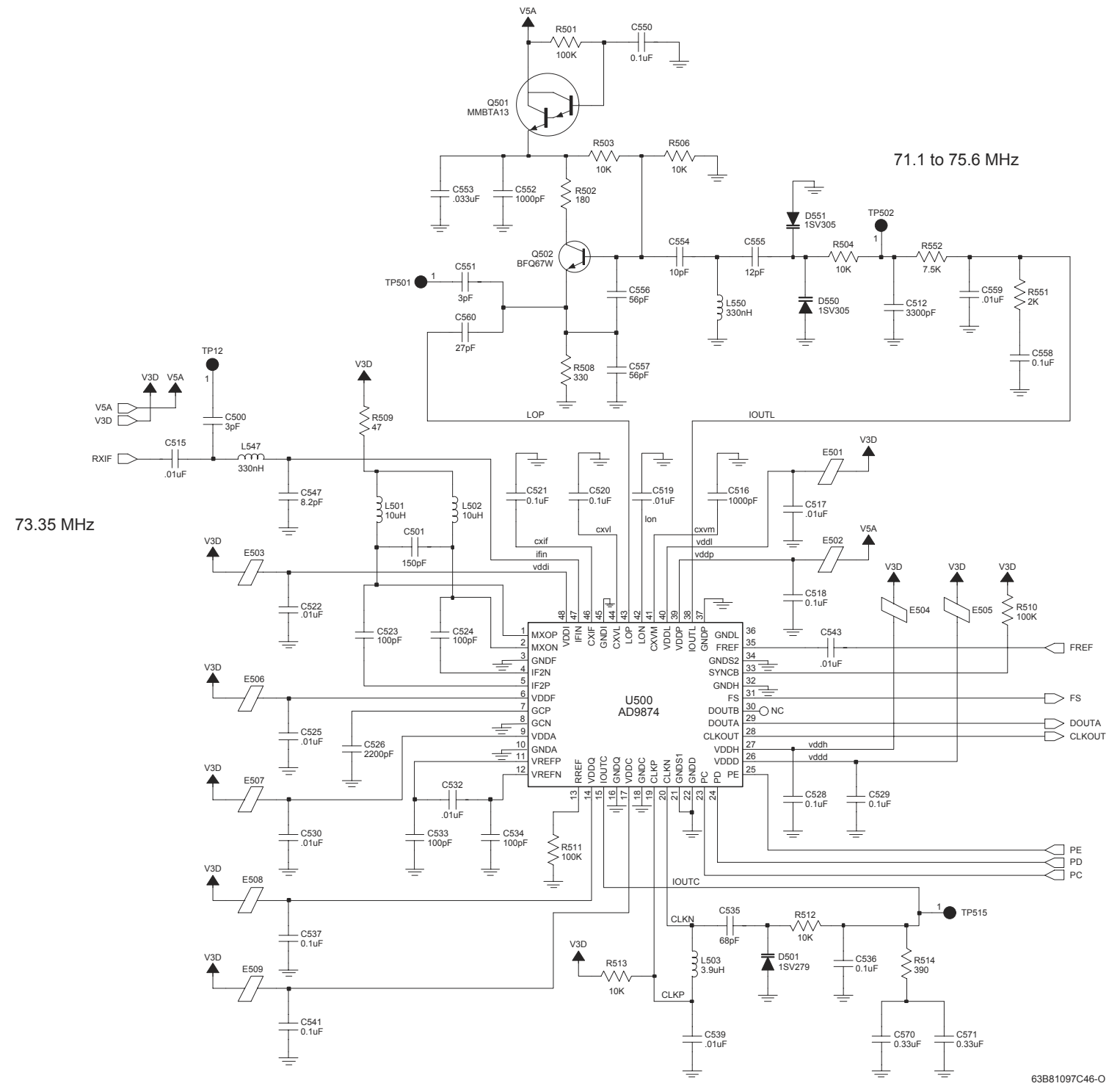
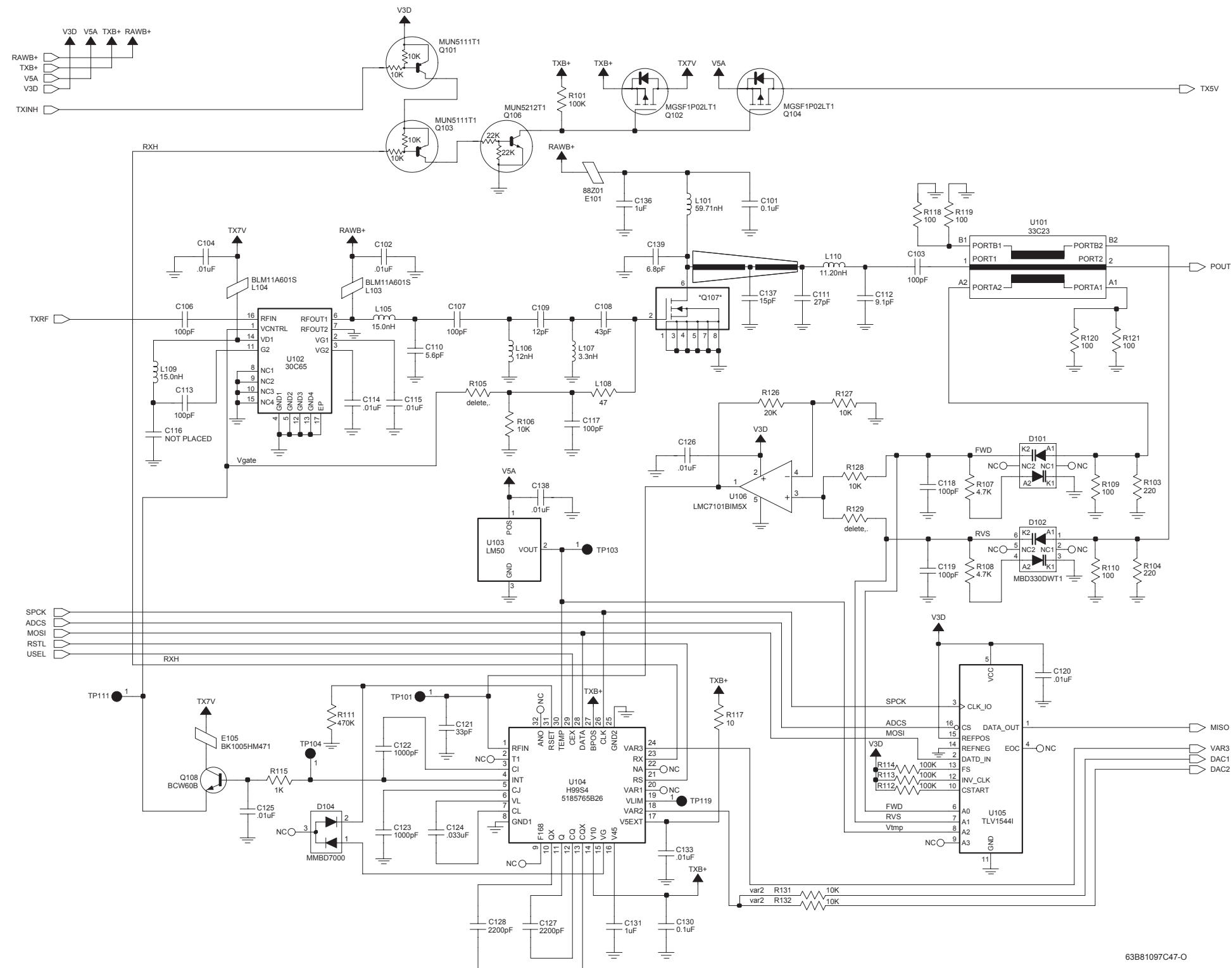
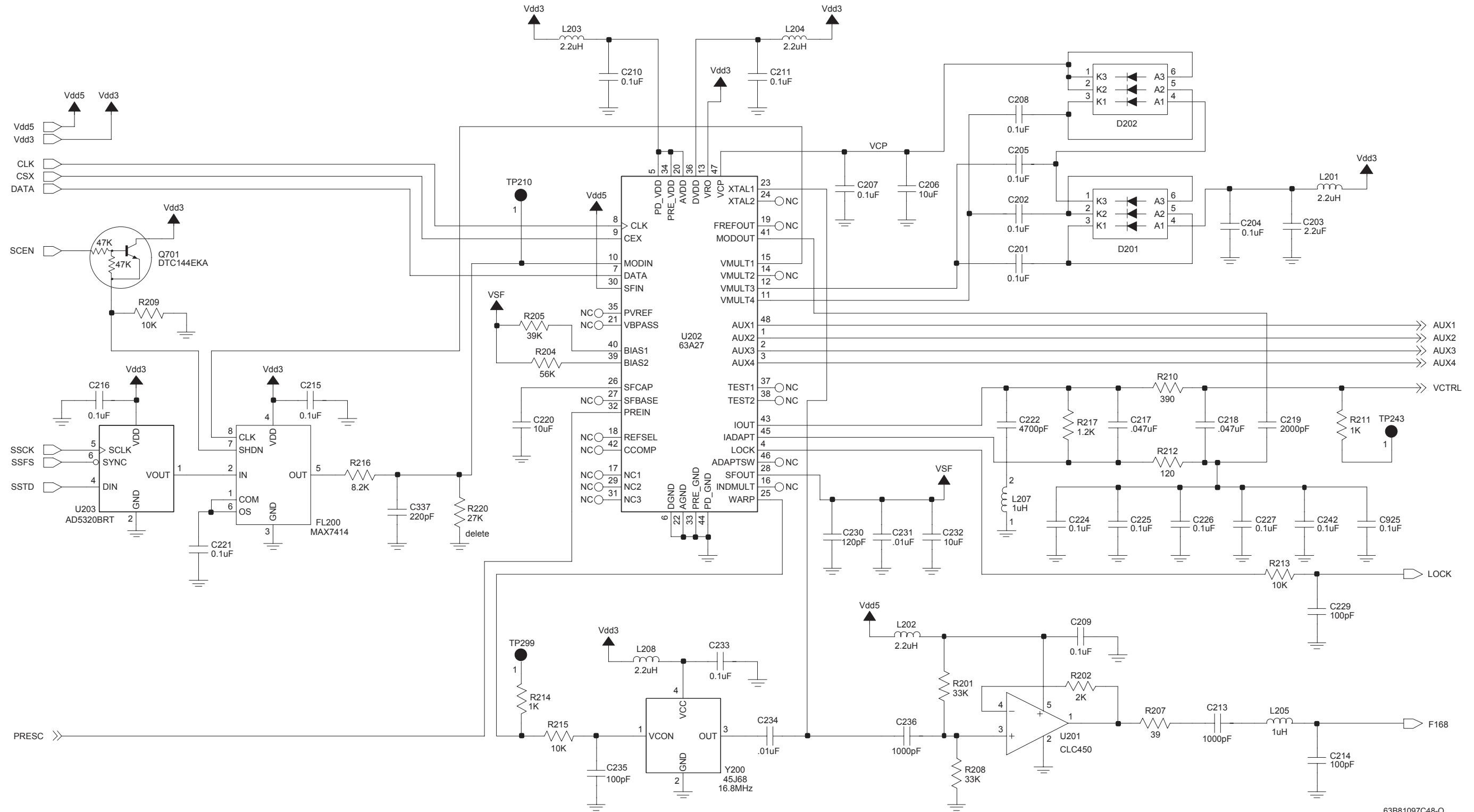

Figure 8-43. NLE4278A UHF Range 1 Receiver Back End Circuit



63B81097C47-O

Figure 8-44. NLE4278A UHF Range 1 Transmitter Power Amplifier and Automatic Level Control Circuit



63B81097C48-O

Figure 8-45. NLE4278A UHF Range 1 Frequency Unit (Synthesizer) Circuit

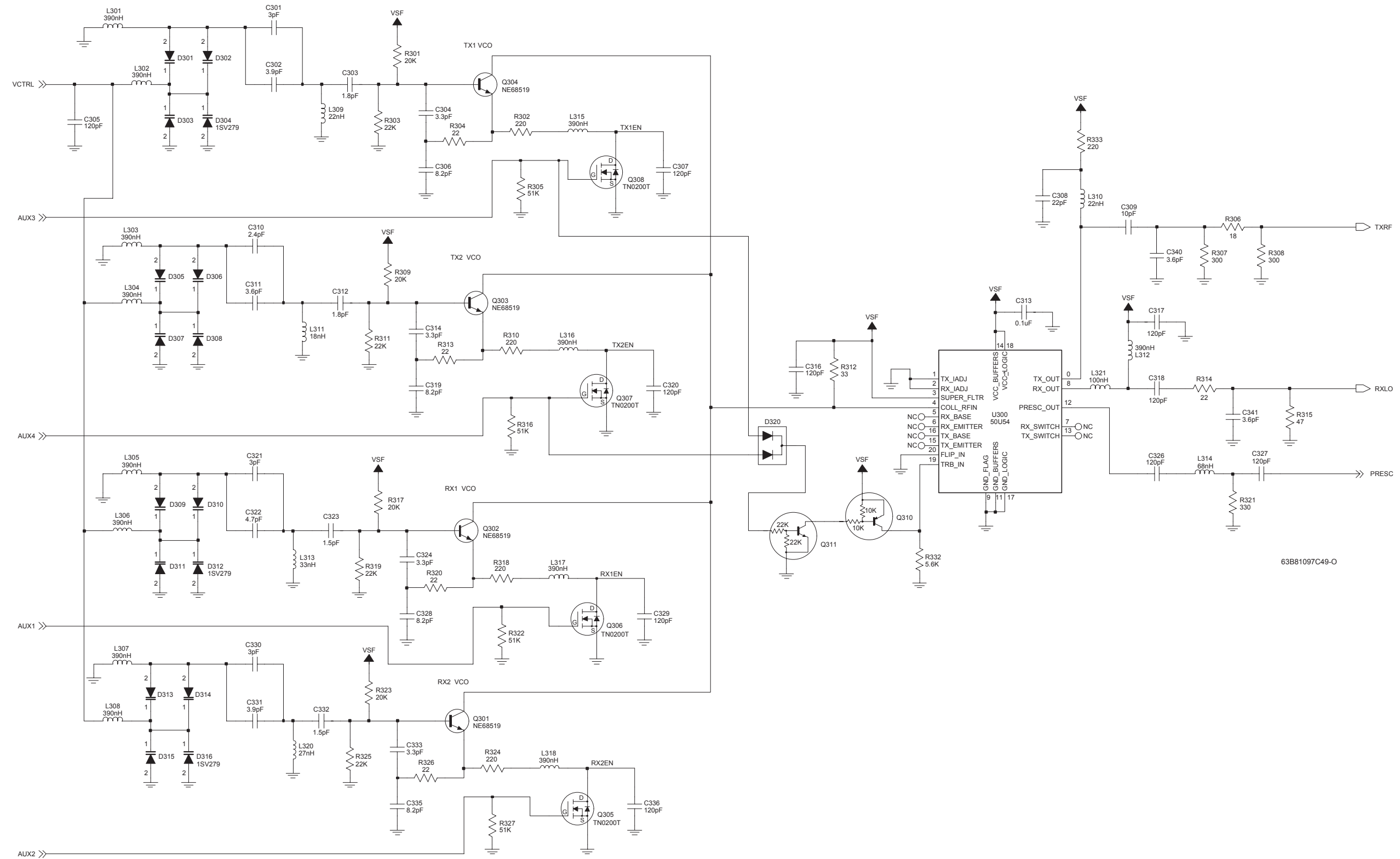

63B81097C49-O

Figure 8-46. NLE4278A UHF Range 1 Frequency Generation Unit (VCO) Circuit

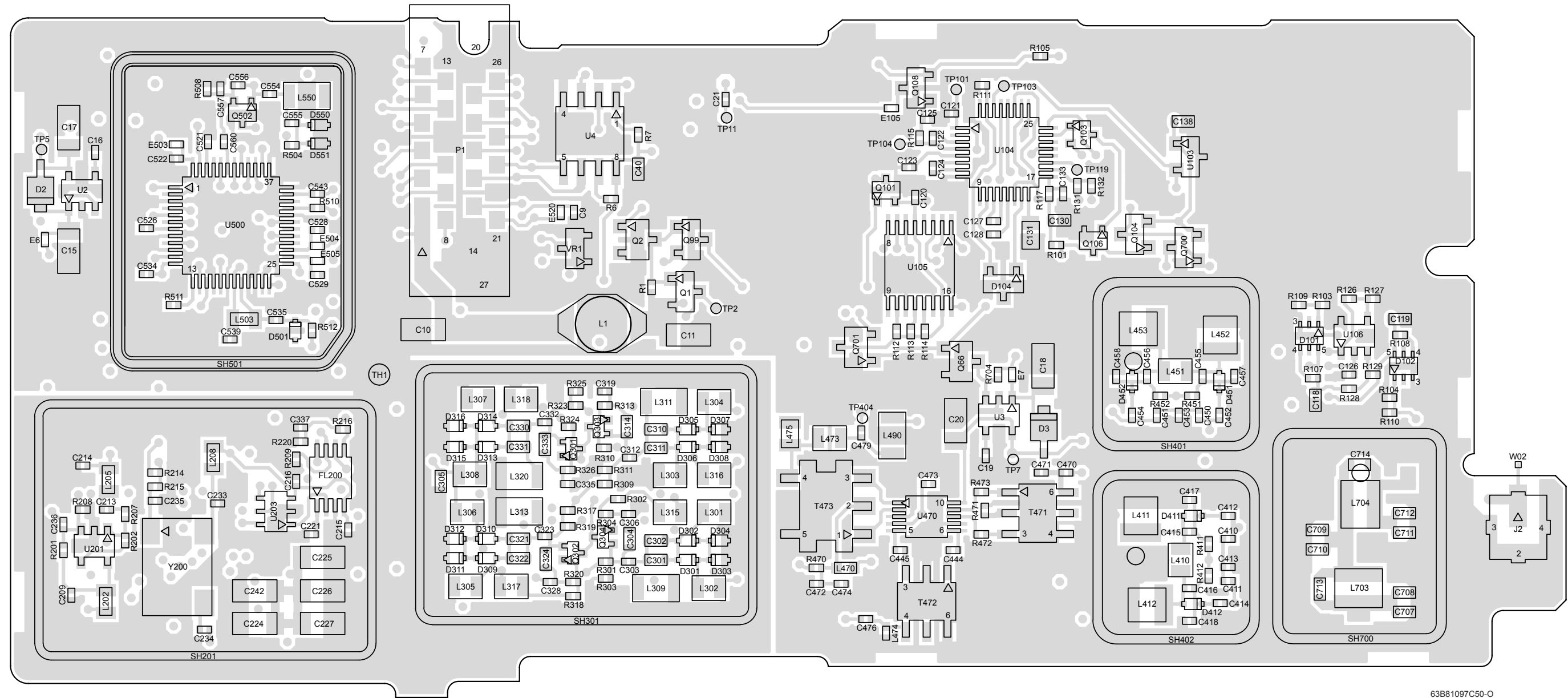

63B81097C50-O

Figure 8-47. NLE4278A UHF Range 1 Transceiver (RF) Board Layout—Side 1

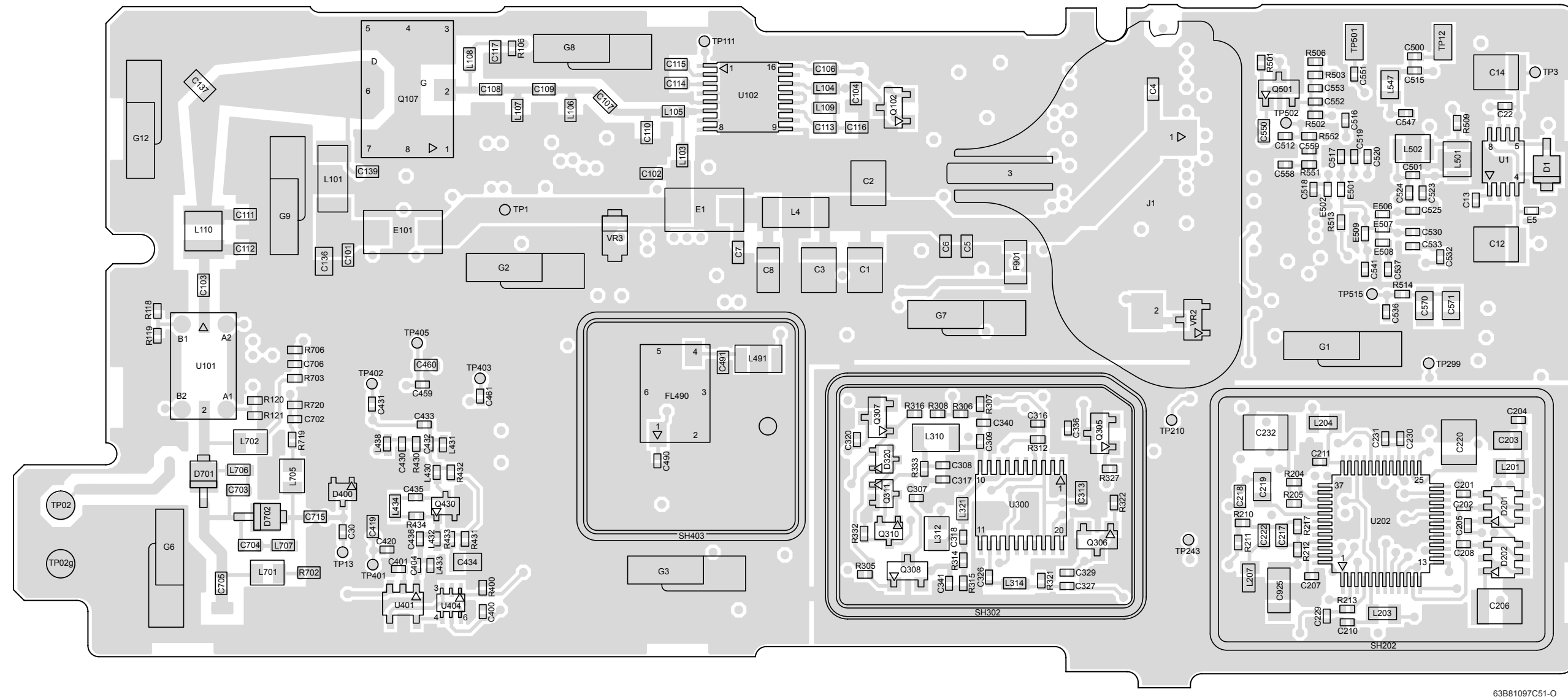

63B81097C51-O

Figure 8-48. NLE4278A UHF Range 1 Transceiver (RF) Board Layout—Side 2

NLE4278A UHF Range 1 Navy Low-Power  
Parts List

Ref. Des.	Part Number	Description
C1	2113743T19	CAP 10UF 16V CER 3225 X5R
C10	2113743S01	CAP CER CHIP 1.0 UF 10% 16V
C101	2113743E20	CAP CHIP .10 UF 10%
C102	2113741F49	CAP CHIP CL2 X7R REEL 10000
C103	2113740F51	CAP CHIP REEL CL1 +/-30 100
C104	2113741F49	CAP CHIP CL2 X7R REEL 10000
C106	2113740F51	CAP CHIP REEL CL1 +/-30 100
C107	2113740F51	CAP CHIP REEL CL1 +/-30 100
C108	2113740F42	CAP CHIP REEL CL1 +/-30 43
C109	2113740F29	CAP CHIP REEL CL1 +/-30 12
C11	2113743S01	CAP CER CHIP 1.0 UF 10% 16V
C110	2113740F21	CAP CHIP REEL CL1 +/-30 5.6
C111	2113740F37	CAP CHIP REEL CL1 +/-30 27
C112	2113740F26	CAP CHIP REEL CL1 +/-30 9.1
C113	2113740F51	CAP CHIP REEL CL1 +/-30 100
C114	2113741F49	CAP CHIP CL2 X7R REEL 10000
C115	2113741F49	CAP CHIP CL2 X7R REEL 10000
C116	2113740F27	CAP CHIP REEL CL1 +/-30 10
C117	2113740F51	CAP CHIP REEL CL1 +/-30 100
C118	2113740F51	CAP CHIP REEL CL1 +/-30 100
C119	2113740F51	CAP CHIP REEL CL1 +/-30 100
C12	2113743T19	CAP 10UF 16V CER 3225 X5R

Ref. Des.	Part Number	Description
C120	2113743L41	CAP CHIP 10000 PF 10% X7R
C121	2113743N38	CAP CHIP 33.0 PF 5% COG
C122	2113743L17	CAP CHIP 1000 PF 10% X7R
C123	2113743L17	CAP CHIP 1000 PF 10% X7R
C124	2113743L50	CAP CHIP 33000 PF 10%
C125	2113743L41	CAP CHIP 10000 PF 10% X7R
C126	2113743L41	CAP CHIP 10000 PF 10% X7R
C127	2113743L25	CAP CHIP 2200 PF 10% X7R
C128	2113743L25	CAP CHIP 2200 PF 10% X7R
C13	2113743L41	CAP CHIP 10000 PF 10% X7R
C130	2113743E20	CAP CHIP .10 UF 10%
C131	2113743A31	CAP CHIP 1.0 UF 10% X7R
C133	2113743L41	CAP CHIP 10000 PF 10% X7R
C136	2113743A31	CAP CHIP 1.0 UF 10% X7R
C137	2113742H43	CAP 15.0 PF 5%
C138	2113741F49	CAP CHIP CL2 X7R REEL 10000
C139	2113740F23	CAP CHIP REEL CL1 +/-30 6.8
C14	2113743T19	CAP 10UF 16V CER 3225 X5R
C15	2113743S01	CAP CER CHIP 1.0 UF 10% 16V
C16	2113743L41	CAP CHIP 10000 PF 10% X7R
C17	2113743S01	CAP CER CHIP 1.0 UF 10% 16V
C18	2113743S01	CAP CER CHIP 1.0 UF 10% 16V
C19	2113743L41	CAP CHIP 10000 PF 10% X7R
C2	2113743T19	CAP 10UF 16V CER 3225 X5R
C20	2113743S01	CAP CER CHIP 1.0 UF 10% 16V

Ref. Des.	Part Number	Description
C201	2113743M24	CAP CHIP 100000 PF +80-20% Y5V
C202	2113743M24	CAP CHIP 100000 PF +80-20% Y5V
C203	2113743F18	CAP CHIP 2.2 UF 16V +80-20%
C204	2113743M24	CAP CHIP 100000 PF +80-20% Y5V
C205	2113743M24	CAP CHIP 100000 PF +80-20% Y5V
C206	2113743T19	CAP 10UF 16V CER 3225 X5R
C207	2113743M24	CAP CHIP 100000 PF +80-20% Y5V
C208	2113743M24	CAP CHIP 100000 PF +80-20% Y5V
C209	2113743M24	CAP CHIP 100000 PF +80-20% Y5V
C21	2113743N13	CAP CHIP 3.0 PF +/-25PF COG
C210	2113743M24	CAP CHIP 100000 PF +80-20% Y5V
C211	2113743M24	CAP CHIP 100000 PF +80-20% Y5V
C213	2113743L17	CAP CHIP 1000 PF 10% X7R
C214	2113743N50	CAP CHIP 100 PF 5% COG
C215	2113743M24	CAP CHIP 100000 PF +80-20% Y5V
C216	2113743M24	CAP CHIP 100000 PF +80-20% Y5V
C217	2113743E12	CAP CHIP .047 UF 10% X7R
C218	2113743E12	CAP CHIP .047 UF 10% X7R
C219	2109720D20	CAP CHIP LOW DIST 2000 SOV
C22	2113743L17	CAP CHIP 1000 PF 10% X7R
C220	2113743T19	CAP 10UF 16V CER 3225 X5R
C221	2113743M24	CAP CHIP 100000 PF +80-20% Y5V
C222	2113741F41	CAP CHIP CL2 X7R REEL 4700

Ref. Des.	Part Number	Description
C224	2109720D14	CAP CER CHIP LOW DIST .1 UF
C225	2109720D14	CAP CER CHIP LOW DIST .1 UF
C226	2109720D14	CAP CER CHIP LOW DIST .1 UF
C227	2109720D14	CAP CER CHIP LOW DIST .1 UF
C229	2113743N50	CAP CHIP 100 PF 5% COG
C230	2113743N52	CAP CHIP 120 PF 5% COG
C231	2113743L41	CAP CHIP 10000 PF 10% X7R
C232	2113743T19	CAP 10UF 16V CER 3225 X5R
C233	2113743M24	CAP CHIP 100000 PF +80-20% Y5V
C234	2113743L41	CAP CHIP 10000 PF 10% X7R
C235	2113743N50	CAP CHIP 100 PF 5% COG
C236	2113743L17	CAP CHIP 1000 PF 10% X7R
C242	2109720D14	CAP CER CHIP LOW DIST .1 UF
C3	2113743T19	CAP 10UF 16V CER 3225 X5R
C30	2113743N13	CAP CHIP 3.0 PF +/-25PF COG
C301	2113740L05	CAP CER CHIP 3.0 PF +/-0.1PF
C302	2113740L08	CAP CER CHIP 3.9 PF +/-0.1PF
C303	2104801Z12	CAP CER NPO 1.8PF 16V 1005 SMD
C304	2113740L06	CAP CER CHIP 3.3 PF +/-0.1PF
C305	2113740F53	CAP CHIP REEL CL1 +/-30 120
C306	2113743N24	CAP CHIP 8.2 PF +/-5PF COG
C307	2113743N52	CAP CHIP 120 PF 5% COG
C308	2113743N34	CAP CHIP 22.0 PF 5% COG
C309	2113743N26	CAP CHIP 10.0 PF 5% COG
C310	2113740L03	CAP CER CHIP 2.4 PF +/-0.1PF

Ref. Des.	Part Number	Description
C311	2113740L07	CAP CER CHIP 3.6 PF +- 0.1PF
C312	2104801Z12	CAP CER NPO 1.8PF 16V 1005 SMD
C313	2113743E20	CAP CHIP .10 UF 10%
C314	2113740L06	CAP CER CHIP 3.3 PF +- 0.1PF
C316	2113743N52	CAP CHIP 120 PF 5% COG
C317	2113743N52	CAP CHIP 120 PF 5% COG
C318	2113743N52	CAP CHIP 120 PF 5% COG
C319	2113743N24	CAP CHIP 8.2 PF + -.5PF COG
C320	2113743N52	CAP CHIP 120 PF 5% COG
C321	2113740L05	CAP CER CHIP 3.0 PF +- 0.1PF
C322	2113740L10	CAP CER CHIP 4.7 PF +- 0.1PF
C323	2104801Z10	CAP CER NPO 1.5PF 16V 1005 SMD
C324	2113740L06	CAP CER CHIP 3.3 PF +- 0.1PF
C326	2113743N52	CAP CHIP 120 PF 5% COG
C327	2113743N52	CAP CHIP 120 PF 5% COG
C328	2113743N24	CAP CHIP 8.2 PF + -.5PF COG
C329	2113743N52	CAP CHIP 120 PF 5% COG
C330	2113740L05	CAP CER CHIP 3.0 PF +- 0.1PF
C331	2113740L08	CAP CER CHIP 3.9 PF +- 0.1PF
C332	2104801Z10	CAP CER NPO 1.5PF 16V 1005 SMD
C333	2113740L06	CAP CER CHIP 3.3 PF +- 0.1PF
C335	2113743N24	CAP CHIP 8.2 PF + -.5PF COG
C336	2113743N52	CAP CHIP 120 PF 5% COG
C337	2113743L01	CAP CHIP 220 PF 10% X7R
C340	2113743N15	CAP CHIP 3.6 PF +- .25PF COG
C341	2113743N15	CAP CHIP 3.6 PF +- .25PF COG
C4	2113741F49	CAP CHIP CL2 X7R REEL 10000

Ref. Des.	Part Number	Description
C40	2113743E20	CAP CHIP .10 UF 10%
C400	2113928N01	CAP CER CHIP 0.1UF 10% 6.3
C401	2113743N50	CAP CHIP 100 PF 5% COG
C404	2113743N50	CAP CHIP 100 PF 5% COG
C410	2113743N18	CAP CHIP 4.7 PF +- .25PF COG
C411	2113743N18	CAP CHIP 4.7 PF +- .25PF COG
C412	2113743N30	CAP CHIP 15.0 PF 5% COG
C413	2113743N34	CAP CHIP 22.0 PF 5% COG
C414	2113743N30	CAP CHIP 15.0 PF 5% COG
C415	2113743N10	CAP CHIP 2.2 PF +- .25PF COG
C416	2113743N10	CAP CHIP 2.2 PF +- .25PF COG
C417	2113743N67	CAP CHIP 9.0PF 16V .5PF COG
C418	2113743N67	CAP CHIP 9.0PF 16V .5PF COG
C419	2113743E20	CAP CHIP .10 UF 10%
C420	2113743N50	CAP CHIP 100 PF 5% COG
C430	2113743N50	CAP CHIP 100 PF 5% COG
C431	2113743N13	CAP CHIP 3.0 PF +- .25PF COG
C432	2113743N44	CAP CHIP 56.0 PF 5% COG
C433	2113743N25	CAP CHIP 9.1 PF + -.5PF COG
C434	2113928C04	CAP CER CHIP 4.7UF 6.3V10%0805
C435	2113743N24	CAP CHIP 8.2 PF + -.5PF COG
C436	2113743N36	CAP CHIP 27.0 PF 5% COG
C444	2113743N50	CAP CHIP 100 PF 5% COG
C445	2113743N50	CAP CHIP 100 PF 5% COG
C450	2113743N18	CAP CHIP 4.7 PF +- .25PF COG
C451	2113743N18	CAP CHIP 4.7 PF +- .25PF COG
C452	2113743N30	CAP CHIP 15.0 PF 5% COG
C453	2113743N34	CAP CHIP 22.0 PF 5% COG
C454	2113743N30	CAP CHIP 15.0 PF 5% COG

Ref. Des.	Part Number	Description
C455	2113743N10	CAP CHIP 2.2 PF +- .25PF COG
C456	2113743N10	CAP CHIP 2.2 PF +- .25PF COG
C457	2113743N67	CAP CHIP 9.0PF 16V .5PF COG
C458	2113743N67	CAP CHIP 9.0PF 16V .5PF COG
C459	2113743N50	CAP CHIP 100 PF 5% COG
C460	2113743E20	CAP CHIP .10 UF 10%
C461	2113743N13	CAP CHIP 3.0 PF +- .25PF COG
C470	2113743N28	CAP CHIP 12.0 PF 5% COG
C471	2113743N13	CAP CHIP 3.0 PF +- .25PF COG
C472	2113743N50	CAP CHIP 100 PF 5% COG
C473	2113743N50	CAP CHIP 100 PF 5% COG
C474	2113743L29	CAP CHIP 3300 PF 10% X7R
C476	2113743N28	CAP CHIP 12.0 PF 5% COG
C479	2113743N13	CAP CHIP 3.0 PF +- .25PF COG
C490	2113743N18	CAP CHIP 4.7 PF +- .25PF COG
C491	2113740F20	CAP CHIP REEL CL1 +/-30 5.1
C5	2113740F24	CAP CHIP REEL CL1 +/-30 7.5
C500	2113743N13	CAP CHIP 3.0 PF +- .25PF COG
C501	2113743N54	CAP CHIP 150 PF 5% COG
C512	2113743L29	CAP CHIP 3300 PF 10% X7R
C515	2113743L41	CAP CHIP 10000 PF 10% X7R
C516	2113743L17	CAP CHIP 1000 PF 10% X7R
C517	2113743L41	CAP CHIP 10000 PF 10% X7R
C518	2113928N01	CAP CER CHIP 0.1UF 10% 6.3
C519	2113743L41	CAP CHIP 10000 PF 10% X7R
C520	2113928N01	CAP CER CHIP 0.1UF 10% 6.3

Ref. Des.	Part Number	Description
C521	2113928N01	CAP CER CHIP 0.1UF 10% 6.3
C522	2113743L41	CAP CHIP 10000 PF 10% X7R
C523	2113743N50	CAP CHIP 100 PF 5% COG
C524	2113743N50	CAP CHIP 100 PF 5% COG
C525	2113743L41	CAP CHIP 10000 PF 10% X7R
C526	2113743L25	CAP CHIP 2200 PF 10% X7R
C528	2113928N01	CAP CER CHIP 0.1UF 10% 6.3
C529	2113928N01	CAP CER CHIP 0.1UF 10% 6.3
C530	2113743L41	CAP CHIP 10000 PF 10% X7R
C532	2113743L41	CAP CHIP 10000 PF 10% X7R
C533	2113743N50	CAP CHIP 100 PF 5% COG
C534	2113743N50	CAP CHIP 100 PF 5% COG
C535	2113743N46	QAP CHIP 68.0 PF 5% COG
C536	2113928N01	CAP CER CHIP 0.1UF 10% 6.3
C537	2113928N01	CAP CER CHIP 0.1UF 10% 6.3
C539	2113743L41	CAP CHIP 10000 PF 10% X7R
C541	2113928N01	CAP CER CHIP 0.1UF 10% 6.3
C543	2113743L41	CAP CHIP 10000 PF 10% X7R
C547	2113743N24	CAP CHIP 8.2 PF + -.5PF COG
C550	2113743E20	CAP CHIP .10 UF 10%
C551	2113743N13	CAP CHIP 3.0 PF +- .25PF COG
C552	2113743L17	CAP CHIP 1000 PF 10% X7R
C553	2113743L50	CAP CHIP 33000 PF 10%
C554	2113743N26	CAP CHIP 10.0 PF 5% COG
C555	2113743N28	CAP CHIP 12.0 PF 5% COG
C556	2113743N44	CAP CHIP 56.0 PF 5% COG
C557	2113743N44	CAP CHIP 56.0 PF 5% COG



Ref. Des.	Part Number	Description
C558	2113928N01	CAP CER CHIP 0.1UF 10% 6.3
C559	2113743L41	CAP CHIP 10000 PF 10% X7R
C560	2113743N36	CAP CHIP 27.0 PF 5% COG
C570	2113743A24	CAP CHIP .330 UF 10% 16V
C571	2113743A24	CAP CHIP .330 UF 10% 16V
C6	2113740F51	CAP CHIP REEL CL1 +/-30 100
C7	2113740F24	CAP CHIP REEL CL1 +/-30 7.5
C702	2113743N50	CAP CHIP 100 PF 5% COG
C703	2113740F51	CAP CHIP REEL CL1 +/-30 100
C704	2113740F51	CAP CHIP REEL CL1 +/-30 100
C705	2113740F63	CAP CHIP CL1 +/-30 330 5%
C706	2113743N50	CAP CHIP 100 PF 5% COG
C707	2113740F11	CAP CHIP REEL CL1 +/-30 2.2
C708	2113740F11	CAP CHIP REEL CL1 +/-30 2.2
C709	2113740F18	CAP CHIP REEL CL1 +/-30 4.3
C710	2113740F18	CAP CHIP REEL CL1 +/-30 4.3
C711	2113740F11	CAP CHIP REEL CL1 +/-30 2.2
C712	2113740F11	CAP CHIP REEL CL1 +/-30 2.2
C713	2113740F11	CAP CHIP REEL CL1 +/-30 2.2
C714	2113740F11	CAP CHIP REEL CL1 +/-30 2.2
C715	2113740F51	CAP CHIP REEL CL1 +/-30 100
C8	2113743S01	CAP CER CHIP 1.0 UF 10% 16V
C9	2113743N50	CAP CHIP 100 PF 5% COG
C925	2109720D14	CAP CER CHIP LOW DIST .1 UF

Ref. Des.	Part Number	Description
D1	4813833A20	DIODE SCHOTTKY 1A 40V PWRMITE
D101	4802197J83	DUAL SHOTTKY DIODE MBD330DWT1
D102	4802197J83	DUAL SHOTTKY DIODE MBD330DWT1
D104	4805129M06	DIODE MMBD7000
D2	4813833A20	DIODE SCHOTTKY 1A 40V PWRMITE
D201	4802233J09	DIODE TRIPLE SOT25-RH
D202	4802233J09	DIODE TRIPLE SOT25-RH
D3	4813833A20	DIODE SCHOTTKY 1A 40V PWRMITE
D301	4809877C08	DIODE VARACTOR 1SV279 SMD
D302	4809877C08	DIODE VARACTOR 1SV279 SMD
D303	4809877C08	DIODE VARACTOR 1SV279 SMD
D304	4809877C08	DIODE VARACTOR 1SV279 SMD
D305	4809877C08	DIODE VARACTOR 1SV279 SMD
D306	4809877C08	DIODE VARACTOR 1SV279 SMD
D307	4809877C08	DIODE VARACTOR 1SV279 SMD
D308	4809877C08	DIODE VARACTOR 1SV279 SMD
D309	4809877C08	DIODE VARACTOR 1SV279 SMD
D310	4809877C08	DIODE VARACTOR 1SV279 SMD
D311	4809877C08	DIODE VARACTOR 1SV279 SMD
D312	4809877C08	DIODE VARACTOR 1SV279 SMD
D313	4809877C08	DIODE VARACTOR 1SV279 SMD
D314	4809877C08	DIODE VARACTOR 1SV279 SMD
D315	4809877C08	DIODE VARACTOR 1SV279 SMD
D316	4809877C08	DIODE VARACTOR 1SV279 SMD

Ref. Des.	Part Number	Description
D320	4805218N57	DIODE DUAL
D400	4813825A19	DIODE SCHOTTKY BARRIER SERIES
D411	4809877C13	DIODE VARACTOR ISV305 SMD
D412	4809877C13	DIODE VARACTOR ISV305 SMD
D451	4809877C13	DIODE VARACTOR ISV305 SMD
D452	4809877C13	DIODE VARACTOR ISV305 SMD
D501	4809877C08	DIODE VARACTOR 1SV279 SMD
D550	4809877C13	DIODE VARACTOR ISV305 SMD
D551	4809877C13	DIODE VARACTOR ISV305 SMD
D701	4805656W24	DIODE, PIN RF
D702	4805656W24	DIODE, PIN RF
E1	2405688Z01	INDUCTOR FERRITE BEAD
E101	2405688Z01	INDUCTOR FERRITE BEAD
E105	2480640Z01	SURFACE MOUNT FERRITE BEAD
E5	2480640Z01	SURFACE MOUNT FERRITE BEAD
E501	2480640Z01	SURFACE MOUNT FERRITE BEAD
E502	2480640Z01	SURFACE MOUNT FERRITE BEAD
E503	2480640Z01	SURFACE MOUNT FERRITE BEAD
E504	2480640Z01	SURFACE MOUNT FERRITE BEAD
E505	2480640Z01	SURFACE MOUNT FERRITE BEAD
E506	2480640Z01	SURFACE MOUNT FERRITE BEAD
E507	2480640Z01	SURFACE MOUNT FERRITE BEAD
E508	2480640Z01	SURFACE MOUNT FERRITE BEAD
E509	2480640Z01	SURFACE MOUNT FERRITE BEAD

Ref. Des.	Part Number	Description
E520	2480640Z01	SURFACE MOUNT FERRITE BEAD
E6	2480640Z01	SURFACE MOUNT FERRITE BEAD
E7	2480640Z01	SURFACE MOUNT FERRITE BEAD
F901	6505757V02	FUSE SURFACE MT 2AMP
FL200	9185130D01	FLTR SW CAP 3 POLE BUTTERW
FL490	9185924B01	FILTER, 73.35 MHZ 3-POLE CRYSTAL
G1	3905643V01	CONTACT ANT GRD
G12	3905643V01	CONTACT ANT GRD
G2	3905643V01	CONTACT ANT GRD
G3	3905643V01	CONTACT ANT GRD
G6	3905643V01	CONTACT ANT GRD
G7	3905643V01	CONTACT ANT GRD
G8	3905643V01	CONTACT ANT GRD
G9	3905643V01	CONTACT ANT GRD
J1	NOTPLACED	64AM DUMMY PART NUMBER
J2	0905304Z01	CONN COAXIAL SMT
L1	2486085A04	COIL, 6.8 UH POWER INDUCTOR
L101	2460591K40	COIL AIR WOUND INDUC 59.71
L103	2480574F01	IND FERRITE CHIP 600 OHM 0603
L104	2480574F01	IND FERRITE CHIP 600 OHM 0603
L105	2413926H14	IND CHIP 15.0 NH 5%
L106	2413926H13	IND CHIP 12.0 NH 5%
L107	2413926H06	IND CHIP 3.3 NH +/- 0.3NH
L108	0662057A17	CHIP RES 47 OHMS 5%
L109	2413926H14	IND CHIP 15.0 NH 5%
L110	2460591B62	COIL AIR WOUND INDUC 11.20
L201	2462587Q20	IND CHIP 2,200 NH 20%
L202	2462587Q20	IND CHIP 2,200 NH 20%
L203	2462587Q20	IND CHIP 2,200 NH 20%
L204	2462587Q20	IND CHIP 2,200 NH 20%
L205	2462587Q47	IND CHIP 1,000 NH 10%

Ref. Des.	Part Number	Description
L207	2462587Q47	IND CHIP 1,000 NH 10%
L208	2462587Q20	IND CHIP 2,200 NH 20%
L301	2462587V59	IND CHIP 390 NH 5%
L302	2462587V59	IND CHIP 390 NH 5%
L303	2462587V59	IND CHIP 390 NH 5%
L304	2462587V59	IND CHIP 390 NH 5%
L305	2462587V59	IND CHIP 390 NH 5%
L306	2462587V59	IND CHIP 390 NH 5%
L307	2462587V59	IND CHIP 390 NH 5%
L308	2462587V59	IND CHIP 390 NH 5%
L309	2462587T38	IND CHIP 22NH 5% LOW PRO
L310	2462587T38	IND CHIP 22NH 5% LOW PRO
L311	2462587T37	IND CHIP 18NH 5% LOW PRO
L312	2462587V59	IND CHIP 390 NH 5%
L313	2462587T40	IND CHIP 33NH 5% LOW PRO
L314	2409377M14	IND CHIP WW 68 NH 5% 1608
L315	2462587V59	IND CHIP 390 NH 5%
L316	2462587V59	IND CHIP 390 NH 5%
L317	2462587V59	IND CHIP 390 NH 5%
L318	2462587V59	IND CHIP 390 NH 5%
L320	2462587T39	IND CHIP 27NH 5% LOW PRO
L321	2409377M17	IND CHIP WW 100 NH 5% 1608
L4	2460591K40	COIL AIR WOUND INDUC 59.71
L410	2462587V35	CHIP IND 120 NH 5% 0805
L411	2460591C63	COIL AIR WOUND INDUC 17.52
L412	2460591C63	COIL AIR WOUND INDUC 17.52
L430	2409154M88	IND CER MLTILYR 10.0NH 1005
L431	2409154M17	IND CER MLTILYR 22.0NH 1005
L432	2409154M50	IND CER MLTILYR 100 NH 1005

Ref. Des.	Part Number	Description
L433	2409154M92	IND CER MLTILYR 22.0NH 1005
L434	2409377M10	IND CHIP WW 33NH 5%
L438	2409154M50	IND CER MLTILYR 100 NH 1005
L451	2462587V35	CHIP IND 120 NH 5% 0805
L452	2460591C63	COIL AIR WOUND INDUC 17.52
L453	2460591C63	COIL AIR WOUND INDUC 17.52
L470	2409377M36	IND CHIP WW 220 NH 5% 1608
L473	2462587V37	CHIP IND 180 NH 5% 0805
L474	2409154M17	IND CER MLTILYR 22.0NH 1005
L475	2404574Z14	IND CHIP WW 270NH 2% 2012 SMD
L490	2462587T25	IND CHIP 620NH 5% LOW PRO
L491	2462587T25	IND CHIP 620NH 5% LOW PRO
L501	2405769X05	COIL INDUCTOR
L502	2405769X05	COIL INDUCTOR
L503	2462587Q54	IND CHIP 3,900 NH 10%
L547	2404574Z15	IND CHIP WW 330NH 2% 2012 SMD
L550	2462587T21	IND CHIP 330NH 5% LOW PRO
L701	2462587V38	CHIP IND 220 NH 5% 0805
L702	2462587V38	CHIP IND 220 NH 5% 0805
L703	2460591L49	COIL AIR WOUND INDUC 20.53
L704	2460591L49	COIL AIR WOUND INDUC 20.53
L705	2462587V38	CHIP IND 220 NH 5% 0805
L706	2413926N27	COIL 30X60 INDUCTOR 180.0 NH
L707	2413926N27	COIL 30X60 INDUCTOR 180.0 NH
P1	NOTPLACED	64AM DUMMY PART NUMBER
PCB	8485370D01	PCB RF UHF RNG 1
Q1	4813821A47	TSTR P-CH HDTMOS 20V

Ref. Des.	Part Number	Description
Q101	4813824A42	TSTR PNP 50V BIAS RES 10K 10K
Q102	4813821A47	TSTR P-CH HDTMOS 20V
Q103	4813824A42	TSTR PNP 50V BIAS RES 10K 10K
Q104	4813821A47	TSTR P-CH HDTMOS 20V
Q106	4813824A39	TSTR NPN 50V BIAS RES 22K 22K
Q107	5185633C44	RING PA
Q108	4805128M12	TSTR SOT BCW 60B (RH)
Q2	4880048M01	TSTR NPN DIG 47K/47K
Q301	4805793Y01	TRANS MINI SOT NPN LOW NOISE
Q302	4805793Y01	TRANS MINI SOT NPN LOW NOISE
Q303	4805793Y01	TRANS MINI SOT NPN LOW NOISE
Q304	4805793Y01	TRANS MINI SOT NPN LOW NOISE
Q305	4809579E16	TSTR MOSFET N-CHAN TN0200T
Q306	4809579E16	TSTR MOSFET N-CHAN TN0200T
Q307	4809579E16	TSTR MOSFET N-CHAN TN0200T
Q308	4809579E16	TSTR MOSFET N-CHAN TN0200T
Q310	4813824A42	TSTR PNP 50V BIAS RES 10K 10K
Q311	4813824A39	TSTR NPN 50V BIAS RES 22K 22K
Q430	4805585Q19	TRANSISTOR
Q501	4805128M19	TSTR SOT23 MMBTA13 RH
Q502	4805218N63	RF TRANS SOT 323 BFQ67W
Q66	4880048M01	TSTR NPN DIG 47K/47K
Q700	4813821A47	TSTR P-CH HDTMOS 20V
Q701	4880048M01	TSTR NPN DIG 47K/47K
Q99	4813821A47	TSTR P-CH HDTMOS 20V
R1	0662057N23	RES. CHIP 100K 5% 20X40
R101	0662057N23	RES. CHIP 100K 5% 20X40
R103	0662057M58	RES. CHIP 220 5% 20X40
R104	0662057M58	RES. CHIP 220 5% 20X40

Ref. Des.	Part Number	Description
R105	NOTPLACED	64AM DUMMY PART NUMBER
R106	0662057M98	RES. CHIP 10K 5% 20X40
R107	0662057M90	RES. CHIP 4700 5% 20X40
R108	0662057M90	RES. CHIP 4700 5% 20X40
R109	0662057M50	RES. CHIP 100 5% 20X40
R110	0662057M50	RES. CHIP 100 5% 20X40
R111	0662057N39	RES. CHIP 470K 5% 20X40
R112	0662057N23	RES. CHIP 100K 5% 20X40
R113	0662057N23	RES. CHIP 100K 5% 20X40
R114	0662057N23	RES. CHIP 100K 5% 20X40
R115	0662057M74	RES. CHIP 1000 5% 20X40
R117	0662057M26	RES. CHIP 10 5% 20X40
R118	0662057M50	RES. CHIP 100 5% 20X40
R119	0662057M50	RES. CHIP 100 5% 20X40
R120	0662057M50	RES. CHIP 100 5% 20X40
R121	0662057M50	RES. CHIP 100 5% 20X40
R126	0662057N06	RES. CHIP 20K 5% 20X40
R127	0662057M98	RES. CHIP 10K 5% 20X40
R128	0662057M98	RES. CHIP 10K 5% 20X40
R129	NOTPLACED	64AM DUMMY PART NUMBER
R131	0662057M98	RES. CHIP 10K 5% 20X40
R132	0662057M98	RES. CHIP 10K 5% 20X40
R201	0662057N11	RES. CHIP 33K 5% 20X40
R202	0662057M81	RES. CHIP 2000 5% 20X40
R204	0662057N17	RES. CHIP 56K 5% 20X40
R205	0662057N13	RES. CHIP 39K 5% 20X40
R207	0662057M40	RES. CHIP 39 5% 20X40
R208	0662057N11	RES. CHIP 33K 5% 20X40
R209	0662057M98	RES. CHIP 10K 5% 20X40
R210	0662057M64	RES. CHIP 390 5% 20X40
R211	0662057M74	RES. CHIP 1000 5% 20X40
R212	0662057M52	RES. CHIP 120 5% 20X40
R213	0662057M98	RES. CHIP 10K 5% 20X40
R214	0662057M74	RES. CHIP 1000 5% 20X40
R215	0662057M98	RES. CHIP 10K 5% 20X40
R216	0662057M96	RES. CHIP 8200 5% 20X40
R217	0662057M76	RES. CHIP 1200 5% 20X40

Ref. Des.	Part Number	Description
R220	NOTPLACED	64AM DUMMY PART NUMBER
R301	0662057N06	RES. CHIP 20K 5% 20X40
R302	0662057M58	RES. CHIP 220 5% 20X40
R303	0662057N07	RES. CHIP 22K 5% 20X40
R304	0662057M34	RES. CHIP 22 5% 20X40
R305	0662057N16	RES. CHIP 51K 5% 20X40
R306	0662057M32	RES. CHIP 18 5% 20X40
R307	0662057M61	RES. CHIP 300 5% 20X40
R308	0662057M61	RES. CHIP 300 5% 20X40
R309	0662057N06	RES. CHIP 20K 5% 20X40
R310	0662057M58	RES. CHIP 220 5% 20X40
R311	0662057N07	RES. CHIP 22K 5% 20X40
R312	0662057M38	RES. CHIP 33 5% 20X40
R313	0662057M34	RES. CHIP 22 5% 20X40
R314	0662057M34	RES. CHIP 22 5% 20X40
R315	0662057M42	RES. CHIP 47 5% 20X40
R316	0662057N16	RES. CHIP 51K 5% 20X40
R317	0662057N06	RES. CHIP 20K 5% 20X40
R318	0662057M58	RES. CHIP 220 5% 20X40
R319	0662057N07	RES. CHIP 22K 5% 20X40
R320	0662057M34	RES. CHIP 22 5% 20X40
R321	0662057M62	RES. CHIP 330 5% 20X40
R322	0662057N16	RES. CHIP 51K 5% 20X40
R323	0662057N06	RES. CHIP 20K 5% 20X40
R324	0662057M58	RES. CHIP 220 5% 20X40
R325	0662057N07	RES. CHIP 22K 5% 20X40
R326	0662057M34	RES. CHIP 22 5% 20X40
R327	0662057N16	RES. CHIP 51K 5% 20X40
R332	0662057M92	RES. CHIP 5600 5% 20X40
R333	0662057M58	RES. CHIP 220 5% 20X40
R400	0662057N23	RES. CHIP 100K 5% 20X40
R411	0662057M98	RES. CHIP 10K 5% 20X40
R412	0662057M98	RES. CHIP 10K 5% 20X40
R430	0662057M58	RES. CHIP 220 5% 20X40
R431	0662057M82	RES. CHIP 2200 5% 20X40
R432	0662057M82	RES. CHIP 2200 5% 20X40
R433	0662057M94	RES. CHIP 6800 5% 20X40
R434	0662057M70	RES. CHIP 680 5% 20X40

Ref. Des.	Part Number	Description
R451	0662057M98	RES. CHIP 10K 5% 20X40
R452	0662057M98	RES. CHIP 10K 5% 20X40
R470	0662057M59	RES CHIP 240 5% 20X40
R471	0662057M48	RES. CHIP 82 5% 20X40
R472	0662057M32	RES. CHIP 18 5% 20X40
R473	0662057M32	RES. CHIP 18 5% 20X40
R501	0662057N23	RES. CHIP 100K 5% 20X40
R502	0662057M56	RES. CHIP 180 5% 20X40
R503	0662057M98	RES. CHIP 10K 5% 20X40
R504	0662057M98	RES. CHIP 10K 5% 20X40
R506	0662057M98	RES. CHIP 10K 5% 20X40
R508	0662057M62	RES. CHIP 330 5% 20X40
R509	0662057M42	RES. CHIP 47 5% 20X40
R510	0662057N23	RES. CHIP 100K 5% 20X40
R511	0662057N23	RES. CHIP 100K 5% 20X40
R512	0662057M98	RES. CHIP 10K 5% 20X40
R513	0662057M98	RES. CHIP 10K 5% 20X40
R514	0662057M64	RES. CHIP 390 5% 20X40
R551	0662057M81	RES. CHIP 2000 5% 20X40
R552	0662057M95	RES. CHIP 7500 5% 20X40
R6	0662057M98	RES. CHIP 10K 5% 20X40
R7	0662057M98	RES. CHIP 10K 5% 20X40
R702	0662057A37	CHIP RES 330 OHMS 5%
R703	0662057M50	RES. CHIP 100 5% 20X40
R704	0662057N23	RES. CHIP 100K 5% 20X40
R706	0662057N23	RES. CHIP 100K 5% 20X40
R719	0662057M78	RES. CHIP 1500 5% 20X40
R720	0662057N23	RES. CHIP 100K 5% 20X40
SH201	2685787B01	SHLD FRAC-N
SH202	2685787B01	SHLD FRAC-N
SH301	2685297D01	SHLD VCO
SH302	2685298D01	SHLD VCO BUFFER
SH401	2685627A02	SHLD DUAL INDUCTOR
SH402	2685627A02	SHLD DUAL INDUCTOR
SH403	2685882A01	SHLD VCO TANK
SH501	2685298D01	SHLD VCO BUFFER
SH700	2685762D02	SHIELD HARMONIC FILTER

Ref. Des.	Part Number	Description
T471	2580541Z02	BALUN TRANSFORMER (NEW)
T472	2580541Z02	BALUN TRANSFORMER (NEW)
T473	2505515V07	XFMR JEDI MIXER 25:1
TH1	NOTPLACED	64AM DUMMY PART NUMBER
U1	5185353D13	IC MINI SO-8 HI PRECISION REG 5V
U101	5185633C23	MODULE DIRECT COUPLER
U102	5185130C65	IC VHF/UHF/800 MHZ LD MOS DRIVER
U103	5185963A15	IC TEMPERATURE SENSOR 1M50C
U104	5185765B26	IC PWR CTRL IN MOS20
U105	5185368C19	IC QUAD 10 BIT A/D CONV
U106	5185963A60	IC OP AMP
U2	5185353D14	IC SOT23-5 HI PRECISION REG 3V
U201	5186358E01	IC ANALOG OP-AMP CLC450
U202	5185963A27	IC TESTED AT25016 48 PIN GFP
U203	5185368C83	IC 12 BIT DAC
U3	5185353D14	IC SOT23-5 HI PRECISION REG 3V
U300	5105750U54	IC PKG DIE VCO BUFFER
U4	5105462G78	IC EEPROM 16K SPEI CMOS
U401	5185130C83	IC 15DB DIGITAL ATTEUATOR SOT25 PKG
U404	5185143E12	IC INVERTER DUAL SC70
U470	5185130C91	IC MIXER RF SOIC 10
U500	5185963A85	IC-ABACUS III-LP
VR1	4813830A33	DIODE 20V 5% 225MW MMBZ5250B_
VR2	4813830A15	DIODE 5.6V 5% 225MW MMBZ5232B_
VR3	4805656W45	DIODE TRANSIENT VOLTAGE SUPPRESSOR
W02	NOTPLACED	64AM DUMMY PART NUMBER

Ref. Des.	Part Number	Description
W021	NOTPLACED	64AM DUMMY PART NUMBER
W1	NOTPLACED	64AM DUMMY PART NUMBER
W10	NOTPLACED	64AM DUMMY PART NUMBER
W11	NOTPLACED	64AM DUMMY PART NUMBER
W12	NOTPLACED	64AM DUMMY PART NUMBER
W13	NOTPLACED	64AM DUMMY PART NUMBER
W14	NOTPLACED	64AM DUMMY PART NUMBER
W15	NOTPLACED	64AM DUMMY PART NUMBER
W16	NOTPLACED	64AM DUMMY PART NUMBER
W17	NOTPLACED	64AM DUMMY PART NUMBER
W18	NOTPLACED	64AM DUMMY PART NUMBER
W19	NOTPLACED	64AM DUMMY PART NUMBER
W2	NOTPLACED	64AM DUMMY PART NUMBER
W20	NOTPLACED	64AM DUMMY PART NUMBER
W21	NOTPLACED	64AM DUMMY PART NUMBER
W22	NOTPLACED	64AM DUMMY PART NUMBER
W23	NOTPLACED	64AM DUMMY PART NUMBER
W3	NOTPLACED	64AM DUMMY PART NUMBER
W4	NOTPLACED	64AM DUMMY PART NUMBER
W5	NOTPLACED	64AM DUMMY PART NUMBER
W6	NOTPLACED	64AM DUMMY PART NUMBER
W7	NOTPLACED	64AM DUMMY PART NUMBER
W8	NOTPLACED	64AM DUMMY PART NUMBER

---

Ref. Des.	Part Number	Description
W9	NOTPLACED	64AM DUMMY PART NUMBER
Y200	4802245J68	"OSC, REF 16.8 MHZ 1.5 PPM"



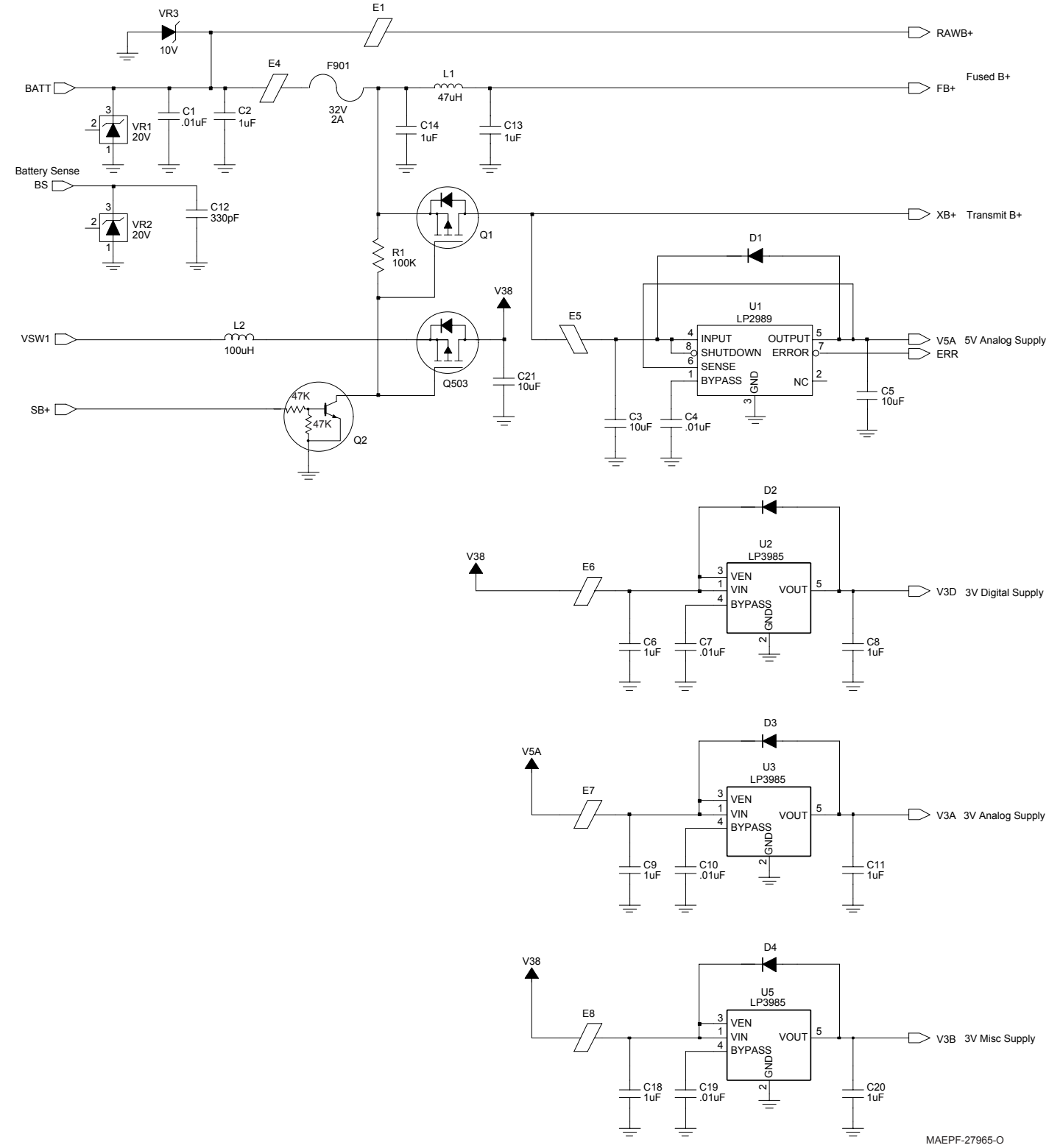
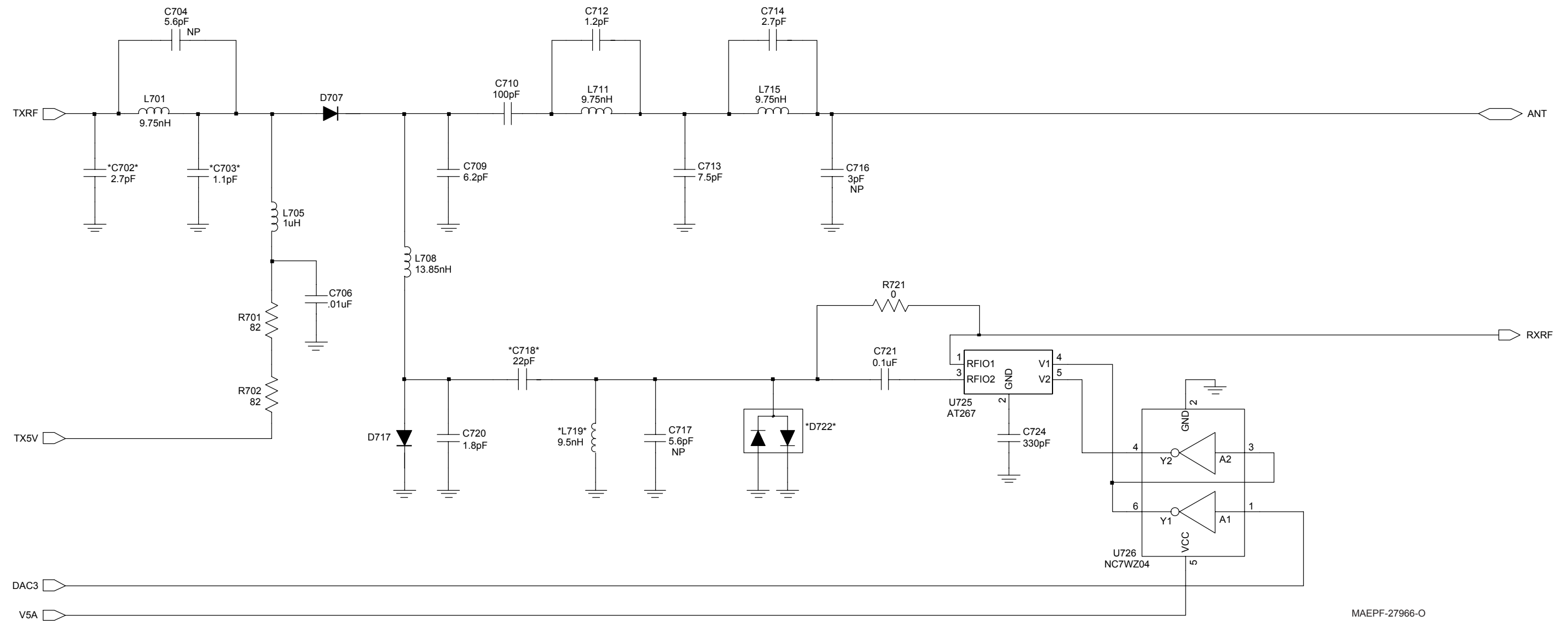

Figure 8-50. NLE 4273A UHF Range 2 D/C Power Circuit Schematic



MAEPF-27966-O

Figure 8-51. NLE 4273A UHF Range 2 Antenna Switch and Harmonic Filter Circuit Schematic

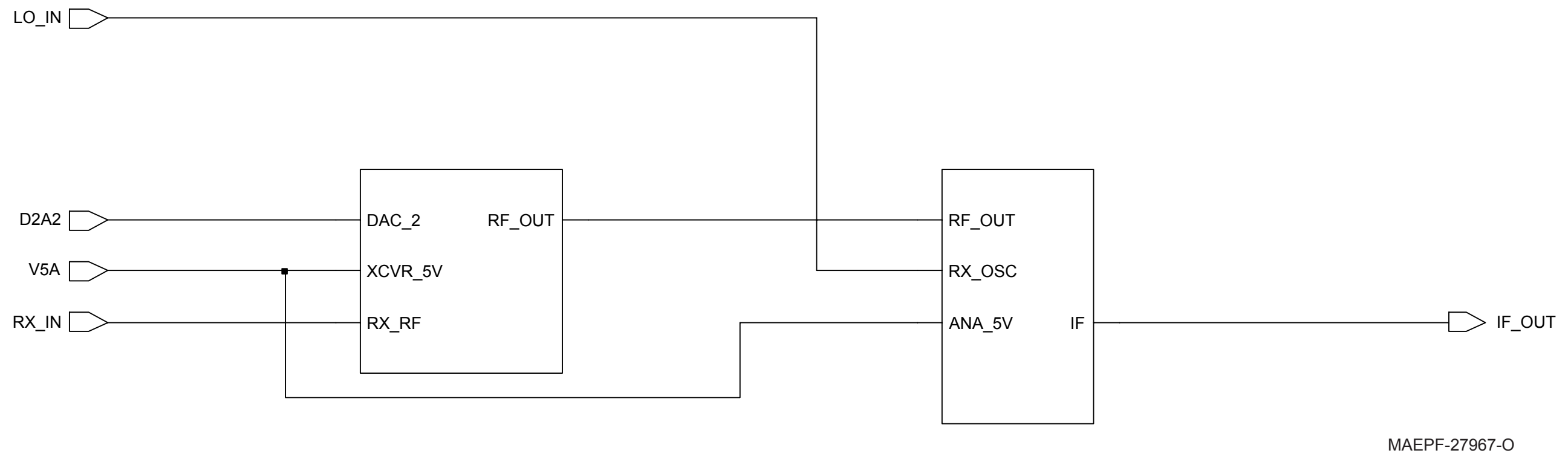
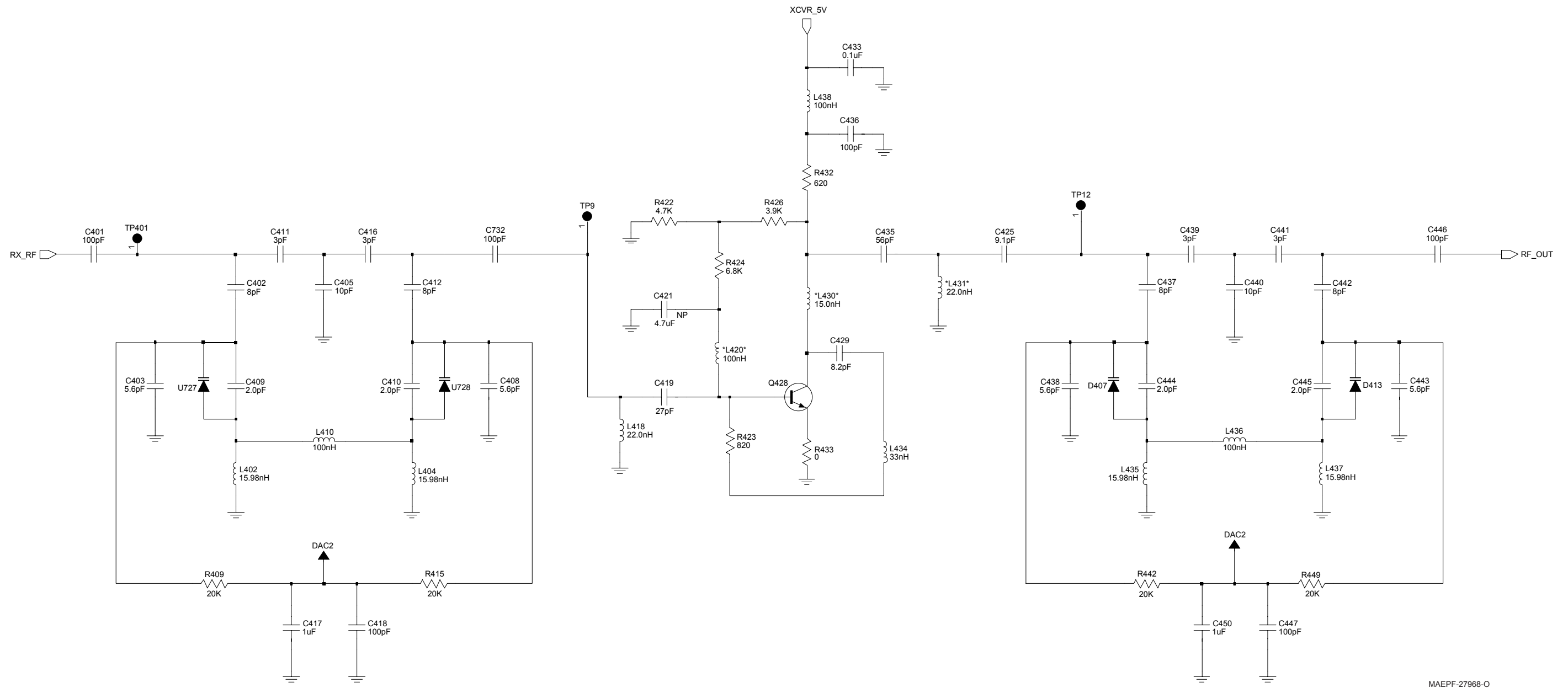

Figure 8-52. NLE 4273A UHF Range 2 Receiver Front End Circuit Schematic







MAEPF-27968-O

Figure 8-54. NLE 4273A UHF Range 2 Receiver Amplifier and Filter Circuit Schematic

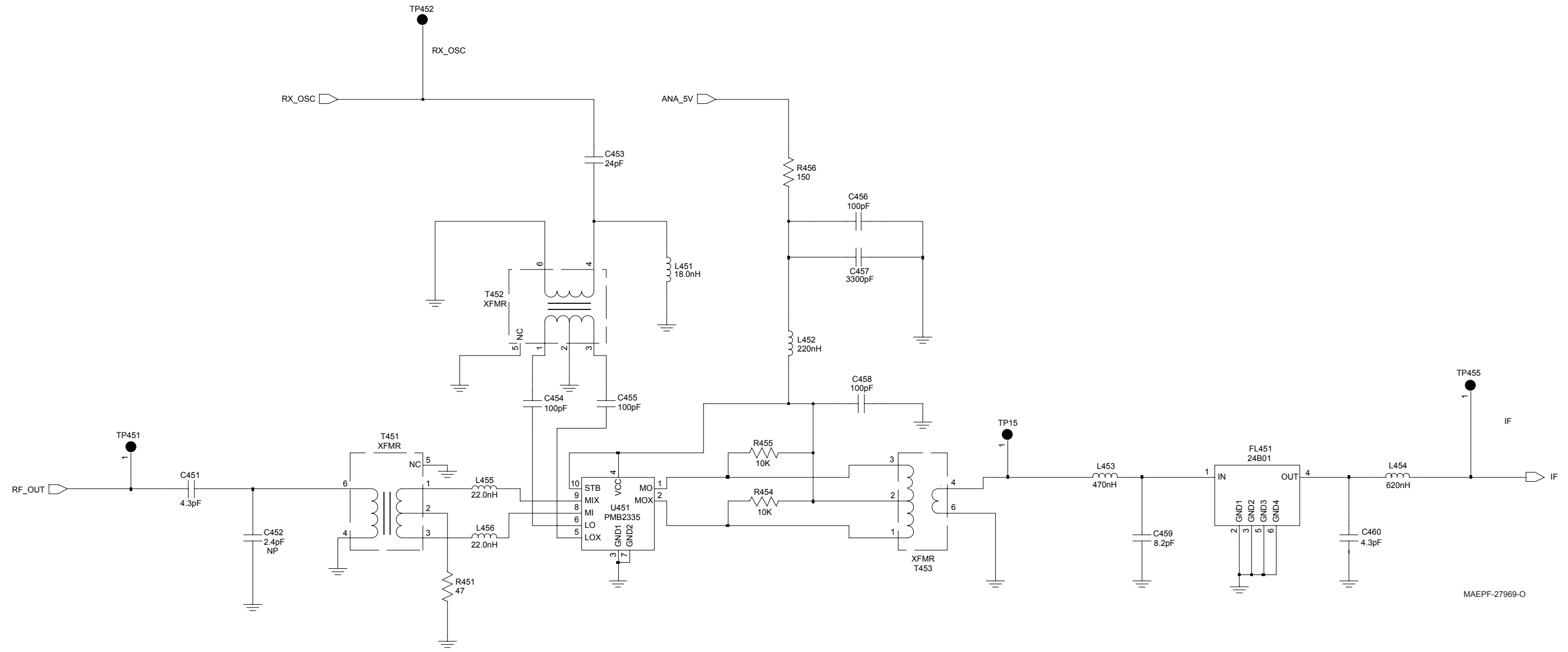

MAEPF-27969-O

Figure 8-55. NLE 4273A UHF Range 2 Mixer and IF Filter Circuit Schematic



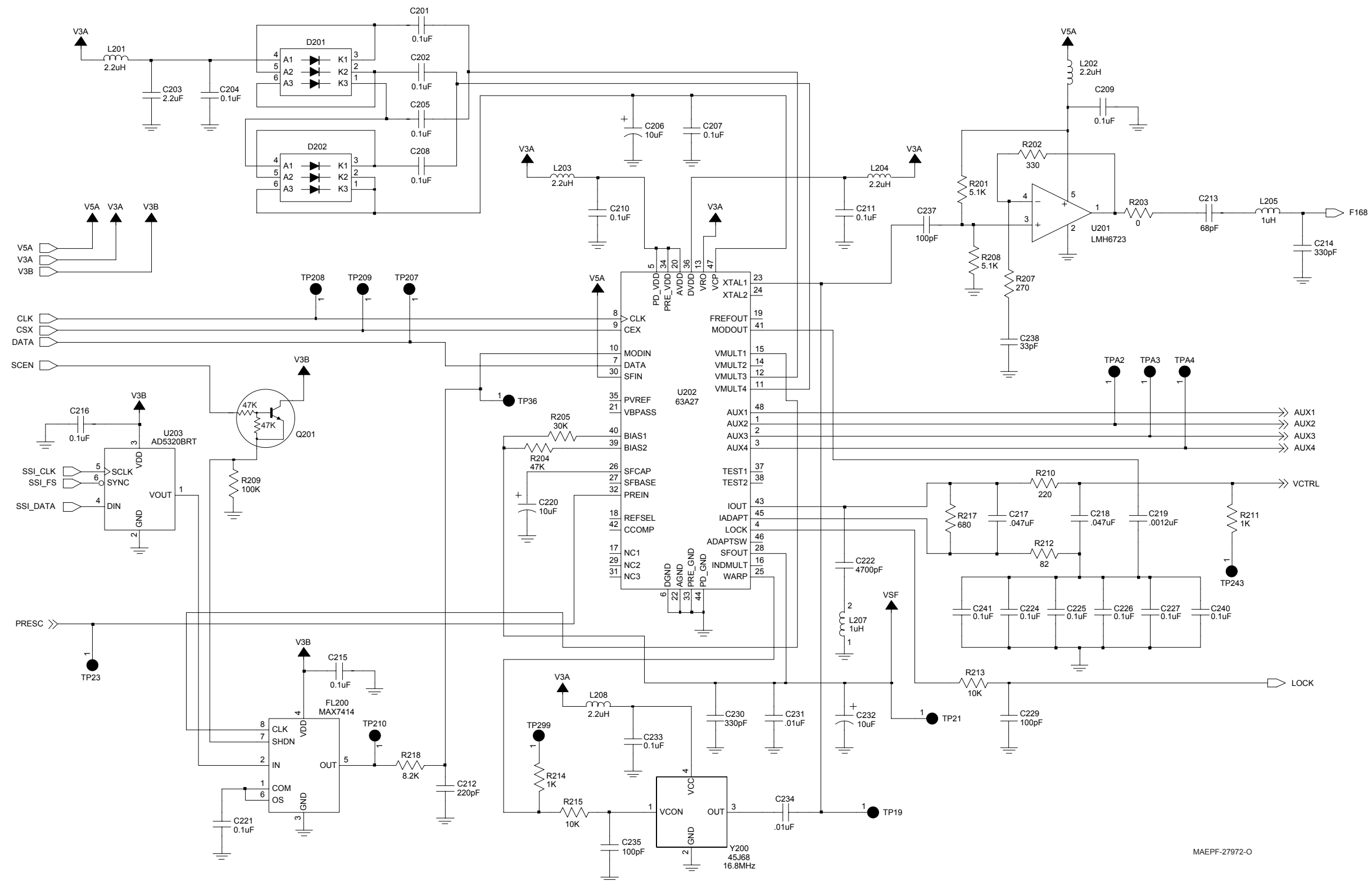
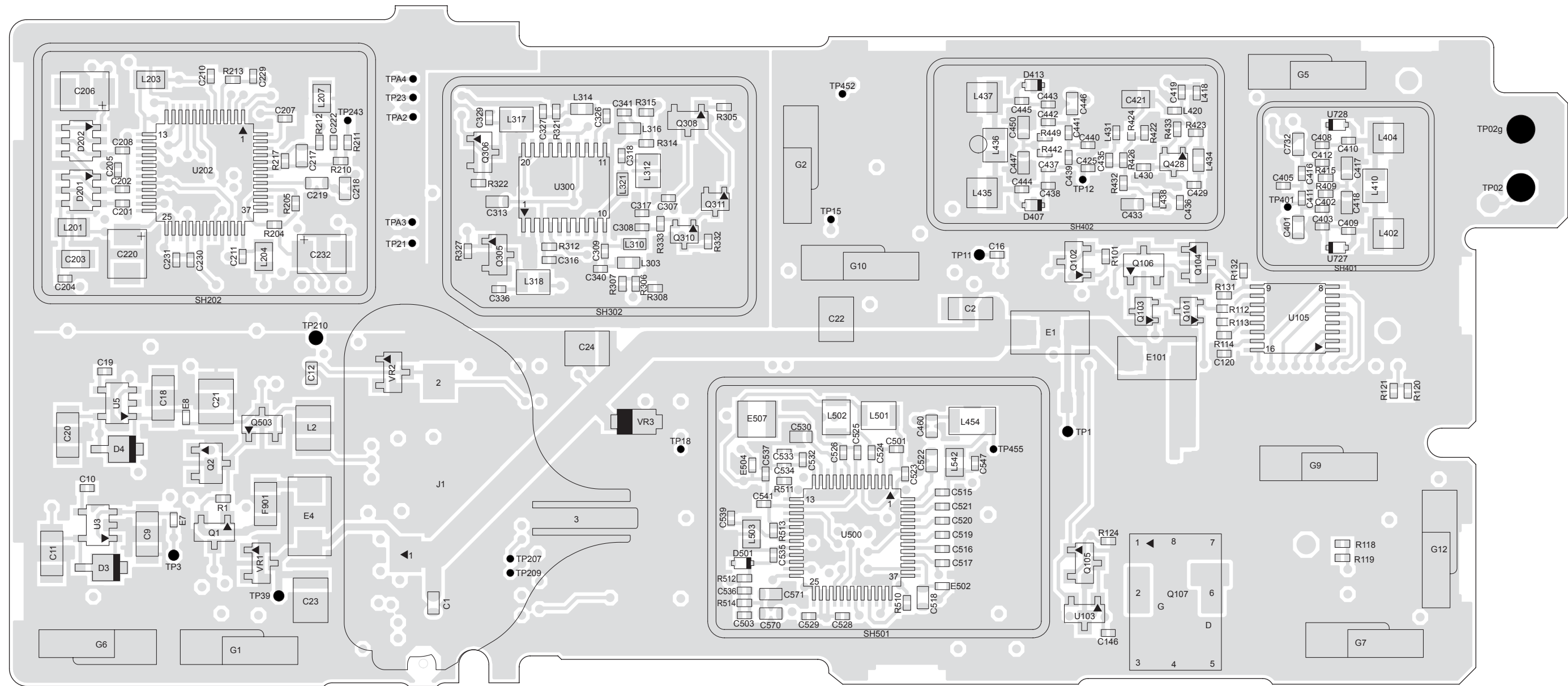

Figure 8-57. NLE 4273A UHF Range 2 Frequency Generation Unit (Synthesizer) Circuit Schematic







MAEPF-27975-O

Figure 8-60. NLE 4273A UHF Range 2 Transceiver (RF) Board Layout (Side 2) Schematic



NLE 4273A UHF Range 2 Transceiver (RF)  
Board Parts List

Ref. Des.	Part Number	Description
C1	2113741F49	CAP CHIP CL2 X7R REEL 10000
C10	2113743L41	CAP CHIP 10000 PF 10% X7R
C101	2113743E20	CAP CHIP .10 UF 10%
C102	2113741F49	CAP CHIP CL2 X7R REEL 10000
C103	2113740F51	CAP CHIP REEL CL1 +/-30 100
C104	2113741F49	CAP CHIP CL2 X7R REEL 10000
C106	2113740F51	CAP CHIP REEL CL1 +/-30 100
C108	2113740F51	CAP CHIP REEL CL1 +/-30 100
C109	2113740F41	CAP CHIP REEL CL1 +/-30 39
C11	2113743S01	CAP CER CHIP 1.0 UF 10% 16V
C110	2113740F18	CAP CHIP REEL CL1 +/-30 4.3
C111	2113740F30	CAP CHIP REEL CL1 +/-30 13
C113	2113740F51	CAP CHIP REEL CL1 +/-30 100
C114	2113740F51	CAP CHIP REEL CL1 +/-30 100
C115	2113740F51	CAP CHIP REEL CL1 +/-30 100
C117	2113740F51	CAP CHIP REEL CL1 +/-30 100
C118	2113740F51	CAP CHIP REEL CL1 +/-30 100
C119	2113740F51	CAP CHIP REEL CL1 +/-30 100
C12	2113740F63	CAP CHIP CL1 +/-30 330 5%
C120	2113743L41	CAP CHIP 10000 PF 10% X7R
C121	2113740F51	CAP CHIP REEL CL1 +/-30 100

Ref. Des.	Part Number	Description
C122	2113743L21	CAP CHIP 1500 PF 10% X7R
C123	2113743L09	CAP CHIP 470 PF 10% X7R
C124	2113946A01	CAP CER CHP 0.015UF 16V 10%
C125	2113743L41	CAP CHIP 10000 PF 10% X7R
C126	2113743L41	CAP CHIP 10000 PF 10% X7R
C13	2113743S01	CAP CER CHIP 1.0 UF 10% 16V
C130	2113743E20	CAP CHIP .10 UF 10%
C131	2311049A37	CAP TANT CHIP 1 20 20
C133	2113743L41	CAP CHIP 10000 PF 10% X7R
C134	2113740F51	CAP CHIP REEL CL1 +/-30 100
C135	2113740F51	CAP CHIP REEL CL1 +/-30 100
C136	2311049A37	CAP TANT CHIP 1 20 20
C137	2113742J10	CAP 39.0 PF 5%
C139	2113742J04	CAP 20.0 PF 5%
C14	2113743S01	CAP CER CHIP 1.0 UF 10% 16V
C140	2113740F23	CAP CHIP REEL CL1 +/-30 6.8
C142	2113740F51	CAP CHIP REEL CL1 +/-30 100
C143	2113740F51	CAP CHIP REEL CL1 +/-30 100
C144	2113740F51	CAP CHIP REEL CL1 +/-30 100
C146	2113743L41	CAP CHIP 10000 PF 10% X7R
C147	2113740F33	CAP CHIP REEL CL1 +/-30 18
C148	2113740F33	CAP CHIP REEL CL1 +/-30 18
C149	2113742H20	CAP 2.0 PF +/- .10 PF
C15	2113743E20	CAP CHIP .10 UF 10%
C151	2113742H40	CAP 12.0 PF 5%
C16	2113743N13	CAP CHIP 3.0 PF +/- .25PF COG

Ref. Des.	Part Number	Description
C18	2113743S01	CAP CER CHIP 1.0 UF 10% 16V
C19	2113743L41	CAP CHIP 10000 PF 10% X7R
C2	2113743S01	CAP CER CHIP 1.0 UF 10% 16V
C20	2113743S01	CAP CER CHIP 1.0 UF 10% 16V
C201	2113743M24	CAP CHIP 100000 PF +80-20% Y5V
C202	2113743M24	CAP CHIP 100000 PF +80-20% Y5V
C203	2113743F18	CAP CHIP 2.2 UF 16V +80-20%
C204	2113743M24	CAP CHIP 100000 PF +80-20% Y5V
C205	2113743M24	CAP CHIP 100000 PF +80-20% Y5V
C206	2311049A57	CAP TANT CHIP A/P 10UF 10% 16V
C207	2113743M24	CAP CHIP 100000 PF +80-20% Y5V
C208	2113743M24	CAP CHIP 100000 PF +80-20% Y5V
C209	2113743M24	CAP CHIP 100000 PF +80-20% Y5V
C21	2113743T19	CAP 10UF 16V CER 3225 X5R
C210	2113743M24	CAP CHIP 100000 PF +80-20% Y5V
C211	2113743M24	CAP CHIP 100000 PF +80-20% Y5V
C212	2113743L01	CAP CHIP 220 PF 10% X7R
C213	2113743N46	QAP CHIP 68.0 PF 5% COG
C214	2113743L05	CAP CHIP 330 PF 10% X7R
C215	2113743M24	CAP CHIP 100000 PF +80-20% Y5V
C216	2113743M24	CAP CHIP 100000 PF +80-20% Y5V
C217	2113743E12	CAP CHIP .047 UF 10% X7R
C218	2113743E12	CAP CHIP .047 UF 10% X7R

Ref. Des.	Part Number	Description
C219	2185419D08	CAP CER SUPER L/D 0.0012UF
C22	2113743T19	CAP 10UF 16V CER 3225 X5R
C220	2311049A57	CAP TANT CHIP A/P 10UF 10% 16V
C221	2113743M24	CAP CHIP 100000 PF +80-20% Y5V
C222	2113743L33	CAP CHIP 4700 PF 10% X7R
C224	2185419D06	CAP CER SUPER L/D 0.1UF
C225	2185419D06	CAP CER SUPER L/D 0.1UF
C226	2185419D06	CAP CER SUPER L/D 0.1UF
C227	2185419D06	CAP CER SUPER L/D 0.1UF
C229	2113743N50	CAP CHIP 100 PF 5% COG
C23	2113743T19	CAP 10UF 16V CER 3225 X5R
C230	2113743L05	CAP CHIP 330 PF 10% X7R
C231	2113743L41	CAP CHIP 10000 PF 10% X7R
C232	2311049A57	CAP TANT CHIP A/P 10UF 10% 16V
C233	2113743M24	CAP CHIP 100000 PF +80-20% Y5V
C234	2113743L41	CAP CHIP 10000 PF 10% X7R
C235	2113743N50	CAP CHIP 100 PF 5% COG
C237	2113743N50	CAP CHIP 100 PF 5% COG
C238	2113743N38	CAP CHIP 33.0 PF 5% COG
C24	2113743T19	CAP 10UF 16V CER 3225 X5R
C240	2185419D06	CAP CER SUPER L/D 0.1UF
C241	2185419D06	CAP CER SUPER L/D 0.1UF
C28	2113743L17	CAP CHIP 1000 PF 10% X7R
C3	2113743T19	CAP 10UF 16V CER 3225 X5R
C301	2113740L08	CAP CER CHIP 3.9 PF +/- 0.1PF

Ref. Des.	Part Number	Description
C302	2113740L08	CAP CER CHIP 3.9 PF +- 0.1PF
C303	2113740F07	CAP CHIP REEL CL1 +/-30 1.5
C304	2113740L02	CAP CER CHIP 2.2 PF +- 0.1PF
C306	2113740L08	CAP CER CHIP 3.9 PF +- 0.1PF
C307	2113743N52	CAP CHIP 120 PF 5% COG
C308	2113743N34	CAP CHIP 22.0 PF 5% COG
C309	2113743N44	CAP CHIP 56.0 PF 5% COG
C313	2113743E20	CAP CHIP .10 UF 10%
C316	2113743N52	CAP CHIP 120 PF 5% COG
C317	2113743N52	CAP CHIP 120 PF 5% COG
C318	2113743N52	CAP CHIP 120 PF 5% COG
C321	2113740L03	CAP CER CHIP 2.4 PF +- 0.1PF
C322	2113740L03	CAP CER CHIP 2.4 PF +- 0.1PF
C323	2104801Z12	CAP CER NPO 1.8PF 16V 1005 SMD
C324	2113740L06	CAP CER CHIP 3.3 PF +- 0.1PF
C326	2113743N52	CAP CHIP 120 PF 5% COG
C327	2113743N52	CAP CHIP 120 PF 5% COG
C328	2113743N24	CAP CHIP 8.2 PF +-.5PF COG
C329	2113743N52	CAP CHIP 120 PF 5% COG
C330	2113740L01	CAP CER CHIP 2.0 PF +- 0.1PF
C331	2113740L02	CAP CER CHIP 2.2 PF +- 0.1PF
C332	2104801Z10	CAP CER NPO 1.5PF 16V 1005 SMD
C333	2113740L06	CAP CER CHIP 3.3 PF +- 0.1PF
C335	2113743N24	CAP CHIP 8.2 PF +-.5PF COG
C336	2113743N52	CAP CHIP 120 PF 5% COG
C340	2113743N20	CAP CHIP 5.6 PF +-.5PF COG
C341	2113743N30	CAP CHIP 15.0 PF 5% COG

Ref. Des.	Part Number	Description
C4	2113743L41	CAP CHIP 10000 PF 10% X7R
C401	2113740F51	CAP CHIP REEL CL1 +/-30 100
C402	2113743N65	CAP CHIP 8.0PF 16V .5PF COG
C403	2113743N20	CAP CHIP 5.6 PF +-.5PF COG
C405	2113743N26	CAP CHIP 10.0 PF 5% COG
C408	2113743N20	CAP CHIP 5.6 PF +-.5PF COG
C409	2113944A08	CAP CER CHP 2.0PF 50V +/- 0.25PF
C410	2113944A08	CAP CER CHP 2.0PF 50V +/- 0.25PF
C411	2113743N13	CAP CHIP 3.0 PF +-.25PF COG
C412	2113743N65	CAP CHIP 8.0PF 16V .5PF COG
C416	2113743N13	CAP CHIP 3.0 PF +-.25PF COG
C417	2113928H09	CAP CER CHIP Q.0 UF 10V
C418	2113740F51	CAP CHIP REEL CL1 +/-30 100
C419	2113743N36	CAP CHIP 27.0 PF 5% COG
C421	NOTPLACED	64AM DUMMY PART NUMBER
C425	2113743N25	CAP CHIP 9.1 PF +-.5PF COG
C429	2113743N24	CAP CHIP 8.2 PF +-.5PF COG
C433	2113743E20	CAP CHIP .10 UF 10%
C435	2113743N44	CAP CHIP 56.0 PF 5% COG
C436	2113743N50	CAP CHIP 100 PF 5% COG
C437	2113743N65	CAP CHIP 8.0PF 16V .5PF COG
C438	2113743N20	CAP CHIP 5.6 PF +-.5PF COG
C439	2113743N13	CAP CHIP 3.0 PF +-.25PF COG
C440	2113743N26	CAP CHIP 10.0 PF 5% COG
C441	2113743N13	CAP CHIP 3.0 PF +-.25PF COG
C442	2113743N65	CAP CHIP 8.0PF 16V .5PF COG

Ref. Des.	Part Number	Description
C443	2113743N20	CAP CHIP 5.6 PF +-.5PF COG
C444	2113944A08	CAP CER CHP 2.0PF 50V +/- 0.25PF
C445	2113944A08	CAP CER CHP 2.0PF 50V +/- 0.25PF
C446	2113740F51	CAP CHIP REEL CL1 +/-30 100
C447	2113740F51	CAP CHIP REEL CL1 +/-30 100
C450	2113928H09	CAP CER CHIP Q.0 UF 10V
C451	2113743N17	CAP CHIP 4.3 PF +-.25PF COG
C452	NOTPLACED	64AM DUMMY PART NUMBER
C453	2113743N35	CAP CHIP 24.0 PF 5% COG
C454	2113743N50	CAP CHIP 100 PF 5% COG
C455	2113743N50	CAP CHIP 100 PF 5% COG
C456	2113743N50	CAP CHIP 100 PF 5% COG
C457	2113743L29	CAP CHIP 3300 PF 10% X7R
C458	2113743N50	CAP CHIP 100 PF 5% COG
C459	2113740F25	CAP CHIP REEL CL1 +/-30 8.2
C460	2113740F18	CAP CHIP REEL CL1 +/-30 4.3
C5	2113743T19	CAP 10UF 16V CER 3225 X5R
C501	2113743N54	CAP CHIP 150 PF 5% COG
C502	2113743M24	CAP CHIP 100000 PF +80-20% Y5V
C503	2113928N01	CAP CER CHIP 0.1UF 10% 6.3
C515	2113743L41	CAP CHIP 10000 PF 10% X7R
C516	2113743M24	CAP CHIP 100000 PF +80-20% Y5V
C517	2113743M24	CAP CHIP 100000 PF +80-20% Y5V
C518	2113743E12	CAP CHIP .047 UF 10% X7R
C519	2113743M24	CAP CHIP 100000 PF +80-20% Y5V

Ref. Des.	Part Number	Description
C520	2113743M24	CAP CHIP 100000 PF +80-20% Y5V
C521	2113743M24	CAP CHIP 100000 PF +80-20% Y5V
C522	2113743E12	CAP CHIP .047 UF 10% X7R
C523	2113743N50	CAP CHIP 100 PF 5% COG
C524	2113743N50	CAP CHIP 100 PF 5% COG
C525	2113743M24	CAP CHIP 100000 PF +80-20% Y5V
C526	2113743L25	CAP CHIP 2200 PF 10% X7R
C528	2113743M24	CAP CHIP 100000 PF +80-20% Y5V
C529	2113743M24	CAP CHIP 100000 PF +80-20% Y5V
C530	2113743E12	CAP CHIP .047 UF 10% X7R
C532	2113743M24	CAP CHIP 100000 PF +80-20% Y5V
C533	2113743N50	CAP CHIP 100 PF 5% COG
C534	2113743N50	CAP CHIP 100 PF 5% COG
C535	2113743N46	QAP CHIP 68.0 PF 5% COG
C536	2113928N01	CAP CER CHIP 0.1UF 10% 6.3
C537	2113743M24	CAP CHIP 100000 PF +80-20% Y5V
C539	2113743L41	CAP CHIP 10000 PF 10% X7R
C541	2113743M24	CAP CHIP 100000 PF +80-20% Y5V
C543	2113743M24	CAP CHIP 100000 PF +80-20% Y5V
C544	2113743L01	CAP CHIP 220 PF 10% X7R
C547	2113743N24	CAP CHIP 8.2 PF +-.5PF COG
C550	2311049A62	CAP TAN CHIP A/P 4.7 10 10
C552	2113743L41	CAP CHIP 10000 PF 10% X7R
C553	2311049A62	CAP TAN CHIP A/P 4.7 10 10
C554	2113743N26	CAP CHIP 10.0 PF 5% COG
C555	2113743N30	CAP CHIP 15.0 PF 5% COG

Ref. Des.	Part Number	Description
C556	2113743N44	CAP CHIP 56.0 PF 5% COG
C557	2113743N44	CAP CHIP 56.0 PF 5% COG
C558	2113928N01	CAP CER CHIP 0.1UF 10% 6.3
C559	2113946D01	CAP CER CHP 0.47UF 6.3V 10%
C560	2113743N36	CAP CHIP 27.0 PF 5% COG
C570	2113946D01	CAP CER CHP 0.47UF 6.3V 10%
C571	2113946D01	CAP CER CHP 0.47UF 6.3V 10%
C6	2113743S01	CAP CER CHIP 1.0 UF 10% 16V
C7	2113743L41	CAP CHIP 10000 PF 10% X7R
C702	2113740L08	CAP CER CHIP 3.9 PF +/- 0.1PF
C703	2113740F05	CAP CHIP REEL CL1 +/-30 1.2
C704	NOTPLACED	64AM DUMMY PART NUMBER
C706	2113743L41	CAP CHIP 10000 PF 10% X7R
C709	2113740F22	CAP CHIP REEL CL1 +/-30 6.2
C710	2113740F51	CAP CHIP REEL CL1 +/-30 100
C712	2113740F05	CAP CHIP REEL CL1 +/-30 1.2
C713	2113740F24	CAP CHIP REEL CL1 +/-30 7.5
C714	2113740L04	CAP CER CHIP 2.7 PF +/- 0.1PF
C716	NOTPLACED	64AM DUMMY PART NUMBER
C717	NOTPLACED	64AM DUMMY PART NUMBER
C718	2113743N24	CAP CHIP 8.2 PF + .5PF COG
C720	2109445U09	CAP CER COG 1.8 .1% 0402 SMD
C721	2113743E20	CAP CHIP .10 UF 10%
C724	2113740F63	CAP CHIP CL1 +/-30 330 5%

Ref. Des.	Part Number	Description
C731	2113928E01	CAP CER CHIP 1.0 UF 10 % 10V
C732	2113740F51	CAP CHIP REEL CL1 +/-30 100
C8	2113743S01	CAP CER CHIP 1.0 UF 10% 16V
C9	2113743S01	CAP CER CHIP 1.0 UF 10% 16V
D1	4813833A20	DIODE SCHOTTKY 1A 40V PWRMITE
D101	4802197J83	DUAL SHOTTKY DIODE MBD330DWT1
D102	4802197J83	DUAL SHOTTKY DIODE MBD330DWT1
D103	4805129M06	DIODE MMBD7000
D2	4813833A20	DIODE SCHOTTKY 1A 40V PWRMITE
D201	4802233J09	DIODE TRIPLE SOT25-RH
D202	4802233J09	DIODE TRIPLE SOT25-RH
D3	4813833A20	DIODE SCHOTTKY 1A 40V PWRMITE
D301	4809877C08	DIODE VARACTOR 1SV279 SMD
D302	4809877C08	DIODE VARACTOR 1SV279 SMD
D303	4809877C08	DIODE VARACTOR 1SV279 SMD
D304	4809877C08	DIODE VARACTOR 1SV279 SMD
D309	4809877C08	DIODE VARACTOR 1SV279 SMD
D310	4809877C08	DIODE VARACTOR 1SV279 SMD
D311	4809877C08	DIODE VARACTOR 1SV279 SMD
D312	4809877C08	DIODE VARACTOR 1SV279 SMD
D313	4809877C08	DIODE VARACTOR 1SV279 SMD
D314	4809877C08	DIODE VARACTOR 1SV279 SMD
D315	4809877C08	DIODE VARACTOR 1SV279 SMD
D316	4809877C08	DIODE VARACTOR 1SV279 SMD

Ref. Des.	Part Number	Description
D4	4813833A20	DIODE SCHOTTKY 1A 40V PWRMITE
D407	4809877C13	DIODE VARACTOR ISV305 SMD
D413	4809877C13	DIODE VARACTOR ISV305 SMD
D501	4809877C08	DIODE VARACTOR 1SV279 SMD
D550	NOTPLACED	64AM DUMMY PART NUMBER
D551	4809877C13	DIODE VARACTOR ISV305 SMD
D707	4805656W24	DIODE, PIN RF
D717	4805656W24	DIODE, PIN RF
D722	4813825A19	DIODE SCHOTTKY BARRIER SERIES
E1	2405688Z01	INDUCTOR FERRITE BEAD
E101	2405688Z01	INDUCTOR FERRITE BEAD
E102	2480574F01	IND FERRITE CHIP 600 OHM 0603
E105	2480574F01	IND FERRITE CHIP 600 OHM 0603
E4	2405688Z01	INDUCTOR FERRITE BEAD
E5	2480640Z01	SURFACE MOUNT FERRITE BEAD
E502	2480640Z01	SURFACE MOUNT FERRITE BEAD
E504	2480640Z01	SURFACE MOUNT FERRITE BEAD
E507	2462587N76	CHIP IND 4700 NH 5%
E6	2480640Z01	SURFACE MOUNT FERRITE BEAD
E7	2480640Z01	SURFACE MOUNT FERRITE BEAD
E8	2480640Z01	SURFACE MOUNT FERRITE BEAD
F901	6505757V02	FUSE SURFACE MT 2AMP
FL200	9185130D01	FLTR SW CAP 3 POLE BUTTERW
FL451	9185924B01	FILTER, 73.35 MHZ 3-POLE CRYSTAL
G1	3905643V01	CONTACT ANT GRD

Ref. Des.	Part Number	Description
G10	3905643V01	CONTACT ANT GRD
G12	3905643V01	CONTACT ANT GRD
G2	3905643V01	CONTACT ANT GRD
G5	3905643V01	CONTACT ANT GRD
G6	3905643V01	CONTACT ANT GRD
G7	3905643V01	CONTACT ANT GRD
G9	3905643V01	CONTACT ANT GRD
J1	NOTPLACED	64AM DUMMY PART NUMBER
J2	0905304Z01	CONN COAXIAL SMT
L1	2486085A06	COIL 47UH SMT POWER INDUCTOR
L101	2460591E24	COIL AIR WOUND INDUC 23.75
L103	2462587N56	CHIP IND 180 NH 5%
L105	2413926F04	IND 2.2 NH +/-0.3 NH
L107	2409377M26	IDCTR,CHIP,8.7NH,5%,700 MA,.109OHM,S
L108	2413926G08	IND 12.0 NH 5%
L109	2413926G09	IND 15.0 NH 5%
L113	2409348J01	IND AIR CORE 1.65NH 10% 2214
L114	2460591A50	COIL AIR WOUND INDUC 9.75
L120	2409377M03	IDCTR,CHIP,6.8NH,5%,700 MA,.11OHM,SM
L121	2409377M03	IDCTR,CHIP,6.8NH,5%,700 MA,.11OHM,SM
L2	2462587L50	FERRITE INDUCTOR 100UH
L201	2462587Q20	IND CHIP 2,200 NH 20%
L202	2462587Q20	IND CHIP 2,200 NH 20%
L203	2462587Q20	IND CHIP 2,200 NH 20%
L204	2462587Q20	IND CHIP 2,200 NH 20%
L205	2462587Q47	IND CHIP 1,000 NH 10%
L207	2462587Q47	IND CHIP 1,000 NH 10%
L208	2462587Q20	IND CHIP 2,200 NH 20%
L301	2462587V59	IND CHIP 390 NH 5%
L302	2462587V59	IND CHIP 390 NH 5%
L303	2409377M07	IDCTR,CHIP,18NH,5%,700 MA,.17OHM,SM,

Ref. Des.	Part Number	Description
L305	2462587V59	IND CHIP 390 NH 5%
L306	2462587V59	IND CHIP 390 NH 5%
L307	2462587V59	IND CHIP 390 NH 5%
L308	2462587V59	IND CHIP 390 NH 5%
L309	2460591C62	INDUCTOR 14.64NH AIR WOUND
L310	2409377M08	IDCTR,CHIP,22NH,5%,700 MA,.19OHM,SM,
L312	2462587V59	IND CHIP 390 NH 5%
L313	2460591E74	COIL AIR WOUND INDUC 31.67
L314	2409377M14	IDCTR,CHIP,68NH,5%,600 MA,.34OHM,SM,
L315	2462587V59	IND CHIP 390 NH 5%
L316	2409377M04	IDCTR,CHIP,10NH,5%,700 MA,.13OHM,SM,
L317	2462587V59	IND CHIP 390 NH 5%
L318	2462587V59	IND CHIP 390 NH 5%
L320	2460591D74	COIL AIR WOUND INDUC 25.19
L321	2409377M16	IDCTR,CHIP,82NH,5%,400 MA,.58OHM,SM,
L402	2460591C24	COIL AIR WOUND INDUC 15.98
L404	2460591C24	COIL AIR WOUND INDUC 15.98
L410	2462587V34	CHIP IND 100 NH 5% 0805
L418	2409154M92	FIXED INDUCTOR,CHIP,22NH,5%, 200MA,.
L420	2409154M01	FIXED INDUCTOR,CHIP,1NH,1OH M,.,1
L430	2409154M92	FIXED INDUCTOR,CHIP,22NH,5%, 200MA,.
L431	2409154M92	FIXED INDUCTOR,CHIP,22NH,5%, 200MA,.
L434	2409377M10	IDCTR,CHIP,33NH,5%,600 MA,.22OHM,SM,
L435	2460591C24	COIL AIR WOUND INDUC 15.98
L436	2462587V34	CHIP IND 100 NH 5% 0805

Ref. Des.	Part Number	Description
L437	2460591C24	COIL AIR WOUND INDUC 15.98
L438	2409154M50	FIXED INDUCTOR,COMP,100NH,5 %,,.5.5OH
L451	2409154M66	FIXED INDUCTOR,CHIP,18NH,55 %,,.7OHM
L452	2409377M36	IDCTR,CHIP,220NH,5%,200 MA,2.1OHM,SM
L453	2462587Q43	IND CHIP 470 NH 10%
L454	2462587T25	IND CHIP 620NH 5% LOW PRO
L455	2409154M67	FIXED INDUCTOR,CHIP,22NH,5%, .8OHM,.
L456	2409154M67	FIXED INDUCTOR,CHIP,22NH,5%, .8OHM,.
L501	2405769X05	COIL INDUCTOR
L502	2405769X05	COIL INDUCTOR
L503	2462587Q54	IND CHIP 3,900 NH 10%
L504	2462587N76	CHIP IND 4700 NH 5%
L508	2462587Q51	IND CHIP 2,200 NH 10%
L542	2404574Z15	IND CHIP WW 330NH 2% 2012 SMD
L550	2462587N59	CHIP IND 330 NH 5%
L701	2460591A50	COIL AIR WOUND INDUC 9.75
L705	2462587T30	IND CHIP 1000NH 5% LOW PRO
L708	2479990C03	AIR WND COIL/GREEN COLOR 13.85
L711	2460591A50	COIL AIR WOUND INDUC 9.75
L715	2460591A50	COIL AIR WOUND INDUC 9.75
L719	2409377M30	IDCTR,CHIP,24NH,5%,700 MA,.135OHM,SM
L720	2462587N68	CHIP IND 1000 NH 5%
P1	NOTPLACED	64AM DUMMY PART NUMBER
PCB	8485325E01	PCB RF UHF RNG 2
Q1	4813821A47	TSTR P-CH HDTMOS 20V

Ref. Des.	Part Number	Description
Q101	4813824A42	TSTR PNP 50V BIAS RES 10K 10K
Q102	4813821A47	TSTR P-CH HDTMOS 20V
Q103	4813824A42	TSTR PNP 50V BIAS RES 10K 10K
Q104	4813821A47	TSTR P-CH HDTMOS 20V
Q105	4805128M12	TSTR SOT BCW 60B (RH)
Q106	4880048M01	TSTR NPN DIG 47K/47K
Q107	5185633C51	MODULE RING TRANSISTOR PWR FET 800MH
Q108	4805128M12	TSTR SOT BCW 60B (RH)
Q2	4880048M01	TSTR NPN DIG 47K/47K
Q201	4880048M01	TSTR NPN DIG 47K/47K
Q301	4805793Y01	TRANS MINI SOT NPN LOW NOISE
Q302	4805793Y01	TRANS MINI SOT NPN LOW NOISE
Q304	4805793Y01	TRANS MINI SOT NPN LOW NOISE
Q305	4809579E16	TSTR MOSFET N-CHAN TN0200T
Q306	4809579E16	TSTR MOSFET N-CHAN TN0200T
Q308	4809579E16	TSTR MOSFET N-CHAN TN0200T
Q310	4813824A42	TSTR PNP 50V BIAS RES 10K 10K
Q311	4813824A39	TSTR NPN 50V BIAS RES 22K 22K
Q428	4805585Q19	TRANSISTOR
Q501	4805128M19	TSTR SOT23 MMBTA13 RH
Q502	4805218N63	RF TRANS SOT 323 Bfq67w
Q503	4813821A47	TSTR P-CH HDTMOS 20V
R1	0662057N23	RES. CHIP 100K 5% 20X40
R101	0662057N23	RES. CHIP 100K 5% 20X40
R102	0662057M01	RES. CHIP 0 5% 20X40
R105	0662057N03	RES. CHIP 15K 5% 20X40
R106	0662057N09	RES. CHIP 27K 5% 20X40
R107	0662057M67	RES. CHIP 510 5% 20X40
R108	0662057M67	RES. CHIP 510 5% 20X40

Ref. Des.	Part Number	Description
R109	0662057A25	CHIP RES 100 OHMS 5%
R110	0662057A25	CHIP RES 100 OHMS 5%
R111	0662057N23	RES. CHIP 100K 5% 20X40
R112	0662057N23	RES. CHIP 100K 5% 20X40
R113	0662057N23	RES. CHIP 100K 5% 20X40
R114	0662057N23	RES. CHIP 100K 5% 20X40
R115	0662057M74	RES. CHIP 1000 5% 20X40
R118	0662057M50	RES. CHIP 100 5% 20X40
R119	0662057M50	RES. CHIP 100 5% 20X40
R120	0662057M50	RES. CHIP 100 5% 20X40
R121	0662057M50	RES. CHIP 100 5% 20X40
R122	0662057M74	RES. CHIP 1000 5% 20X40
R124	0662057N23	RES. CHIP 100K 5% 20X40
R126	0662057M98	RES. CHIP 10K 5% 20X40
R127	0662057M98	RES. CHIP 10K 5% 20X40
R128	0662057M98	RES. CHIP 10K 5% 20X40
R129	0662057M98	RES. CHIP 10K 5% 20X40
R131	NOTPLACED	64AM DUMMY PART NUMBER
R132	0662057M01	RES. CHIP 0 5% 20X40
R201	0662057M91	RES CHIP 5100 5% 20X40
R202	0662057M62	RES. CHIP 330 5% 20X40
R203	0662057M01	RES. CHIP 0 5% 20X40
R204	0662057N15	RES. CHIP 47K 5% 20X40
R205	0662057N10	RES. CHIP 30K 5% 20X40
R207	0662057M60	RES. CHIP 270 5% 20X40
R208	0662057M91	RES CHIP 5100 5% 20X40
R209	0662057N23	RES. CHIP 100K 5% 20X40
R210	0662057M58	RES. CHIP 220 5% 20X40
R211	0662057M74	RES. CHIP 1000 5% 20X40
R212	0662057M48	RES. CHIP 82 5% 20X40
R213	0662057M98	RES. CHIP 10K 5% 20X40
R214	0662057M74	RES. CHIP 1000 5% 20X40
R215	0662057M98	RES. CHIP 10K 5% 20X40
R217	0662057M70	RES. CHIP 680 5% 20X40
R218	0662057M96	RES. CHIP 8200 5% 20X40
R301	0662057N10	RES. CHIP 30K 5% 20X40
R302	0662057M58	RES. CHIP 220 5% 20X40
R303	0662057N07	RES. CHIP 22K 5% 20X40

Ref. Des.	Part Number	Description
R304	0662057M34	RES. CHIP 22 5% 20X40
R305	0662057N16	RES. CHIP 51K 5% 20X40
R306	0662057M26	RES. CHIP 10 5% 20X40
R307	0662057M62	RES. CHIP 330 5% 20X40
R308	0662057M62	RES. CHIP 330 5% 20X40
R312	0662057M38	RES. CHIP 33 5% 20X40
R314	0662057M34	RES. CHIP 22 5% 20X40
R315	0662057M44	RES CHIP 56 5% 20X40
R317	0662057N10	RES. CHIP 30K 5% 20X40
R318	0662057M58	RES. CHIP 220 5% 20X40
R319	0662057N07	RES. CHIP 22K 5% 20X40
R320	0662057M34	RES. CHIP 22 5% 20X40
R321	0662057M62	RES. CHIP 330 5% 20X40
R322	0662057N16	RES. CHIP 51K 5% 20X40
R323	0662057N09	RES. CHIP 27K 5% 20X40
R324	0662057M58	RES. CHIP 220 5% 20X40
R325	0662057N07	RES. CHIP 22K 5% 20X40
R326	0662057M34	RES. CHIP 22 5% 20X40
R327	0662057N16	RES. CHIP 51K 5% 20X40
R332	0662057M92	RES. CHIP 5600 5% 20X40
R333	0662057M58	RES. CHIP 220 5% 20X40
R409	0662057N06	RES. CHIP 20K 5% 20X40
R415	0662057N06	RES. CHIP 20K 5% 20X40
R422	0662057M90	RES. CHIP 4700 5% 20X40
R423	0662057M72	RES. CHIP 820 5% 20X40
R424	0662057M94	RES. CHIP 6800 5% 20X40
R426	0662057M88	RES. CHIP 3900 5% 20X40
R432	0662057M69	RES. CHIP 620 5% 20X40
R433	0662057M01	RES. CHIP 0 5% 20X40
R442	0662057N06	RES. CHIP 20K 5% 20X40
R449	0662057N06	RES. CHIP 20K 5% 20X40
R451	0662057M42	RES. CHIP 47 5% 20X40
R454	0662057M98	RES. CHIP 10K 5% 20X40
R455	0662057M98	RES. CHIP 10K 5% 20X40
R456	0662057M54	RES. CHIP 150 5% 20X40
R501	0662057N17	RES. CHIP 56K 5% 20X40
R502	0662057M56	RES. CHIP 180 5% 20X40
R503	0662057M98	RES. CHIP 10K 5% 20X40

Ref. Des.	Part Number	Description
R506	0662057M98	RES. CHIP 10K 5% 20X40
R507	0662057M81	RES. CHIP 2000 5% 20X40
R508	0662057M62	RES. CHIP 330 5% 20X40
R510	0662057M98	RES. CHIP 10K 5% 20X40
R511	0662057N23	RES. CHIP 100K 5% 20X40
R512	0662057M98	RES. CHIP 10K 5% 20X40
R513	0662057M98	RES. CHIP 10K 5% 20X40
R514	0662057M67	RES. CHIP 510 5% 20X40
R6	0662057M98	RES. CHIP 10K 5% 20X40
R7	0662057M98	RES. CHIP 10K 5% 20X40
R701	0662057A23	CHIP RES 82 OHMS 5%
R702	0662057A23	CHIP RES 82 OHMS 5%
R721	NOTPLACED	64AM DUMMY PART NUMBER
R8	0662057M50	RES. CHIP 100 5% 20X40
SH101	2685074D02	SHIELD PA
SH201	2685787B01	SHLD FRAC-N
SH202	2685787B01	SHLD FRAC-N
SH301	2685297D02	SHIELD VCO
SH302	2685298D01	SHLD VCO BUFFER
SH401	2685071D02	SHIELD 16.8 REFERENCE
SH402	2685153E01	SHEILD LNA
SH450	2685965D01	SHIELD MIXER
SH451	2685070D02	SHIELD COVER, CRYSTAL FILTER
SH501	2685787B01	SHLD FRAC-N
SH502	2685786D01	SHEILD ABACUS 2ND LO
SH701	2685784D01	SHEILD HARMONIC FILTER
T451	2580541Z02	BALUN TRANSFORMER (NEW)
T452	2580541Z02	BALUN TRANSFORMER (NEW)
T453	2585918C01	XFMR SMALL SIGNAL SURFACE MT
U1	5185353D13	IC MINI SO-8 HI PRECISION REG 5V
U102	5185130C65	IC VHF/UHF/800 MHZ LDMOS DRIVER
U103	5185963A15	IC TEMPATURE SENSOR 1M50C
U104	5185765B26	IC PWR CTRL IN MOS20

Ref. Des.	Part Number	Description
U105	5185368C19	IC QUAD 10 BIT A/D CONV
U106	5185963A60	IC OP AMP
U2	5185353D14	IC SOT23-5 HI PRECISION REG 3V
U201	5185956E66	IC,OP AMP,1PER PKG,LMH6723,IC
U202	5185963A27	IC TESTED AT25016 48 PIN GFP
U203	5185368C83	IC 12 BIT DAC
U3	5185353D14	IC SOT23-5 HI PRECISION REG 3V
U300	5105750U54	IC PKG DIE VCO BUFFER
U4	5105462G78	IC EEPROM 16K SPEI CMOS
U451	5185130C91	IC MIXER RF SOIC 10
U5	5185353D14	IC SOT23-5 HI PRECISION REG 3V
U500	5185963A85	IC-ABACUS III-LP
U725	5185130C83	IC 15DB DIGITAL ATTEUATOR SOT25 PKG
U726	5185143E12	IC INVERTER DUAL SC70
U727	4809877C13	DIODE VARACTOR ISV305 SMD
U728	4809877C13	DIODE VARACTOR ISV305 SMD
VR1	4813830A33	DIODE 20V 5% 225MW MMBZ5250B_
VR2	4813830A15	DIODE 5.6V 5% 225MW MMBZ5232B_
VR3	4805656W45	DIODE TRANSIENT VOLTAGE SUPPRESSOR
Y200	4802245J68	OSC, REF 16.8 MHZ 1.5 PPM

### 8.4 VOCON Boards

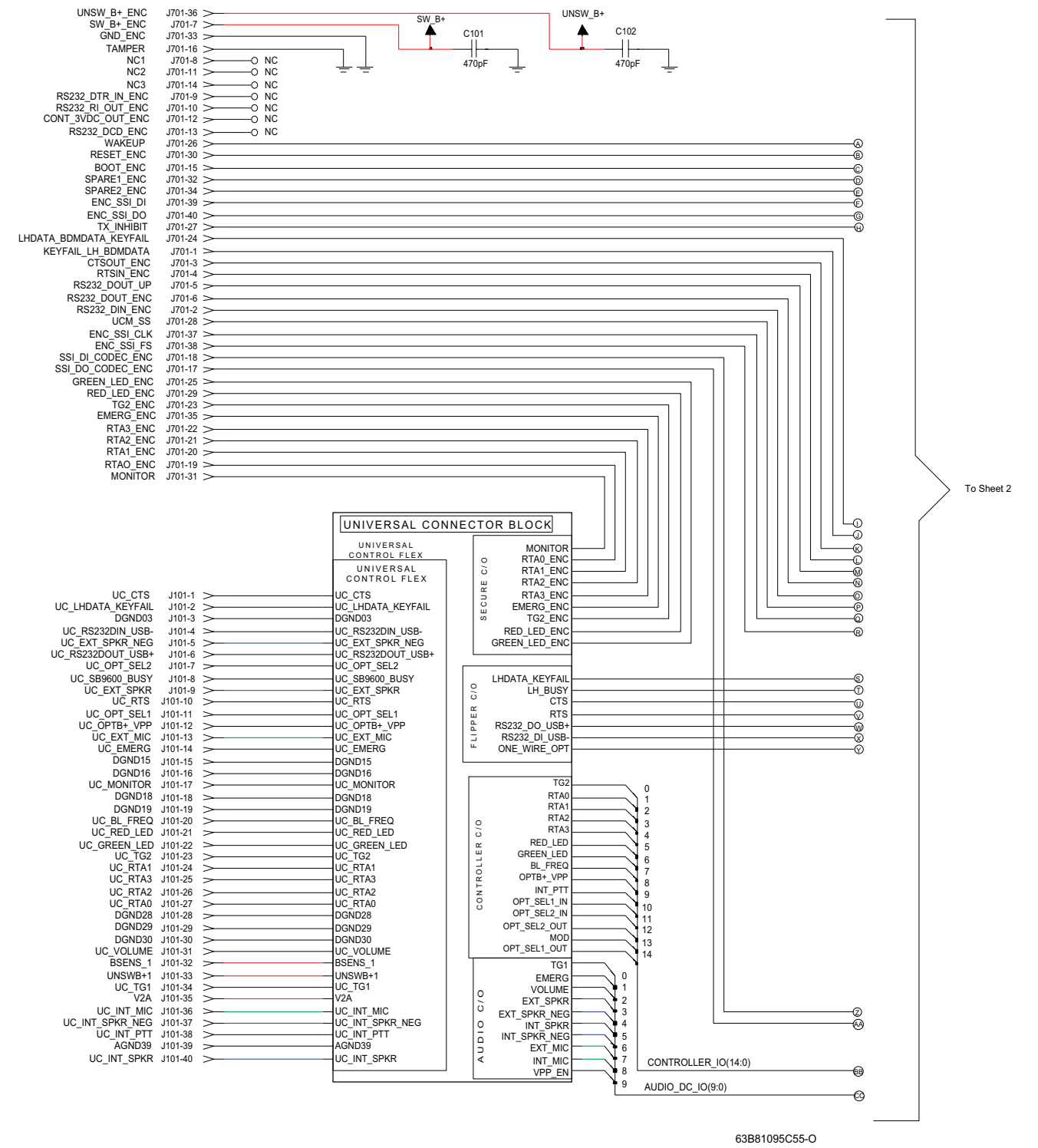

Figure 8-61. NTN9564B VOCON Board Overall Schematic—1 of 2

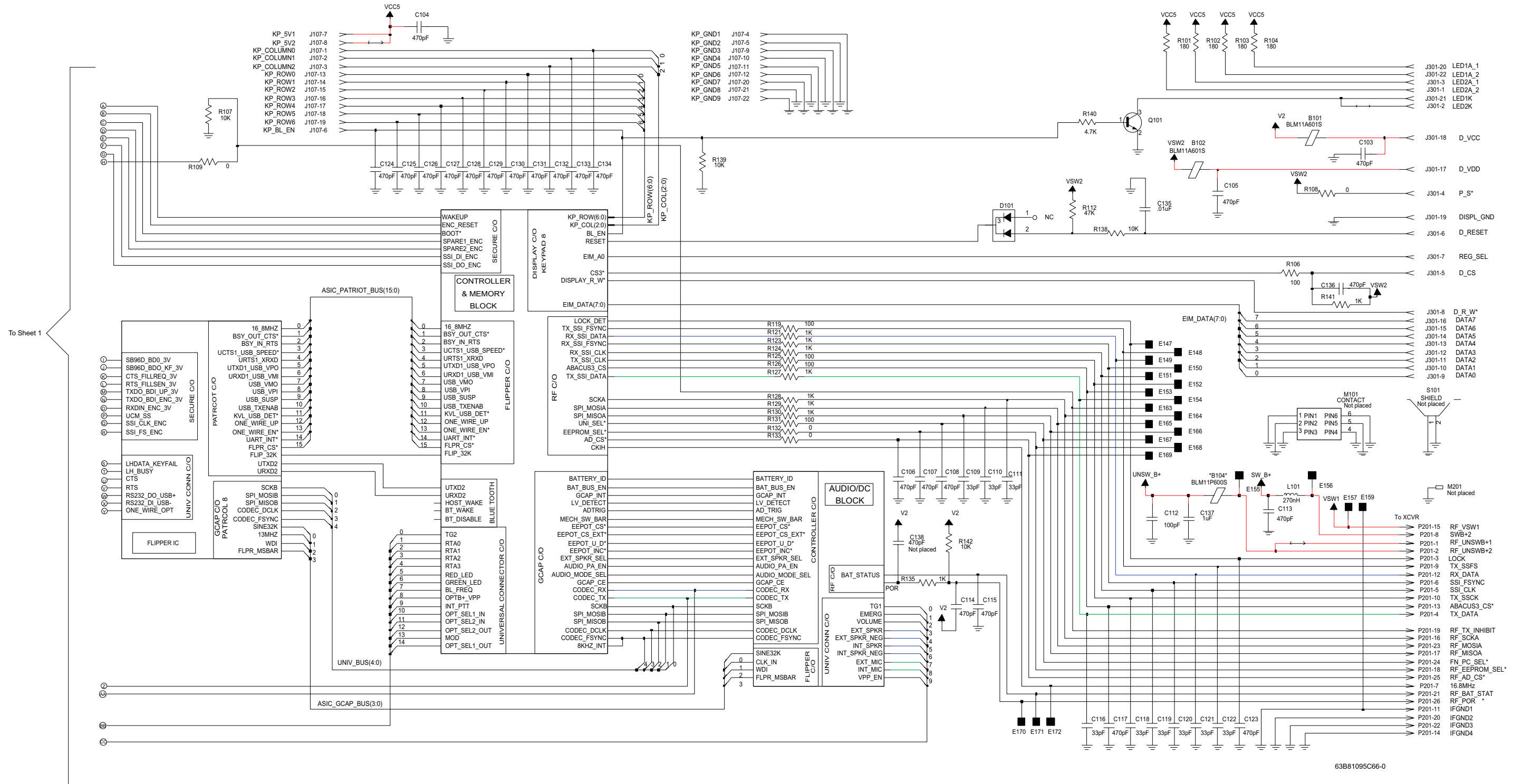

Figure 8-62. NTN9564B VOCON Board Overall Schematic—2 of 2







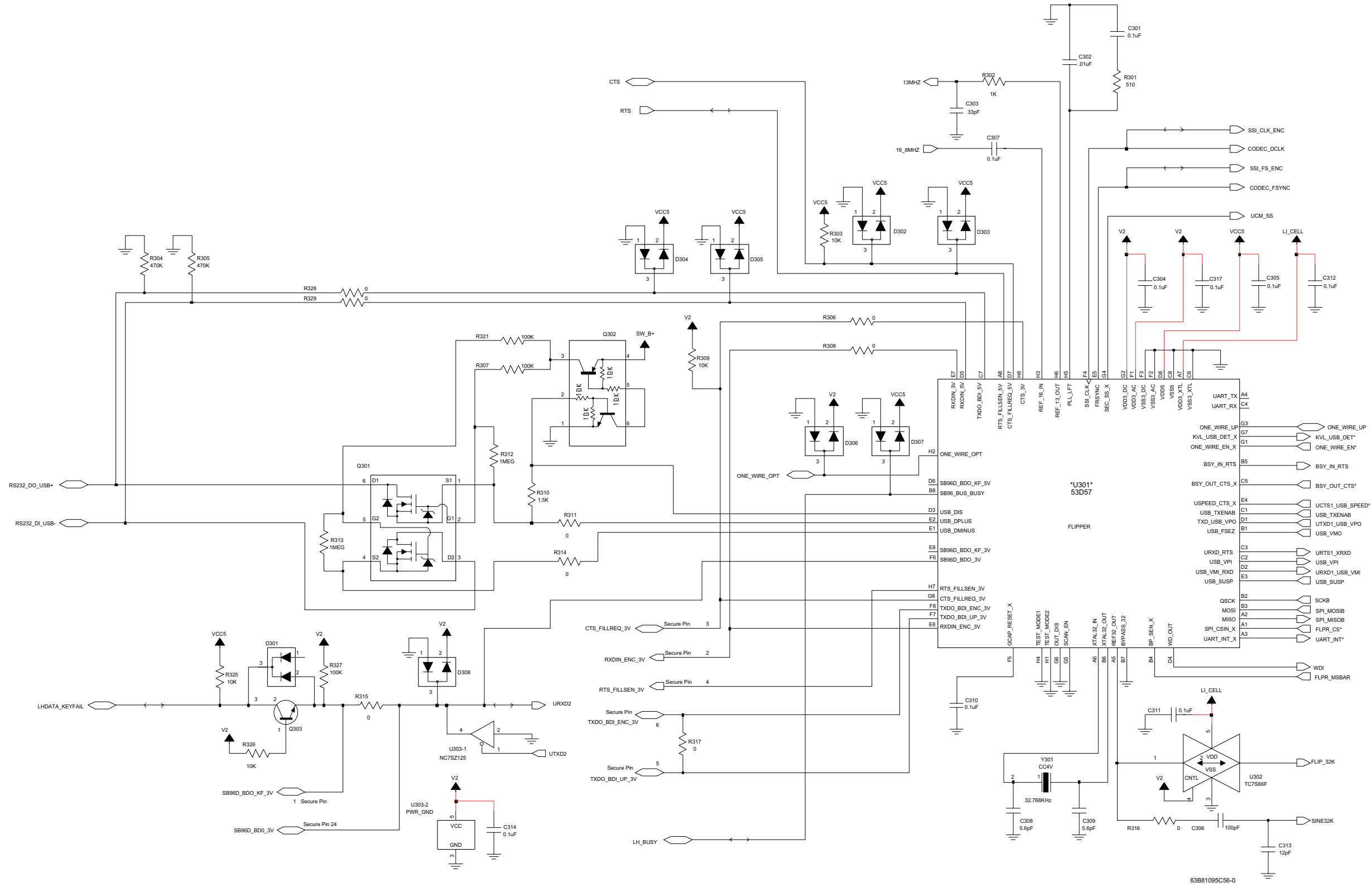

Figure 8-64. NTN9564B VOCON Flipper Circuit

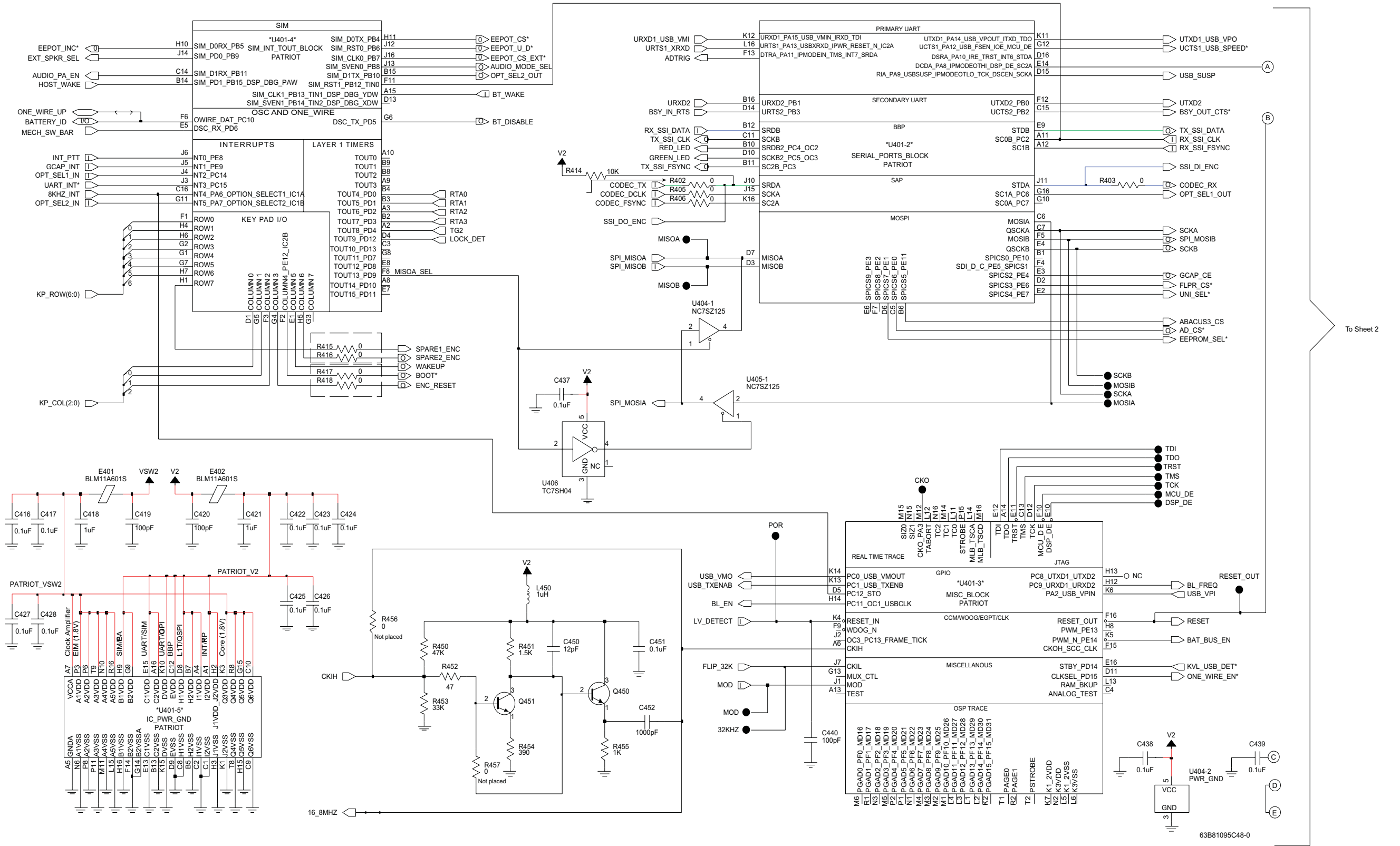

Figure 8-65. NTN9564B VOCON Controller and Memory Circuits—1 of 2

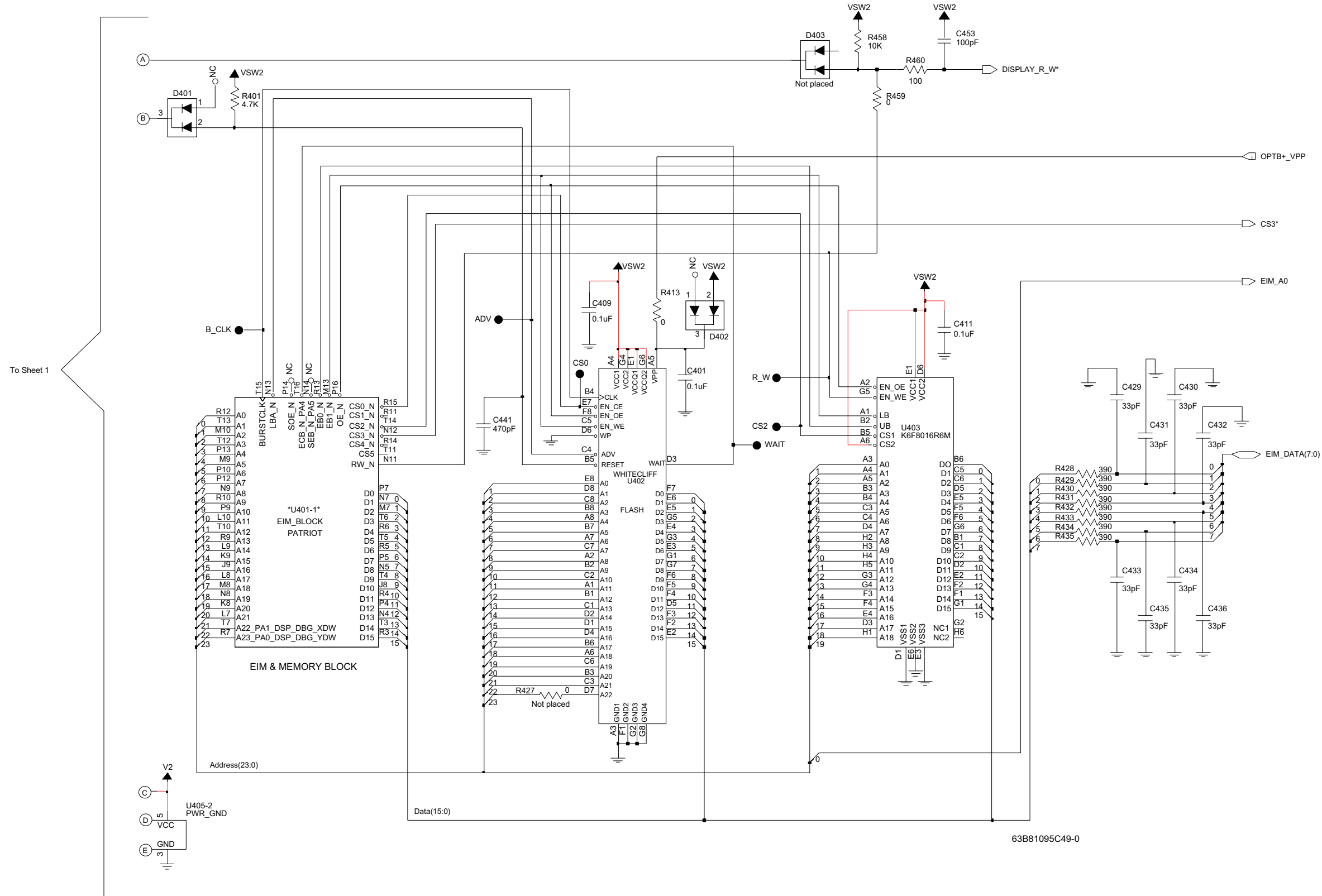

Figure 8-66. NTN9564B VOCON Controller and Memory Circuits—2 of 2

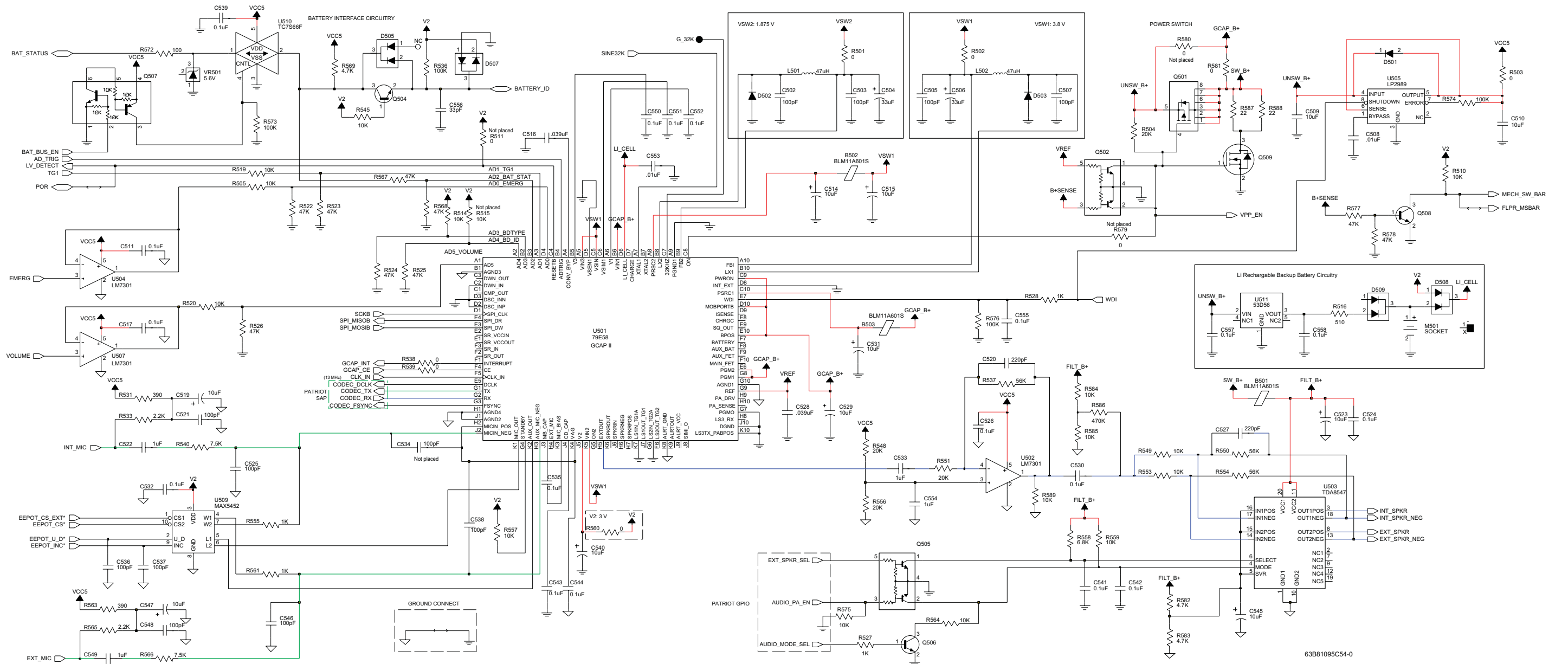
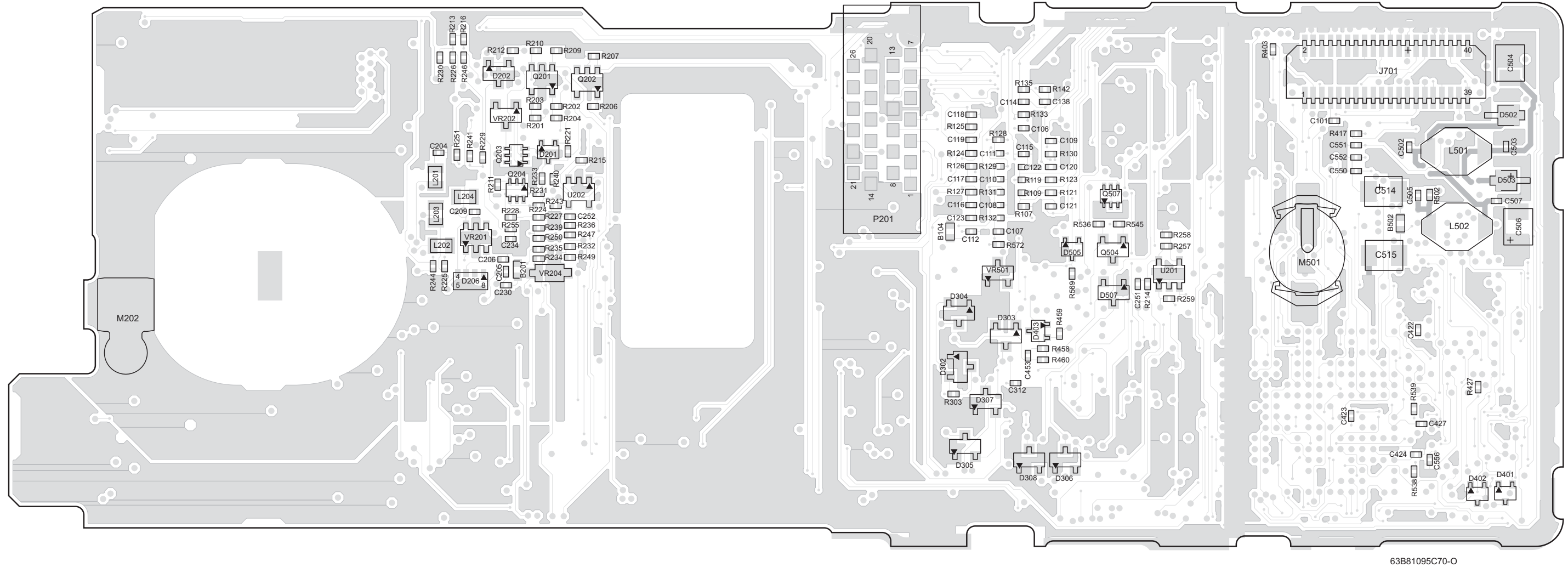

Figure 8-67. NTN9564B VOCON Audio and DC Circuits





63B81095C70-0

Figure 8-69. NTN9564B VOCON Board Layout—Side 2



## NTN9564B VOCON Board Parts List

Ref. Des.	Part Number	Description
—	1105033S13	RIBBON LBL
—	5405569Y01	LBL BARCODE APC
—	5405569Y03	LABEL BARCODE
—	6003710K08	BATT COIN 3.3V LIION
32KHZ	NOTPLACED	NOT PLACED
ADV	NOTPLACED	NOT PLACED
B_CLK	NOTPLACED	NOT PLACED
B101	2480574F01	IND FERRITE CHIP 60OHM 0603
B102	2480574F01	IND FERRITE CHIP 60OHM 0603
B104	2462586G33	INDUCTOR CHIP FERRITE BEADS
B201	2480574F01	IND FERRITE CHIP 60OHM 0603
B501	2480574F01	IND FERRITE CHIP 60OHM 0603
B502	2480574F01	IND FERRITE CHIP 60OHM 0603
B503	2480574F01	IND FERRITE CHIP 60OHM 0603
C101	2113743L09	CAP CHIP 470 PF 10% X7R
C102	2113743L09	CAP CHIP 470 PF 10% X7R
C103	2113743L09	CAP CHIP 470 PF 10% X7R
C104	2113743L09	CAP CHIP 470 PF 10% X7R
C105	2113743L09	CAP CHIP 470 PF 10% X7R
C106	2113743L09	CAP CHIP 470 PF 10% X7R
C107	2113743L09	CAP CHIP 470 PF 10% X7R
C108	2113743L09	CAP CHIP 470 PF 10% X7R
C109	2113743N38	CAP CHIP 33.0 PF 5% COG
C110	2113743N38	CAP CHIP 33.0 PF 5% COG
C111	2113743N38	CAP CHIP 33.0 PF 5% COG
C112	2113743N50	CAP CHIP 100 PF 5% COG
C113	2113743L09	CAP CHIP 470 PF 10% X7R
C114	2113743L09	CAP CHIP 470 PF 10% X7R
C115	2113743L09	CAP CHIP 470 PF 10% X7R
C116	2113743N38	CAP CHIP 33.0 PF 5% COG
C117	2113743L09	CAP CHIP 470 PF 10% X7R
C118	2113743N38	CAP CHIP 33.0 PF 5% COG
C119	2113743N38	CAP CHIP 33.0 PF 5% COG

Ref. Des.	Part Number	Description
C120	2113743N38	CAP CHIP 33.0 PF 5% COG
C121	2113743N38	CAP CHIP 33.0 PF 5% COG
C122	2113743N38	CAP CHIP 33.0 PF 5% COG
C123	2113743L09	CAP CHIP 470 PF 10% X7R
C124	2113743L09	CAP CHIP 470 PF 10% X7R
C125	2113743L09	CAP CHIP 470 PF 10% X7R
C126	2113743L09	CAP CHIP 470 PF 10% X7R
C127	2113743L09	CAP CHIP 470 PF 10% X7R
C128	2113743L09	CAP CHIP 470 PF 10% X7R
C129	2113743L09	CAP CHIP 470 PF 10% X7R
C130	2113743L09	CAP CHIP 470 PF 10% X7R
C131	2113743L09	CAP CHIP 470 PF 10% X7R
C132	2113743L09	CAP CHIP 470 PF 10% X7R
C133	2113743L09	CAP CHIP 470 PF 10% X7R
C134	2113743L09	CAP CHIP 470 PF 10% X7R
C135	2113743L41	CAP CHIP 10000 PF 10% X7R
C136	2113743L09	CAP CHIP 470 PF 10% X7R
C137	2113743A31	CAP CHIP 1.0UF 10% X7R
C138	NOTPLACED	NOT PLACED
C201	2113743L09	CAP CHIP 470 PF 10% X7R
C202	2113743L09	CAP CHIP 470 PF 10% X7R
C203	2113743L09	CAP CHIP 470 PF 10% X7R
C204	2113743L09	CAP CHIP 470 PF 10% X7R
C205	2113743L41	CAP CHIP 10000 PF 10% X7R
C206	2113743L41	CAP CHIP 10000 PF 10% X7R
C207	2113743L09	CAP CHIP 470 PF 10% X7R
C208	2113743L09	CAP CHIP 470 PF 10% X7R
C209	2113743L41	CAP CHIP 10000 PF 10% X7R
C210	2113743L09	CAP CHIP 470 PF 10% X7R
C211	2113743L09	CAP CHIP 470 PF 10% X7R
C212	2113743L09	CAP CHIP 470 PF 10% X7R
C213	2113743L09	CAP CHIP 470 PF 10% X7R
C214	2113743L09	CAP CHIP 470 PF 10% X7R
C215	2113743L09	CAP CHIP 470 PF 10% X7R
C216	2113743L09	CAP CHIP 470 PF 10% X7R
C217	2113743L09	CAP CHIP 470 PF 10% X7R

Ref. Des.	Part Number	Description
C218	2113743L09	CAP CHIP 470 PF 10% X7R
C219	2113743L09	CAP CHIP 470 PF 10% X7R
C220	2113743L09	CAP CHIP 470 PF 10% X7R
C221	2113743L09	CAP CHIP 470 PF 10% X7R
C223	2113743L09	CAP CHIP 470 PF 10% X7R
C224	2113743N38	CAP CHIP 33.0 PF 5% COG
C225	2113743L09	CAP CHIP 470 PF 10% X7R
C226	2113743L09	CAP CHIP 470 PF 10% X7R
C227	2113743L09	CAP CHIP 470 PF 10% X7R
C230	2113743M24	CAP CHIP 100000 PF +80-20% Y5V
C231	2113743L09	CAP CHIP 470 PF 10% X7R
C232	2113743L09	CAP CHIP 470 PF 10% X7R
C233	2113743N50	CAP CHIP 100 PF 5% COG
C234	2113743M24	CAP CHIP 100000 PF +80-20% Y5V
C250	2113743L41	CAP CHIP 10000 PF 10% X7R
C251	2113743M24	CAP CHIP 100000 PF +80-20% Y5V
C252	2113743M24	CAP CHIP 100000 PF +80-20% Y5V
C301	2113932E20	CAP CER CHP .10 UF 10% 16V
C302	2113743L41	CAP CHIP 10000 PF 10% X7R
C303	2113743N38	CAP CHIP 33.0 PF 5% COG
C304	2113743M24	CAP CHIP 100000 PF +80-20% Y5V
C305	2113743M24	CAP CHIP 100000 PF +80-20% Y5V
C306	2113743N50	CAP CHIP 100 PF 5% COG
C307	2113743M24	CAP CHIP 100000 PF +80-20% Y5V
C308	2113743N20	CAP CHIP 5.6PF +-.5PF COG
C309	2113743N20	CAP CHIP 5.6PF +-.5PF COG
C310	2113743M24	CAP CHIP 100000 PF +80-20% Y5V
C311	2113743M24	CAP CHIP 100000 PF +80-20% Y5V

Ref. Des.	Part Number	Description
C312	2113743M24	CAP CHIP 100000 PF +80-20% Y5V
C313	2113743N28	CAP CHIP 12.0 PF 5% COG
C314	2113743M24	CAP CHIP 100000 PF +80-20% Y5V
C317	2113743M24	CAP CHIP 100000 PF +80-20% Y5V
C401	2113743M24	CAP CHIP 100000 PF +80-20% Y5V
C409	2113743M24	CAP CHIP 100000 PF +80-20% Y5V
C411	2113743M24	CAP CHIP 100000 PF +80-20% Y5V
C416	2113743M24	CAP CHIP 100000 PF +80-20% Y5V
C417	2113743M24	CAP CHIP 100000 PF +80-20% Y5V
C418	2113743A31	CAP CHIP 1.0UF 10% X7R
C419	2113743N50	CAP CHIP 100 PF 5% COG
C420	2113743N50	CAP CHIP 100 PF 5% COG
C421	2113743A31	CAP CHIP 1.0UF 10% X7R
C422	2113743M24	CAP CHIP 100000 PF +80-20% Y5V
C423	2113743M24	CAP CHIP 100000 PF +80-20% Y5V
C424	2113743M24	CAP CHIP 100000 PF +80-20% Y5V
C425	2113743M24	CAP CHIP 100000 PF +80-20% Y5V
C426	2113743M24	CAP CHIP 100000 PF +80-20% Y5V
C427	2113743M24	CAP CHIP 100000 PF +80-20% Y5V
C428	2113743M24	CAP CHIP 100000 PF +80-20% Y5V
C429	2113743N38	CAP CHIP 33.0 PF 5% COG
C430	2113743N38	CAP CHIP 33.0 PF 5% COG
C431	2113743N38	CAP CHIP 33.0 PF 5% COG
C432	2113743N38	CAP CHIP 33.0 PF 5% COG
C433	2113743N38	CAP CHIP 33.0 PF 5% COG
C434	2113743N38	CAP CHIP 33.0 PF 5% COG
C435	2113743N38	CAP CHIP 33.0 PF 5% COG
C436	2113743N38	CAP CHIP 33.0 PF 5% COG

Ref. Des.	Part Number	Description
C437	2113743M24	CAP CHIP 100000 PF +80-20% Y5V
C438	2113743M24	CAP CHIP 100000 PF +80-20% Y5V
C439	2113743M24	CAP CHIP 100000 PF +80-20% Y5V
C440	2113743N50	CAP CHIP 100 PF 5% COG
C441	2113743L09	CAP CHIP 470 PF 10% X7R
C450	2113743N28	CAP CHIP 12.0 PF 5% COG
C451	2113932E20	CAP CER CHP .10 UF 10% 16V
C452	2113743L17	CAP CHIP 1000 PF 10% X7R
C453	2113743N50	CAP CHIP 100 PF 5% COG
C502	2113743N50	CAP CHIP 100 PF 5% COG
C503	2113743N50	CAP CHIP 100 PF 5% COG
C504	2311049C52	CAP TANT CHIP 33UF 10% 10V
C505	2113743N50	CAP CHIP 100 PF 5% COG
C506	2311049C52	CAP TANT CHIP 33UF 10% 10V
C507	2113743N50	CAP CHIP 100 PF 5% COG
C508	2113743L41	CAP CHIP 10000 PF 10% X7R
C509	2113743T19	CAP 10UF 16V CER 3225 X5R
C510	2113743T19	CAP 10UF 16V CER 3225 X5R
C511	2113743M24	CAP CHIP 100000 PF +80-20% Y5V
C514	2311049A57	CAP TANT CHIP A/P 10UF 10% 16V
C515	2311049A57	CAP TANT CHIP A/P 10UF 10% 16V
C516	2113743E11	CAP CHIP .039 UF 10% X7R
C517	2113743M24	CAP CHIP 100000 PF +80-20% Y5V
C519	2311049A57	CAP TANT CHIP A/P 10UF 10% 16V
C520	2113743L01	CAP CHIP 220 PF 10% X7R
C521	2113743N50	CAP CHIP 100 PF 5% COG
C522	2113743A31	CAP CHIP 1.0UF 10% X7R

Ref. Des.	Part Number	Description
C523	2311049A57	CAP TANT CHIP A/P 10UF 10% 16V
C524	2113743M24	CAP CHIP 100000 PF +80-20% Y5V
C525	2113743N50	CAP CHIP 100 PF 5% COG
C526	2113743M24	CAP CHIP 100000 PF +80-20% Y5V
C527	2113743L01	CAP CHIP 220 PF 10% X7R
C528	2113743E11	CAP CHIP .039 UF 10% X7R
C529	2311049A57	CAP TANT CHIP A/P 10UF 10% 16V
C530	2113743A19	CAP CHIP .100 UF 10% X7R
C531	2311049A57	CAP TANT CHIP A/P 10UF 10% 16V
C532	2113743M24	CAP CHIP 100000 PF +80-20% Y5V
C533	2113743A31	CAP CHIP 1.0UF 10% X7R
C534	NOTPLACED	NOT PLACED
C535	2113743M24	CAP CHIP 100000 PF +80-20% Y5V
C536	2113743N50	CAP CHIP 100 PF 5% COG
C537	2113743N50	CAP CHIP 100 PF 5% COG
C538	2113743N50	CAP CHIP 100 PF 5% COG
C539	2113743M24	CAP CHIP 100000 PF +80-20% Y5V
C540	2311049A57	CAP TANT CHIP A/P 10UF 10% 16V
C541	2113743M24	CAP CHIP 100000 PF +80-20% Y5V
C542	2113743M24	CAP CHIP 100000 PF +80-20% Y5V
C543	2113743M24	CAP CHIP 100000 PF +80-20% Y5V
C544	2113743M24	CAP CHIP 100000 PF +80-20% Y5V
C545	2311049A57	CAP TANT CHIP A/P 10UF 10% 16V
C546	2113743N50	CAP CHIP 100 PF 5% COG
C547	2311049A57	CAP TANT CHIP A/P 10UF 10% 16V
C548	2113743N50	CAP CHIP 100 PF 5% COG
C549	2113743A31	CAP CHIP 1.0UF 10% X7R

Ref. Des.	Part Number	Description
C550	2113743M24	CAP CHIP 100000 PF +80-20% Y5V
C551	2113743M24	CAP CHIP 100000 PF +80-20% Y5V
C552	2113743M24	CAP CHIP 100000 PF +80-20% Y5V
C553	2113743L41	CAP CHIP 10000 PF 10% X7R
C554	2113743A31	CAP CHIP 1.0UF 10% X7R
C555	2113743M24	CAP CHIP 100000 PF +80-20% Y5V
C556	2113743N38	CAP CHIP 33.0 PF 5% COG
C557	2113743M24	CAP CHIP 100000 PF +80-20% Y5V
C558	2113743M24	CAP CHIP 100000 PF +80-20% Y5V
CKO	NOTPLACED	NOT PLACED
CS0	NOTPLACED	NOT PLACED
CS2	NOTPLACED	NOT PLACED
D101	4805218N57	DIODE DUAL
D201	NOTPLACED	NOT PLACED
D202	4805129M90	DIODE SOT PKGD
D203	4802021P15	ZENER SR05
D204	4805656W39	QUAD ESD SUPPRESSOR ARRAY -41206ESDA
D205	4805656W39	QUAD ESD SUPPRESSOR ARRAY -41206ESDA
D206	4805656W39	QUAD ESD SUPPRESSOR ARRAY -41206ESDA
D207	4805129M90	DIODE SOT PKGD
D301	4805218N57	DIODE DUAL
D302	4805129M06	DIODE MMBD7000
D303	4805129M06	DIODE MMBD7000
D304	4805129M06	DIODE MMBD7000
D305	4805129M06	DIODE MMBD7000
D306	4805129M06	DIODE MMBD7000
D307	4805129M06	DIODE MMBD7000
D308	4805129M06	DIODE MMBD7000
D401	4805218N57	DIODE DUAL
D402	4805218N57	DIODE DUAL
D403	NOTPLACED	NOT PLACED

Ref. Des.	Part Number	Description
D501	4813833A20	DIODE SCHOTTKY 1A 40V PWRMITE
D502	4813833A20	DIODE SCHOTTKY 1A 40V PWRMITE
D503	4813833A20	DIODE SCHOTTKY 1A 40V PWRMITE
D505	4805218N57	DIODE DUAL
D507	4805129M06	DIODE MMBD7000
D508	4805218N57	DIODE DUAL
D509	4805218N57	DIODE DUAL
DSP_DE	NOTPLACED	NOT PLACED
E147	NOTPLACED	NOT PLACED
E148	NOTPLACED	NOT PLACED
E149	NOTPLACED	NOT PLACED
E150	NOTPLACED	NOT PLACED
E151	NOTPLACED	NOT PLACED
E152	NOTPLACED	NOT PLACED
E153	NOTPLACED	NOT PLACED
E154	NOTPLACED	NOT PLACED
E155	NOTPLACED	NOT PLACED
E156	NOTPLACED	NOT PLACED
E157	NOTPLACED	NOT PLACED
E159	NOTPLACED	NOT PLACED
E163	NOTPLACED	NOT PLACED
E164	NOTPLACED	NOT PLACED
E165	NOTPLACED	NOT PLACED
E166	NOTPLACED	NOT PLACED
E167	NOTPLACED	NOT PLACED
E168	NOTPLACED	NOT PLACED
E169	NOTPLACED	NOT PLACED
E170	NOTPLACED	NOT PLACED
E171	NOTPLACED	NOT PLACED
E172	NOTPLACED	NOT PLACED
E201	NOTPLACED	NOT PLACED
E202	NOTPLACED	NOT PLACED
E206	NOTPLACED	NOT PLACED
E207	NOTPLACED	NOT PLACED
E208	NOTPLACED	NOT PLACED
E209	NOTPLACED	NOT PLACED
E210	NOTPLACED	NOT PLACED



Ref. Des.	Part Number	Description
E211	NOTPLACED	NOT PLACED
E212	NOTPLACED	NOT PLACED
E213	NOTPLACED	NOT PLACED
E214	NOTPLACED	NOT PLACED
E215	NOTPLACED	NOT PLACED
E401	2480574F01	IND FERRITE CHIP 60OHM 0603
E402	2480574F01	IND FERRITE CHIP 60OHM 0603
G_32K	NOTPLACED	NOT PLACED
J101	0985185D01	CONN RECEP 0.5MM PITCH 40 CKTS
J107	0987817K01	RECP BTB 0.5P 1.5 STACK SMD
J301	0987817K01	RECP BTB 0.5P 1.5 STACK SMD
J701	0980423L02	40PIN ROBIN CONN 3MM
L101	2404574Z14	IND CHIP WW 270NH 2% 2012 SMD
L201	2404574Z14	IND CHIP WW 270NH 2% 2012 SMD
L202	2404574Z14	IND CHIP WW 270NH 2% 2012 SMD
L203	2404574Z14	IND CHIP WW 270NH 2% 2012 SMD
L204	2404574Z14	IND CHIP WW 270NH 2% 2012 SMD
L205	2404574Z14	IND CHIP WW 270NH 2% 2012 SMD
L206	2404574Z14	IND CHIP WW 270NH 2% 2012 SMD
L207	2404574Z14	IND CHIP WW 270NH 2% 2012 SMD
L208	2404574Z14	IND CHIP WW 270NH 2% 2012 SMD
L209	2404574Z14	IND CHIP WW 270NH 2% 2012 SMD
L210	2404574Z14	IND CHIP WW 270NH 2% 2012 SMD
L450	2462587N68	CHIP IND 1000 NH 5%
L501	2486085A06	COIL 47UH SMT POWER INDUCTOR
L502	2486085A06	COIL 47UH SMT POWER INDUCTOR

Ref. Des.	Part Number	Description
M101	NOTPLACED	NOT PLACED
M201	NOTPLACED	NOT PLACED
M202	3985951A01	CONTACT ANTENNA GROUND
M501	0985888K02	SKT RTC BTTY LEAP
MCU_DE	NOTPLACED	NOT PLACED
MISOA	NOTPLACED	NOT PLACED
MISOB	NOTPLACED	NOT PLACED
MOD	NOTPLACED	NOT PLACED
MOSIA	NOTPLACED	NOT PLACED
MOSIB	NOTPLACED	NOT PLACED
P201	NOTPLACED	NOT PLACED
PCB	8485140D01	BD VOCON XTS5000
POR	NOTPLACED	NOT PLACED
Q101	4813824A10	TSTR NPN 40V .2A GEN PURP
Q201	4805921T09	XSTR DUAL ROHM FMG8
Q202	4805921T09	XSTR DUAL ROHM FMG8
Q204	4805723X03	TRANS DUAL NPN-PNP UMD3N ROHM
Q301	4809579E35	TSTR FET DUAL N-CHAN FDG3601N
Q302	4805723X03	TRANS DUAL NPN-PNP UMD3N ROHM
Q303	4813824A10	TSTR NPN 40V .2A GEN PURP
Q450	4805793Y01	TRANS MINI SOT NPN LOW NOISE
Q451	4805793Y01	TRANS MINI SOT NPN LOW NOISE
Q501	4885844C01	XSTR FET
Q502	4805921T09	XSTR DUAL ROHM FMG8
Q504	4813824A10	TSTR NPN 40V .2A GEN PURP
Q505	4805921T09	XSTR DUAL ROHM FMG8
Q506	4813824A10	TSTR NPN 40V .2A GEN PURP
Q507	4805723X03	TRANS DUAL NPN-PNP UMD3N ROHM
Q508	4813824A10	TSTR NPN 40V .2A GEN PURP
Q509	4805218N11	XISTOR SOT RH BST82

Ref. Des.	Part Number	Description
R_W	NOTPLACED	NOT PLACED
R101	0662057M56	RES. CHIP 180 5% 20X40
R102	0662057M56	RES. CHIP 180 5% 20X40
R103	0662057M56	RES. CHIP 180 5% 20X40
R104	0662057M56	RES. CHIP 180 5% 20X40
R106	0662057M50	RES. CHIP 100 5% 20X40
R107	0662057M98	RES. CHIP 10K 5% 20X40
R108	0662057M01	RES. CHIP 0 5% 20X40
R109	NOTPLACED	NOT PLACED
R112	0662057N15	RES. CHIP 47K 5% 20X40
R119	0662057M50	RES. CHIP 100 5% 20X40
R121	0662057M74	RES. CHIP 1000 5% 20X40
R123	0662057M74	RES. CHIP 1000 5% 20X40
R124	0662057M74	RES. CHIP 1000 5% 20X40
R125	0662057M50	RES. CHIP 100 5% 20X40
R126	0662057M50	RES. CHIP 100 5% 20X40
R127	0662057M74	RES. CHIP 1000 5% 20X40
R128	0662057M74	RES. CHIP 1000 5% 20X40
R129	0662057M74	RES. CHIP 1000 5% 20X40
R130	0662057M74	RES. CHIP 1000 5% 20X40
R131	0662057M50	RES. CHIP 100 5% 20X40
R132	0662057M01	RES. CHIP 0 5% 20X40
R133	0662057M01	RES. CHIP 0 5% 20X40
R135	0662057M74	RES. CHIP 1000 5% 20X40
R138	0662057M98	RES. CHIP 10K 5% 20X40
R139	0662057M98	RES. CHIP 10K 5% 20X40
R140	0662057M90	RES. CHIP 4700 5% 20X40
R141	0662057M74	RES. CHIP 1000 5% 20X40
R142	0662057M98	RES. CHIP 10K 5% 20X40
R201	NOTPLACED	NOT PLACED
R202	NOTPLACED	NOT PLACED
R203	0662057M61	RES. CHIP 300 5% 20X40
R204	0662057M60	RES. CHIP 270 5% 20X40
R205	0662057M98	RES. CHIP 10K 5% 20X40
R206	0662057M37	20X40 30 OMH 5% CHIP RESISTOR
R207	0662057M98	RES. CHIP 10K 5% 20X40
R209	0662057M98	RES. CHIP 10K 5% 20X40
R210	0662057M98	RES. CHIP 10K 5% 20X40

Ref. Des.	Part Number	Description
R211	0662057N23	RES. CHIP 100K 5% 20X40
R212	0662057M46	RES. CHIP 68 5% 20X40
R213	0662057N15	RES. CHIP 47K 5% 20X40
R214	0662057M98	RES. CHIP 10K 5% 20X40
R215	0662057M98	RES. CHIP 10K 5% 20X40
R216	0662057M90	RES. CHIP 4700 5% 20X40
R217	0662057M64	RES. CHIP 390 5% 20X40
R218	0662057M64	RES. CHIP 390 5% 20X40
R221	0662057M01	RES. CHIP 0 5% 20X40
R224	0662057N17	RES. CHIP 56K 5% 20X40
R225	0662057M98	RES. CHIP 10K 5% 20X40
R226	0662057M98	RES. CHIP 10K 5% 20X40
R227	0662057M98	RES. CHIP 10K 5% 20X40
R228	0662057M98	RES. CHIP 10K 5% 20X40
R229	0662057M98	RES. CHIP 10K 5% 20X40
R230	0662057N23	RES. CHIP 100K 5% 20X40
R231	0662057M74	RES. CHIP 1000 5% 20X40
R232	0662057M74	RES. CHIP 1000 5% 20X40
R233	0662057M74	RES. CHIP 1000 5% 20X40
R234	0662057M74	RES. CHIP 1000 5% 20X40
R235	0662057M74	RES. CHIP 1000 5% 20X40
R236	0662057M74	RES. CHIP 1000 5% 20X40
R237	0662057M56	RES. CHIP 180 5% 20X40
R239	0662057M74	RES. CHIP 1000 5% 20X40
R240	0662057M98	RES. CHIP 10K 5% 20X40
R241	0662057M74	RES. CHIP 1000 5% 20X40
R242	0662057M64	RES. CHIP 390 5% 20X40
R243	0662057N06	RES. CHIP 20K 5% 20X40
R244	0662057M74	RES. CHIP 1000 5% 20X40
R245	0662057M74	RES. CHIP 1000 5% 20X40
R246	NOTPLACED	NOT PLACED
R247	NOTPLACED	NOT PLACED
R248	0662057M74	RES. CHIP 1000 5% 20X40
R249	0662057N39	RES. CHIP 470K 5% 20X40
R250	NOTPLACED	NOT PLACED
R251	NOTPLACED	NOT PLACED
R252	0662057M34	RES. CHIP 22 5% 20X40
R253	0662057M34	RES. CHIP 22 5% 20X40
R255	0662057M50	RES. CHIP 100 5% 20X40

Ref. Des.	Part Number	Description
R256	0662057M50	RES. CHIP 100 5% 20X40
R257	0662057N06	RES. CHIP 20K 5% 20X40
R258	0662057N06	RES. CHIP 20K 5% 20X40
R259	NOTPLACED	NOT PLACED
R301	0662057M67	RES. CHIP 510 5% 20X40
R302	0662057M74	RES. CHIP 1000 5% 20X40
R303	0662057M98	RES. CHIP 10K 5% 20X40
R304	0662057N39	RES. CHIP 470K 5% 20X40
R305	0662057N39	RES. CHIP 470K 5% 20X40
R306	0662057M01	RES. CHIP 0 5% 20X40
R307	0662057N23	RES. CHIP 100K 5% 20X40
R308	0662057M01	RES. CHIP 0 5% 20X40
R309	0662057M98	RES. CHIP 10K 5% 20X40
R310	0662057M78	RES. CHIP 1500 5% 20X40
R311	0662057M01	RES. CHIP 0 5% 20X40
R312	0662057N47	RES. CHIP 1.0 MEG 5% 20X40
R313	0662057N47	RES. CHIP 1.0 MEG 5% 20X40
R314	0662057M01	RES. CHIP 0 5% 20X40
R315	0662057M01	RES. CHIP 0 5% 20X40
R316	0662057M01	RES. CHIP 0 5% 20X40
R317	0662057M01	RES. CHIP 0 5% 20X40
R321	0662057N23	RES. CHIP 100K 5% 20X40
R325	0662057M98	RES. CHIP 10K 5% 20X40
R326	0662057M98	RES. CHIP 10K 5% 20X40
R327	0662057N23	RES. CHIP 100K 5% 20X40
R328	0662057M01	RES. CHIP 0 5% 20X40
R329	0662057M01	RES. CHIP 0 5% 20X40
R401	0662057M90	RES. CHIP 4700 5% 20X40
R402	0662057M01	RES. CHIP 0 5% 20X40
R403	0662057M01	RES. CHIP 0 5% 20X40
R405	0662057M01	RES. CHIP 0 5% 20X40
R406	0662057M01	RES. CHIP 0 5% 20X40
R413	0662057M01	RES. CHIP 0 5% 20X40
R414	0662057M98	RES. CHIP 10K 5% 20X40
R415	0662057M01	RES. CHIP 0 5% 20X40
R416	0662057M01	RES. CHIP 0 5% 20X40
R417	0662057M01	RES. CHIP 0 5% 20X40

Ref. Des.	Part Number	Description
R418	0662057M01	RES. CHIP 0 5% 20X40
R427	NOTPLACED	NOT PLACED
R428	0662057M64	RES. CHIP 390 5% 20X40
R429	0662057M64	RES. CHIP 390 5% 20X40
R430	0662057M64	RES. CHIP 390 5% 20X40
R431	0662057M64	RES. CHIP 390 5% 20X40
R432	0662057M64	RES. CHIP 390 5% 20X40
R433	0662057M64	RES. CHIP 390 5% 20X40
R434	0662057M64	RES. CHIP 390 5% 20X40
R435	0662057M64	RES. CHIP 390 5% 20X40
R450	0662057N15	RES. CHIP 47K 5% 20X40
R451	0662057M78	RES. CHIP 1500 5% 20X40
R452	0662057M42	RES. CHIP 47 5% 20X40
R453	0662057N11	RES. CHIP 33K 5% 20X40
R454	0662057M64	RES. CHIP 390 5% 20X40
R455	0662057M74	RES. CHIP 1000 5% 20X40
R456	NOTPLACED	NOT PLACED
R457	NOTPLACED	NOT PLACED
R458	0662057M98	RES. CHIP 10K 5% 20X40
R459	0662057M01	RES. CHIP 0 5% 20X40
R460	0662057M50	RES. CHIP 100 5% 20X40
R501	0662057M01	RES. CHIP 0 5% 20X40
R502	0662057M01	RES. CHIP 0 5% 20X40
R503	0662057M01	RES. CHIP 0 5% 20X40
R504	0662057N06	RES. CHIP 20K 5% 20X40
R505	0662057M98	RES. CHIP 10K 5% 20X40
R510	0662057M98	RES. CHIP 10K 5% 20X40
R511	NOTPLACED	NOT PLACED
R514	0662057M98	RES. CHIP 10K 5% 20X40
R515	NOTPLACED	NOT PLACED
R516	0662057M67	RES. CHIP 510 5% 20X40
R519	0662057M98	RES. CHIP 10K 5% 20X40
R520	0662057M98	RES. CHIP 10K 5% 20X40
R522	0662057N15	RES. CHIP 47K 5% 20X40
R523	0662057N15	RES. CHIP 47K 5% 20X40
R524	0662057N15	RES. CHIP 47K 5% 20X40
R525	0662057N15	RES. CHIP 47K 5% 20X40
R526	0662057N15	RES. CHIP 47K 5% 20X40
R527	0662057M74	RES. CHIP 1000 5% 20X40

Ref. Des.	Part Number	Description
R528	0662057M74	RES. CHIP 1000 5% 20X40
R531	0662057M64	RES. CHIP 390 5% 20X40
R533	0662057M82	RES. CHIP 2200 5% 20X40
R536	0662057N23	RES. CHIP 100K 5% 20X40
R537	0662057N17	RES. CHIP 56K 5% 20X40
R538	0662057M01	RES. CHIP 0 5% 20X40
R539	0662057M01	RES. CHIP 0 5% 20X40
R540	0662057M95	RES. CHIP 7500 5% 20X40
R545	0662057M98	RES. CHIP 10K 5% 20X40
R548	0662057N06	RES. CHIP 20K 5% 20X40
R549	0662057M98	RES. CHIP 10K 5% 20X40
R550	0662057N17	RES. CHIP 56K 5% 20X40
R551	0662057N06	RES. CHIP 20K 5% 20X40
R553	0662057M98	RES. CHIP 10K 5% 20X40
R554	0662057N17	RES. CHIP 56K 5% 20X40
R555	0662057M74	RES. CHIP 1000 5% 20X40
R556	0662057N06	RES. CHIP 20K 5% 20X40
R557	0662057M98	RES. CHIP 10K 5% 20X40
R558	0662057M94	RES. CHIP 6800 5% 20X40
R559	0662057M98	RES. CHIP 10K 5% 20X40
R560	0662057M01	RES. CHIP 0 5% 20X40
R561	0662057M74	RES. CHIP 1000 5% 20X40
R563	0662057M64	RES. CHIP 390 5% 20X40
R564	0662057M98	RES. CHIP 10K 5% 20X40
R565	0662057M82	RES. CHIP 2200 5% 20X40
R566	0662057M95	RES. CHIP 7500 5% 20X40
R567	0662057N15	RES. CHIP 47K 5% 20X40
R568	0662057N15	RES. CHIP 47K 5% 20X40
R569	0662057M90	RES. CHIP 4700 5% 20X40
R572	0662057M50	RES. CHIP 100 5% 20X40
R573	0662057N23	RES. CHIP 100K 5% 20X40
R574	0662057N23	RES. CHIP 100K 5% 20X40
R575	0662057M98	RES. CHIP 10K 5% 20X40
R576	0662057N23	RES. CHIP 100K 5% 20X40
R577	0662057N15	RES. CHIP 47K 5% 20X40
R578	0662057N15	RES. CHIP 47K 5% 20X40
R579	NOTPLACED	NOT PLACED
R580	NOTPLACED	NOT PLACED
R581	0662057M01	RES. CHIP 0 5% 20X40

Ref. Des.	Part Number	Description
R582	0662057M90	RES. CHIP 4700 5% 20X40
R583	0662057M90	RES. CHIP 4700 5% 20X40
R584	0662057M98	RES. CHIP 10K 5% 20X40
R585	0662057M98	RES. CHIP 10K 5% 20X40
R586	0662057N39	RES. CHIP 470K 5% 20X40
R587	0662057M34	RES. CHIP 22 5% 20X40
R588	0662057M34	RES. CHIP 22 5% 20X40
R589	0662057M98	RES. CHIP 10K 5% 20X40
RESET_OUT	NOTPLACED	NOT PLACED
S101	NOTPLACED	NOT PLACED
SCKA	NOTPLACED	NOT PLACED
SCKB	NOTPLACED	NOT PLACED
TCK	NOTPLACED	NOT PLACED
TDI	NOTPLACED	NOT PLACED
TDO	NOTPLACED	NOT PLACED
TMS	NOTPLACED	NOT PLACED
TP201	NOTPLACED	NOT PLACED
TP202	NOTPLACED	NOT PLACED
TP206	NOTPLACED	NOT PLACED
TP207	NOTPLACED	NOT PLACED
TP208	NOTPLACED	NOT PLACED
TP209	NOTPLACED	NOT PLACED
TP210	NOTPLACED	NOT PLACED
TP211	NOTPLACED	NOT PLACED
TP212	NOTPLACED	NOT PLACED
TP213	NOTPLACED	NOT PLACED
TP214	NOTPLACED	NOT PLACED
TP215	NOTPLACED	NOT PLACED
TRST	NOTPLACED	NOT PLACED
U201	5109731C15	IC OP AMP SNGL OPA237 SOT23
U202	5109731C15	IC OP AMP SNGL OPA237 SOT23
U301	5185353D57	IC FILLPER WITH IMPROVED ESD
U302	5105492X92	IC CMOS BILATERAL SWITCH
U303	5109522E53	IC SNGL BUF NC7S125P5X SC70

Ref. Des.	Part Number	Description
U401	5109841C69	IC 256 BGA 17X17 PACKAGE PATRIOT
U402	5199485A01	IC FLASH 8MBYTE BURST BGA
U403	5185368C82	"IC 1.65 TO 2.2V, 70NS, 8MBIT SRAM"
U404	5109522E53	IC SNGL BUF NC7S125P5X SC70
U405	5109522E53	IC SNGL BUF NC7S125P5X SC70
U406	5105492X03	IC SNG HI SPD L-MOS NOT GATE
U501	5109879E58	IC 4.3 GCAPII SN104616DGGMR BG
U502	5109731C15	IC OP AMP SNGL OPA237 SOT23
U503	5102463J44	IC AUDIO PA (PHILIPS_20PIN)
U504	5109731C15	IC OP AMP SNGL OPA237 SOT23
U505	5185353D13	IC MINI SO-8 HI PRECISION REG 5V
U507	5109731C15	IC OP AMP SNGL OPA237 SOT23
U509	5185353D35	IC DUAL EEPOT 256 TAP
U510	5105492X92	IC CMOS BILATERAL SWITCH
U511	5185353D56	IC 3.3V LINEAR REGULATOR MC78LC 33NTR
VR201	4813832C72	TRANS SUP QUAD 12V
VR202	4813830A22	DIODE 9.1V 5% 225MW MMBZ5239B_
VR203	4813832C72	TRANS SUP QUAD 12V
VR204	4813830C26	DIODE 13V 'H3' MMSZ5243BT1
VR205	4805656W08	DIODE ZENER QUAD
VR206	4805656W08	DIODE ZENER QUAD
VR209	4813832C72	TRANS SUP QUAD 12V
VR220	4805656W03	DIODE DUAL 5.6V ZENER
VR221	4805656W03	DIODE DUAL 5.6V ZENER
VR501	4813830A15	DIODE 5.6V 5% 225MW MMBZ5232B_
W203	4805723X03	TRANS DUAL NPN-PNP UMD3N ROHM

Ref. Des.	Part Number	Description
WAIT	NOTPLACED	NOT PLACED
Y301	4809995L05	XTAL QUARTZ 32.768 kHz CC4V-T1

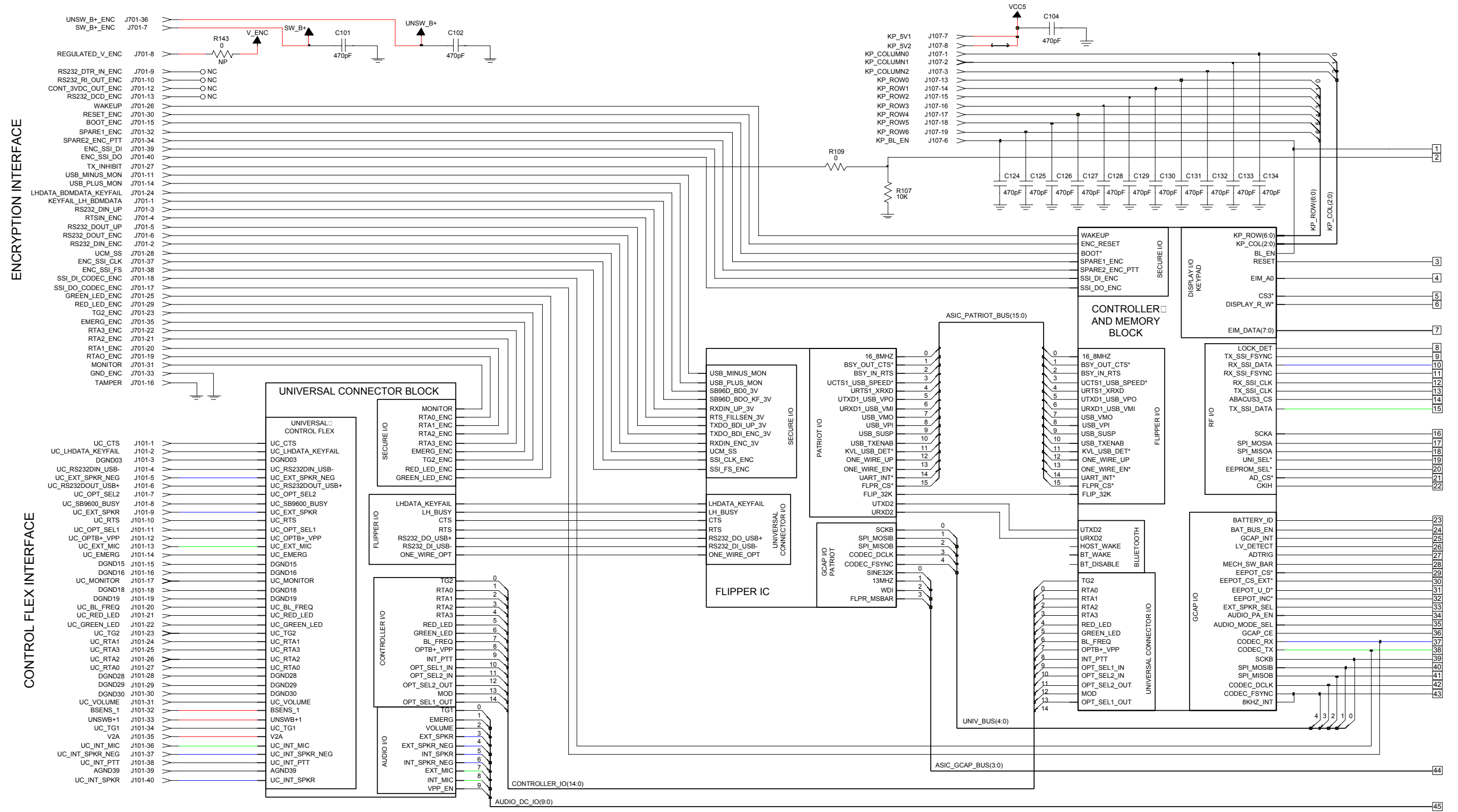

Figure 8-70. NTN9564C VOCON Board Overall Schematic—1 of 2

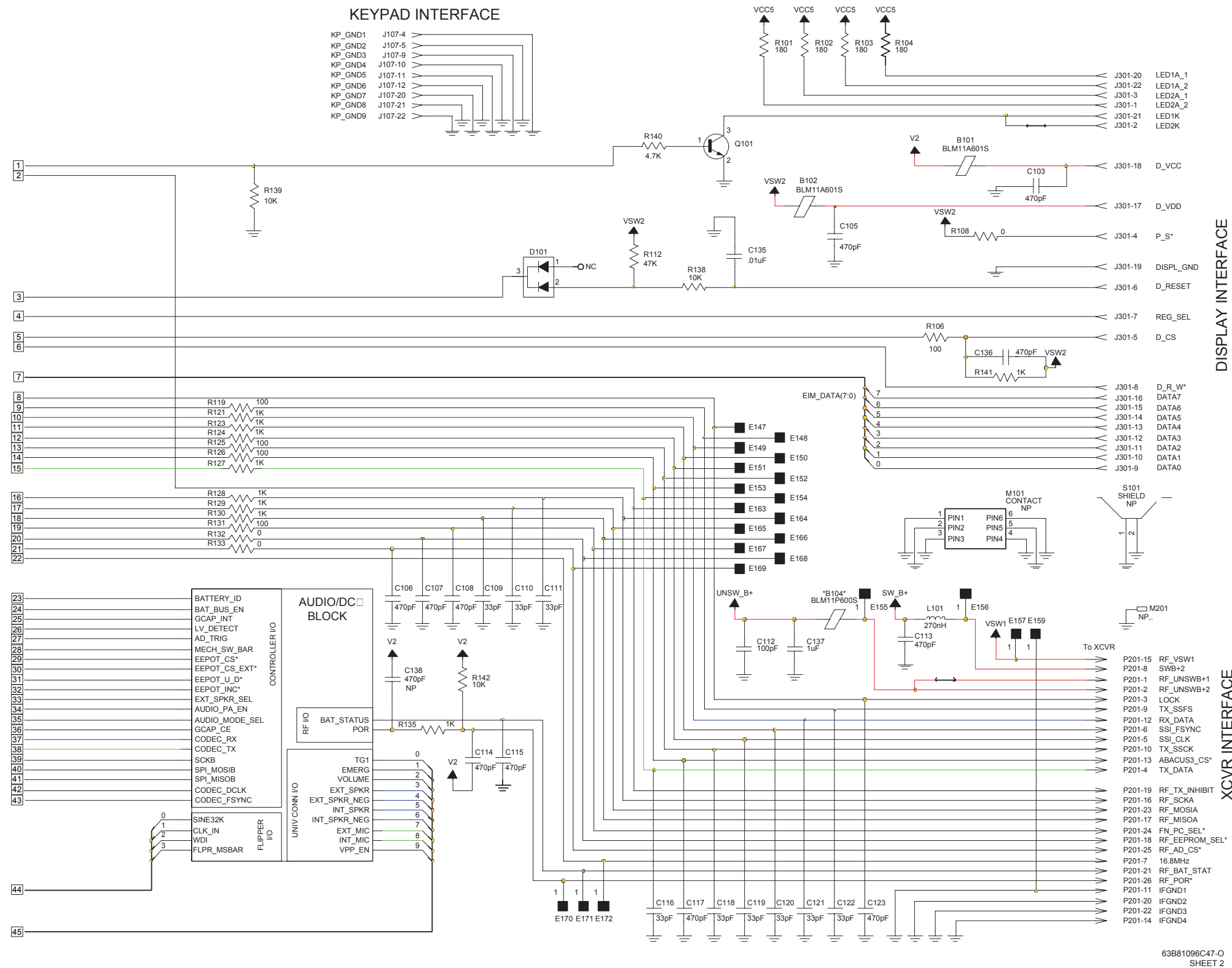
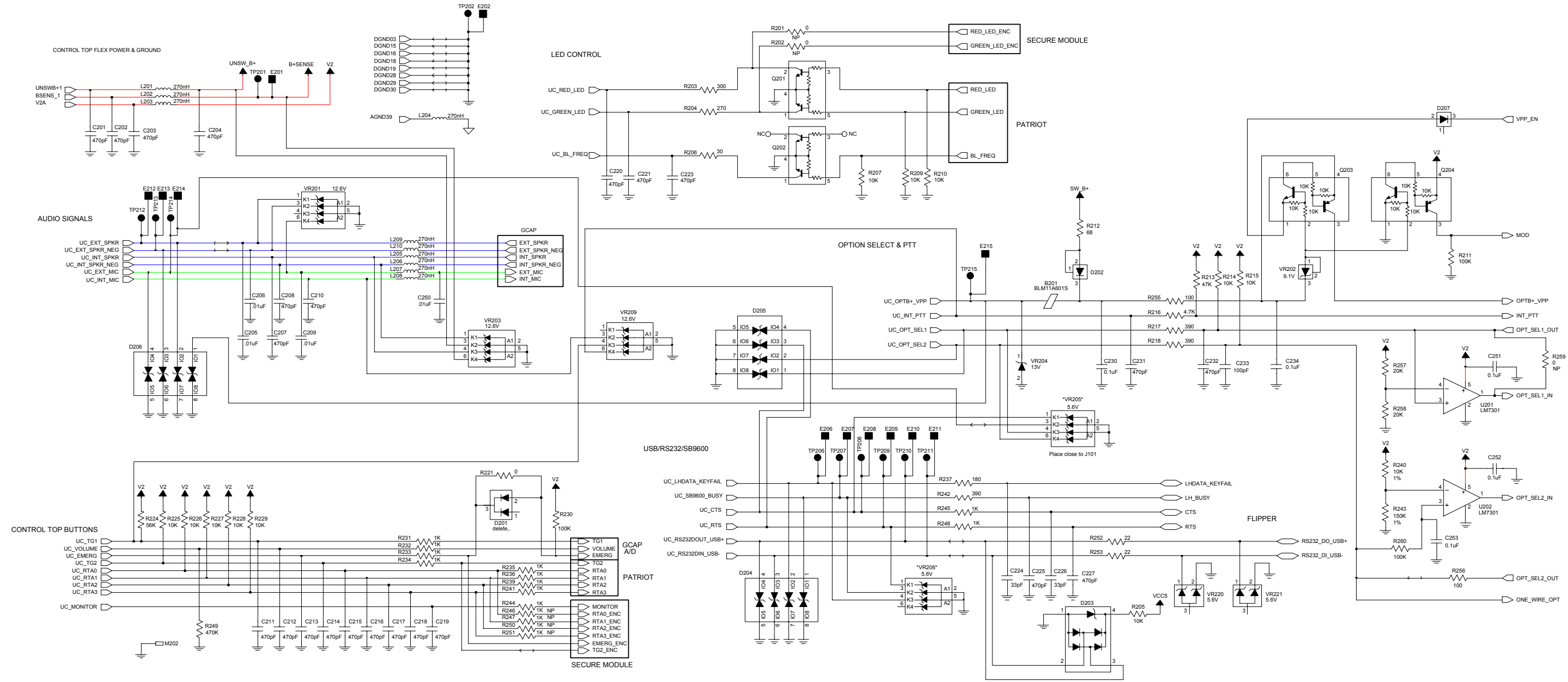

Figure 8-71. NTN9564C VOCON Board Overall Schematic—2 of 2



63B81096C50-O

Figure 8-72. NTN9564C VOCON Universal Connector Circuit

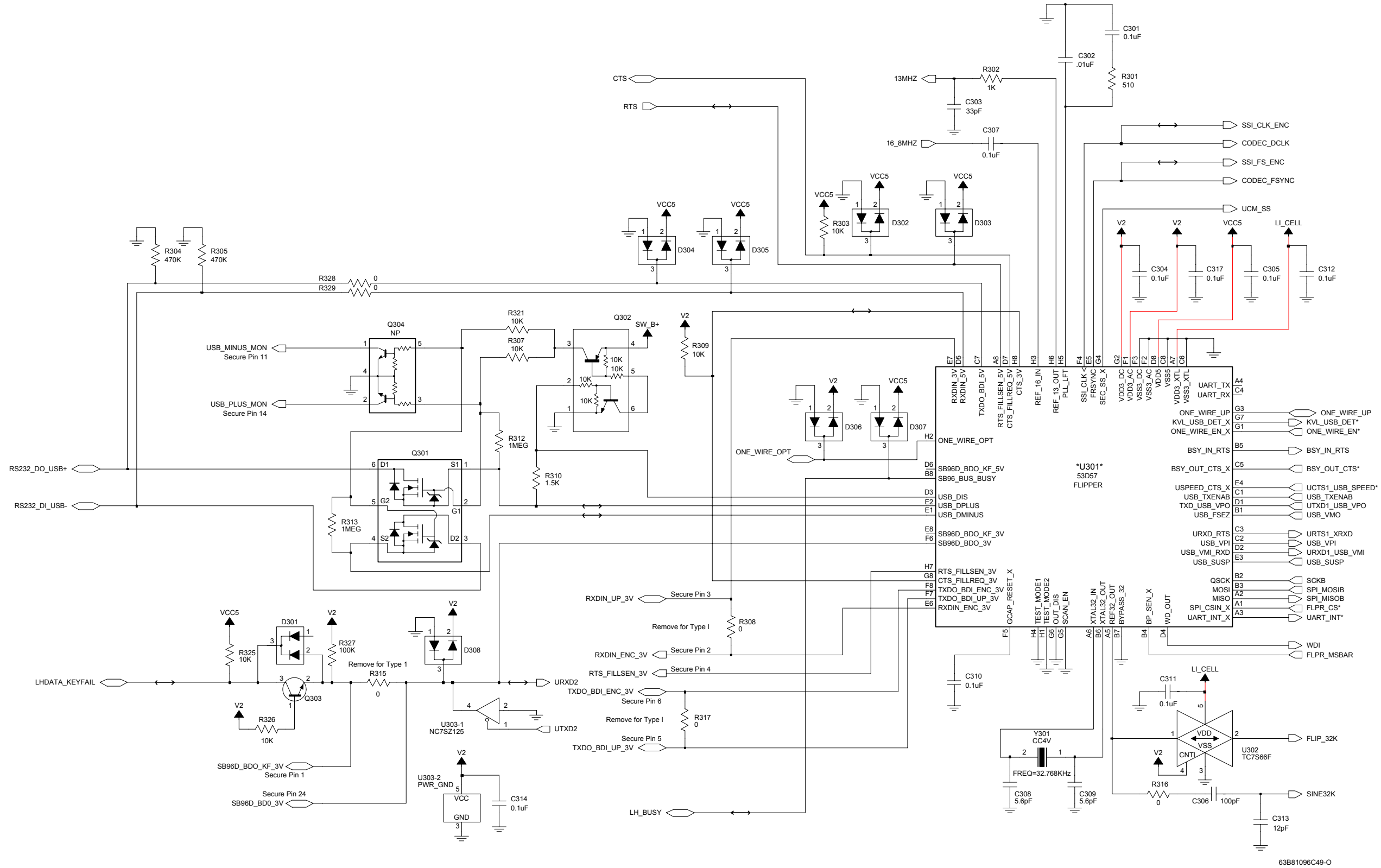

Figure 8-73. NTN9564C VOCON Flipper Circuit



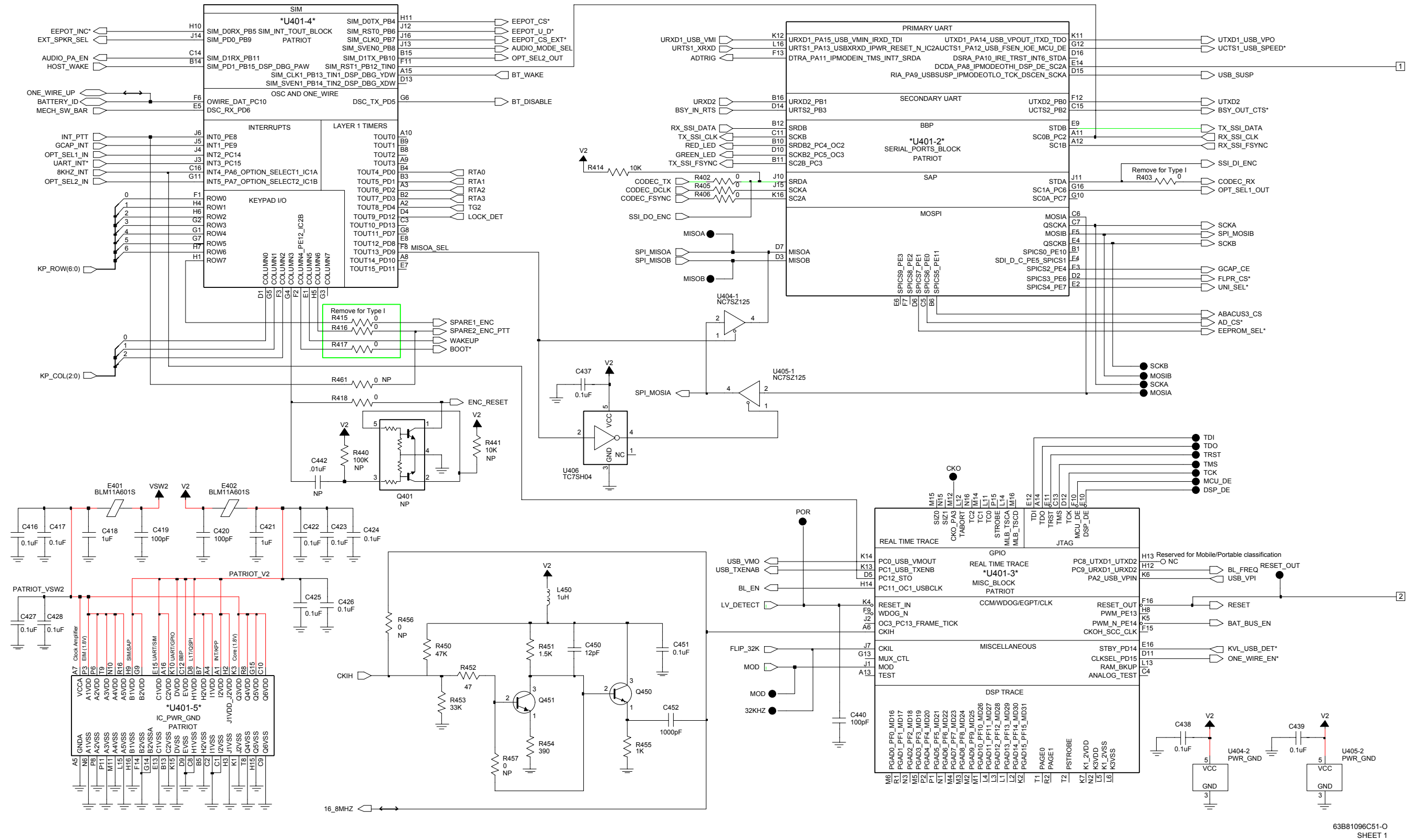
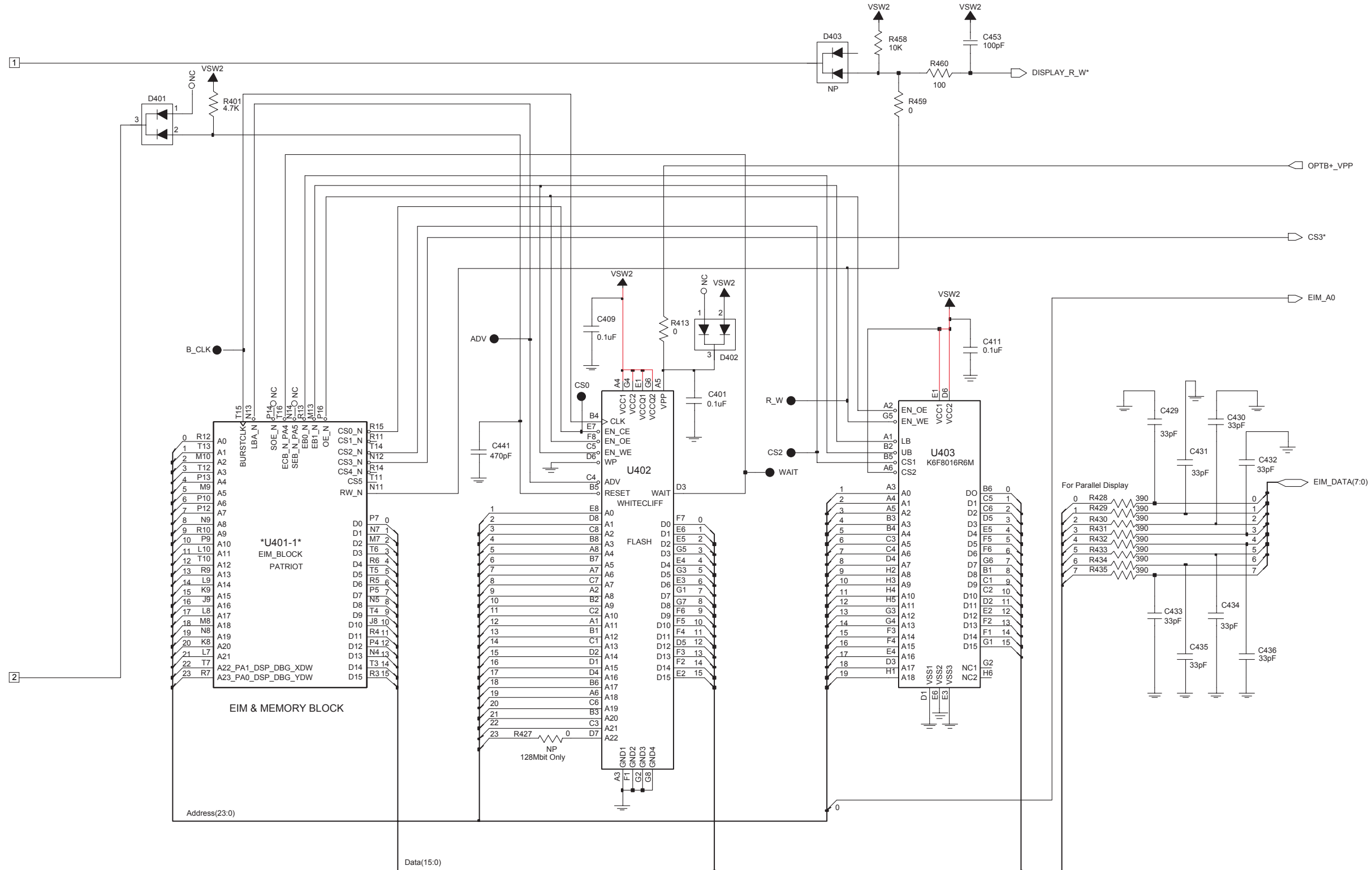

Figure 8-74. NTN9564C VOCON Controller and Memory Circuits—1 of 2





63B81096C51-0  
SHEET 2

Figure 8-75. NTN9564C VOCON Controller and Memory Circuits—2 of 2

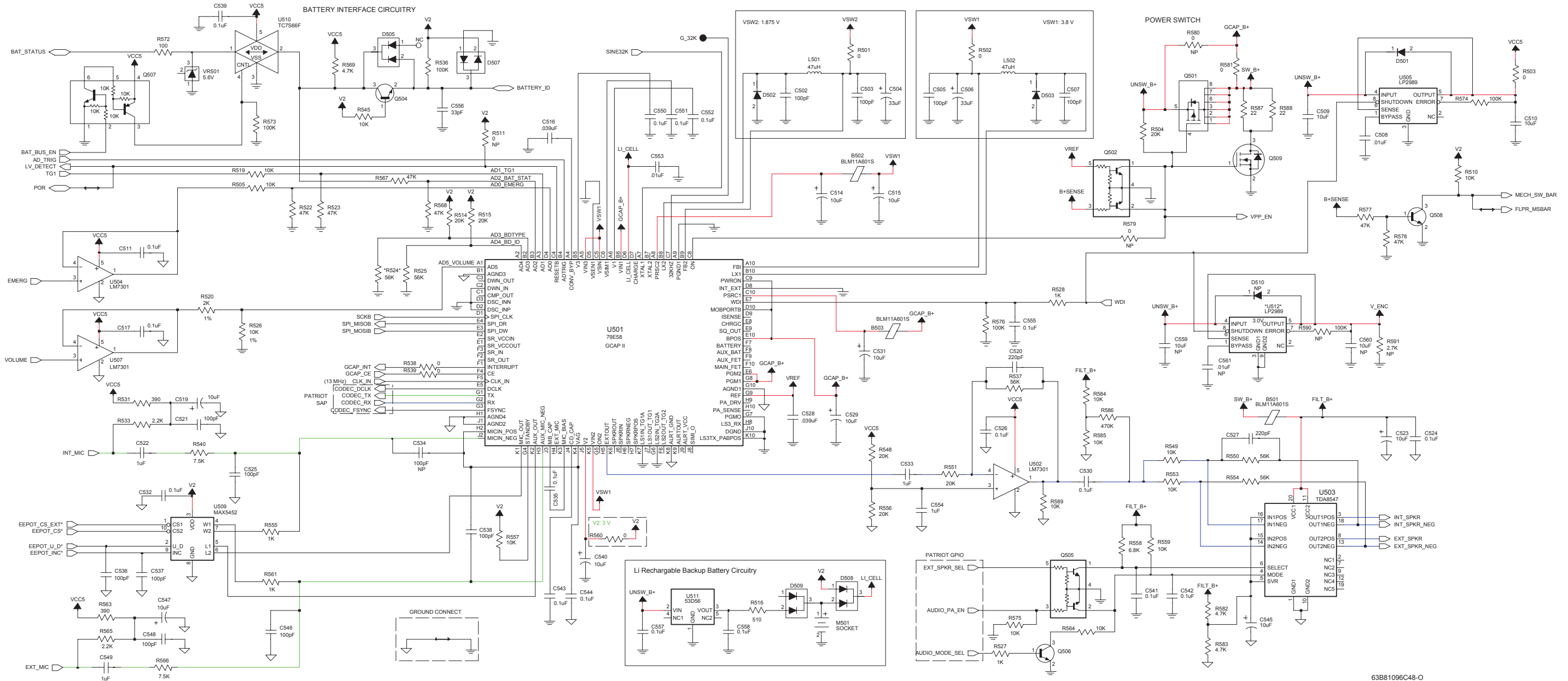

63B81096C48-O

Figure 8-76. NTN9564C VOCON Audio and DC Circuits

VIEWED FROM SIDE 1

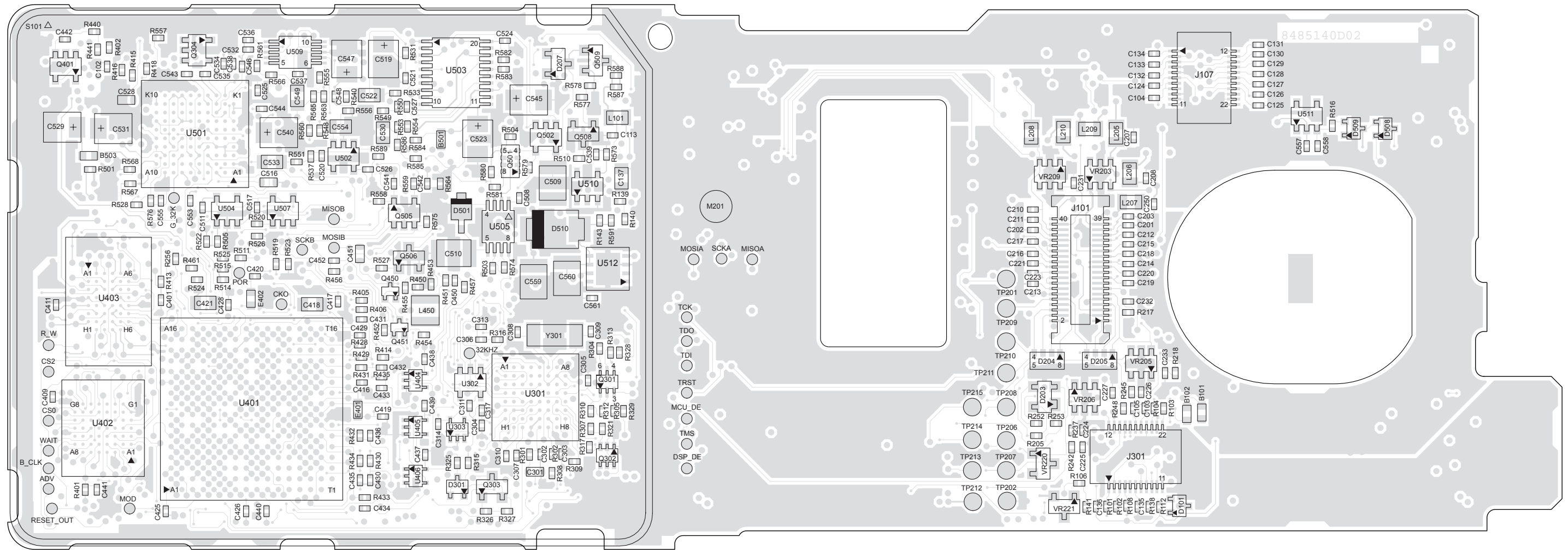

MAEPF-27521-O

Figure 8-77. NTN9564C VOCON Board Layout—Side 1

VIEWED FROM SIDE 2

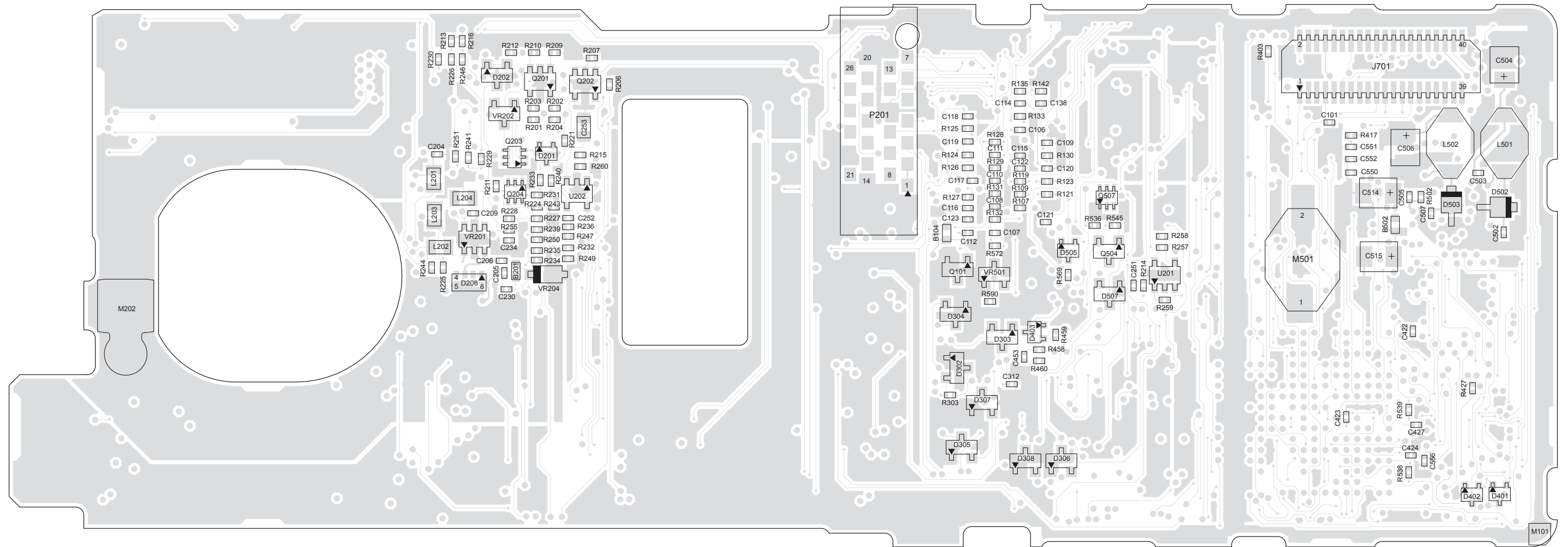

MAEPF-27522-O

Figure 8-78. NTN9564C VOCON Board Layout—Side 2

## NTN9564C VOCON Board Parts List

Ref. Des.	Part Number	Description
—	6003710K08	BATT COIN 3.3V LIION
32KHZ	NOTPLACED	NOTPLACED
ADV	NOTPLACED	NOTPLACED
B_CLK	NOTPLACED	NOTPLACED
B101	2480574F01	IND FERRITE CHIP 600 OHM 0603
B102	2480574F01	IND FERRITE CHIP 600 OHM 0603
B104	2462586G33	INDUCTOR CHIP FERRITE BEADS
B201	2480574F01	IND FERRITE CHIP 600 OHM 0603
B501	2480574F01	IND FERRITE CHIP 600 OHM 0603
B502	2480574F01	IND FERRITE CHIP 600 OHM 0603
B503	2480574F01	IND FERRITE CHIP 600 OHM 0603
C101	2113743L09	CAP CHIP 470 PF 10% X7R
C102	2113743L09	CAP CHIP 470 PF 10% X7R
C103	2113743L09	CAP CHIP 470 PF 10% X7R
C104	2113743L09	CAP CHIP 470 PF 10% X7R
C105	2113743L09	CAP CHIP 470 PF 10% X7R
C106	2113743L09	CAP CHIP 470 PF 10% X7R
C107	2113743L09	CAP CHIP 470 PF 10% X7R
C108	2113743L09	CAP CHIP 470 PF 10% X7R
C109	2113743N38	CAP CHIP 33.0 PF 5% COG
C110	2113743N38	CAP CHIP 33.0 PF 5% COG
C111	2113743N38	CAP CHIP 33.0 PF 5% COG
C112	2113743N50	CAP CHIP 100 PF 5% COG
C113	2113743L09	CAP CHIP 470 PF 10% X7R
C114	2113743L09	CAP CHIP 470 PF 10% X7R
C115	2113743L09	CAP CHIP 470 PF 10% X7R
C116	2113743N38	CAP CHIP 33.0 PF 5% COG
C117	2113743L09	CAP CHIP 470 PF 10% X7R
C118	2113743N38	CAP CHIP 33.0 PF 5% COG

Ref. Des.	Part Number	Description
C119	2113743N38	CAP CHIP 33.0 PF 5% COG
C120	2113743N38	CAP CHIP 33.0 PF 5% COG
C121	2113743N38	CAP CHIP 33.0 PF 5% COG
C122	2113743N38	CAP CHIP 33.0 PF 5% COG
C123	2113743L09	CAP CHIP 470 PF 10% X7R
C124	2113743L09	CAP CHIP 470 PF 10% X7R
C125	2113743L09	CAP CHIP 470 PF 10% X7R
C126	2113743L09	CAP CHIP 470 PF 10% X7R
C127	2113743L09	CAP CHIP 470 PF 10% X7R
C128	2113743L09	CAP CHIP 470 PF 10% X7R
C129	2113743L09	CAP CHIP 470 PF 10% X7R
C130	2113743L09	CAP CHIP 470 PF 10% X7R
C131	2113743L09	CAP CHIP 470 PF 10% X7R
C132	2113743L09	CAP CHIP 470 PF 10% X7R
C133	2113743L09	CAP CHIP 470 PF 10% X7R
C134	2113743L09	CAP CHIP 470 PF 10% X7R
C135	2113743L41	CAP CHIP 10000 PF 10% X7R
C136	2113743L09	CAP CHIP 470 PF 10% X7R
C137	2113743A31	CAP CHIP 1.0UF 10% X7R
C138	NOTPLACED	NOTPLACED
C201	2113743L09	CAP CHIP 470 PF 10% X7R
C202	2113743L09	CAP CHIP 470 PF 10% X7R
C203	2113743L09	CAP CHIP 470 PF 10% X7R
C204	2113743L09	CAP CHIP 470 PF 10% X7R
C205	2113743L41	CAP CHIP 10000 PF 10% X7R
C206	2113743L41	CAP CHIP 10000 PF 10% X7R
C207	2113743L09	CAP CHIP 470 PF 10% X7R
C208	2113743L09	CAP CHIP 470 PF 10% X7R
C209	2113743L41	CAP CHIP 10000 PF 10% X7R
C210	2113743L09	CAP CHIP 470 PF 10% X7R
C211	2113743L09	CAP CHIP 470 PF 10% X7R
C212	2113743L09	CAP CHIP 470 PF 10% X7R

Ref. Des.	Part Number	Description
C213	2113743L09	CAP CHIP 470 PF 10% X7R
C214	2113743L09	CAP CHIP 470 PF 10% X7R
C215	2113743L09	CAP CHIP 470 PF 10% X7R
C216	2113743L09	CAP CHIP 470 PF 10% X7R
C217	2113743L09	CAP CHIP 470 PF 10% X7R
C218	2113743L09	CAP CHIP 470 PF 10% X7R
C219	2113743L09	CAP CHIP 470 PF 10% X7R
C220	2113743L09	CAP CHIP 470 PF 10% X7R
C221	2113743L09	CAP CHIP 470 PF 10% X7R
C223	2113743L09	CAP CHIP 470 PF 10% X7R
C224	2113743N38	CAP CHIP 33.0 PF 5% COG
C225	2113743L09	CAP CHIP 470 PF 10% X7R
C226	2113743N38	CAP CHIP 33.0 PF 5% COG
C227	2113743L09	CAP CHIP 470 PF 10% X7R
C230	2113743M24	CAP CHIP 100000 PF +80-20% Y5V
C231	2113743L09	CAP CHIP 470 PF 10% X7R
C232	2113743L09	CAP CHIP 470 PF 10% X7R
C233	2113743N50	CAP CHIP 100 PF 5% COG
C234	2113743M24	CAP CHIP 100000 PF +80-20% Y5V
C250	2113743L41	CAP CHIP 10000 PF 10% X7R
C251	2113743M24	CAP CHIP 100000 PF +80-20% Y5V
C252	2113743M24	CAP CHIP 100000 PF +80-20% Y5V
C253	2113743A19	CAP CHIP .100 UF 10% X7R
C301	2113932E20	CAP CER CHP .10 UF 10% 16V
C302	2113743L41	CAP CHIP 10000 PF 10% X7R
C303	2113743N38	CAP CHIP 33.0 PF 5% COG
C304	2113743M24	CAP CHIP 100000 PF +80-20% Y5V
C305	2113743M24	CAP CHIP 100000 PF +80-20% Y5V

Ref. Des.	Part Number	Description
C306	2113743N50	CAP CHIP 100 PF 5% COG
C307	2113743M24	CAP CHIP 100000 PF +80-20% Y5V
C308	2113743N20	CAP CHIP 5.6PF +/-5PF COG
C309	2113743N20	CAP CHIP 5.6PF +/-5PF COG
C310	2113743M24	CAP CHIP 100000 PF +80-20% Y5V
C311	2113743M24	CAP CHIP 100000 PF +80-20% Y5V
C312	2113743M24	CAP CHIP 100000 PF +80-20% Y5V
C313	2113743N28	CAP CHIP 12.0 PF 5% COG
C314	2113743M24	CAP CHIP 100000 PF +80-20% Y5V
C317	2113743M24	CAP CHIP 100000 PF +80-20% Y5V
C401	2113743M24	CAP CHIP 100000 PF +80-20% Y5V
C409	2113743M24	CAP CHIP 100000 PF +80-20% Y5V
C411	2113743M24	CAP CHIP 100000 PF +80-20% Y5V
C416	2113743M24	CAP CHIP 100000 PF +80-20% Y5V
C417	2113743M24	CAP CHIP 100000 PF +80-20% Y5V
C418	2113743A31	CAP CHIP 1.0UF 10% X7R
C419	2113743N50	CAP CHIP 100 PF 5% COG
C420	2113743N50	CAP CHIP 100 PF 5% COG
C421	2113743A31	CAP CHIP 1.0UF 10% X7R
C422	2113743M24	CAP CHIP 100000 PF +80-20% Y5V
C423	2113743M24	CAP CHIP 100000 PF +80-20% Y5V
C424	2113743M24	CAP CHIP 100000 PF +80-20% Y5V
C425	2113743M24	CAP CHIP 100000 PF +80-20% Y5V

Ref. Des.	Part Number	Description
C426	2113743M24	CAP CHIP 100000 PF +80-20% Y5V
C427	2113743M24	CAP CHIP 100000 PF +80-20% Y5V
C428	2113743M24	CAP CHIP 100000 PF +80-20% Y5V
C429	2113743N38	CAP CHIP 33.0 PF 5% COG
C430	2113743N38	CAP CHIP 33.0 PF 5% COG
C431	2113743N38	CAP CHIP 33.0 PF 5% COG
C432	2113743N38	CAP CHIP 33.0 PF 5% COG
C433	2113743N38	CAP CHIP 33.0 PF 5% COG
C434	2113743N38	CAP CHIP 33.0 PF 5% COG
C435	2113743N38	CAP CHIP 33.0 PF 5% COG
C436	2113743N38	CAP CHIP 33.0 PF 5% COG
C437	2113743M24	CAP CHIP 100000 PF +80-20% Y5V
C438	2113743M24	CAP CHIP 100000 PF +80-20% Y5V
C439	2113743M24	CAP CHIP 100000 PF +80-20% Y5V
C440	2113743N50	CAP CHIP 100 PF 5% COG
C441	2113743L09	CAP CHIP 470 PF 10% X7R
C442	NOTPLACED	NOTPLACED
C450	2113743N28	CAP CHIP 12.0 PF 5% COG
C451	2113932E20	CAP CER CHP .10 UF 10% 16V
C452	2113743L17	CAP CHIP 1000 PF 10% X7R
C453	2113743N50	CAP CHIP 100 PF 5% COG
C502	2113743N50	CAP CHIP 100 PF 5% COG
C503	2113743N50	CAP CHIP 100 PF 5% COG
C504	2311049C52	CAP TANT CHIP 33UF 10% 10V
C505	2113743N50	CAP CHIP 100 PF 5% COG
C506	2311049C52	CAP TANT CHIP 33UF 10% 10V
C507	2113743N50	CAP CHIP 100 PF 5% COG
C508	2113743L41	CAP CHIP 10000 PF 10% X7R

Ref. Des.	Part Number	Description
C509	2113743T19	CAP 10UF 16V CER 3225 X5R
C510	2113743T19	CAP 10UF 16V CER 3225 X5R
C511	2113743M24	CAP CHIP 100000 PF +80-20% Y5V
C514	2311049A57	CAP TANT CHIP A/P 10UF 10% 16V
C515	2311049A57	CAP TANT CHIP A/P 10UF 10% 16V
C516	2113743E11	CAP CHIP .039 UF 10% X7R
C517	2113743M24	CAP CHIP 100000 PF +80-20% Y5V
C519	2311049A57	CAP TANT CHIP A/P 10UF 10% 16V
C520	2113743L01	CAP CHIP 220 PF 10% X7R
C521	2113743N50	CAP CHIP 100 PF 5% COG
C522	2113743A31	CAP CHIP 1.0UF 10% X7R
C523	2311049A57	CAP TANT CHIP A/P 10UF 10% 16V
C524	2113743M24	CAP CHIP 100000 PF +80-20% Y5V
C525	2113743N50	CAP CHIP 100 PF 5% COG
C526	2113743M24	CAP CHIP 100000 PF +80-20% Y5V
C527	2113743L01	CAP CHIP 220 PF 10% X7R
C528	2113743E11	CAP CHIP .039 UF 10% X7R
C529	2311049A57	CAP TANT CHIP A/P 10UF 10% 16V
C530	2113743A19	CAP CHIP .100 UF 10% X7R
C531	2311049A57	CAP TANT CHIP A/P 10UF 10% 16V
C532	2113743M24	CAP CHIP 100000 PF +80-20% Y5V
C533	2113743A31	CAP CHIP 1.0UF 10% X7R
C534	NOTPLACED	NOTPLACED
C535	2113743M24	CAP CHIP 100000 PF +80-20% Y5V

Ref. Des.	Part Number	Description
C536	2113743N50	CAP CHIP 100 PF 5% COG
C537	2113743N50	CAP CHIP 100 PF 5% COG
C538	2113743N50	CAP CHIP 100 PF 5% COG
C539	2113743M24	CAP CHIP 100000 PF +80-20% Y5V
C540	2311049A57	CAP TANT CHIP A/P 10UF 10% 16V
C541	2113743M24	CAP CHIP 100000 PF +80-20% Y5V
C542	2113743M24	CAP CHIP 100000 PF +80-20% Y5V
C543	2113743M24	CAP CHIP 100000 PF +80-20% Y5V
C544	2113743M24	CAP CHIP 100000 PF +80-20% Y5V
C545	2311049A57	CAP TANT CHIP A/P 10UF 10% 16V
C546	2113743N50	CAP CHIP 100 PF 5% COG
C547	2311049A57	CAP TANT CHIP A/P 10UF 10% 16V
C548	2113743N50	CAP CHIP 100 PF 5% COG
C549	2113743A31	CAP CHIP 1.0UF 10% X7R
C550	2113743M24	CAP CHIP 100000 PF +80-20% Y5V
C551	2113743M24	CAP CHIP 100000 PF +80-20% Y5V
C552	2113743M24	CAP CHIP 100000 PF +80-20% Y5V
C553	2113743L41	CAP CHIP 10000 PF 10% X7R
C554	2113743A31	CAP CHIP 1.0UF 10% X7R
C555	2113743M24	CAP CHIP 100000 PF +80-20% Y5V
C556	2113743N38	CAP CHIP 33.0 PF 5% COG
C557	2113743M24	CAP CHIP 100000 PF +80-20% Y5V
C558	2113743M24	CAP CHIP 100000 PF +80-20% Y5V
C559	NOTPLACED	NOTPLACED
C560	NOTPLACED	NOTPLACED

Ref. Des.	Part Number	Description
C561	NOTPLACED	NOTPLACED
CKO	NOTPLACED	NOTPLACED
CS0	NOTPLACED	NOTPLACED
CS2	NOTPLACED	NOTPLACED
D101	4805218N57	DIODE DUAL
D201	NOTPLACED	NOTPLACED
D202	4805129M90	DIODE SOT PKGD
D203	4802021P15	ZENER SR05
D204	4805656W39	QUAD ESD SUPPRESSOR ARRAY -41206ESDA
D205	4805656W39	QUAD ESD SUPPRESSOR ARRAY -41206ESDA
D206	4805656W39	QUAD ESD SUPPRESSOR ARRAY -41206ESDA
D207	4805129M90	DIODE SOT PKGD
D301	4805218N57	DIODE DUAL
D302	4805129M06	DIODE MMBD7000
D303	4805129M06	DIODE MMBD7000
D304	4805129M06	DIODE MMBD7000
D305	4805129M06	DIODE MMBD7000
D306	4805129M06	DIODE MMBD7000
D307	4805129M06	DIODE MMBD7000
D308	4805129M06	DIODE MMBD7000
D401	4805218N57	DIODE DUAL
D402	4805218N57	DIODE DUAL
D403	NOTPLACED	NOTPLACED
D501	4813833A20	DIODE SCHOTTKY 1A 40V PWRMITE
D502	4813833A20	DIODE SCHOTTKY 1A 40V PWRMITE
D503	4813833A20	DIODE SCHOTTKY 1A 40V PWRMITE
D505	4805218N57	DIODE DUAL
D507	4805129M06	DIODE MMBD7000
D508	4805218N57	DIODE DUAL
D509	4805218N57	DIODE DUAL
D510	NOTPLACED	NOTPLACED



Ref. Des.	Part Number	Description
DSP_DE	NOTPLACED	NOTPLACED
E147	NOTPLACED	NOTPLACED
E148	NOTPLACED	NOTPLACED
E149	NOTPLACED	NOTPLACED
E150	NOTPLACED	NOTPLACED
E151	NOTPLACED	NOTPLACED
E152	NOTPLACED	NOTPLACED
E153	NOTPLACED	NOTPLACED
E154	NOTPLACED	NOTPLACED
E155	NOTPLACED	NOTPLACED
E156	NOTPLACED	NOTPLACED
E157	NOTPLACED	NOTPLACED
E159	NOTPLACED	NOTPLACED
E163	NOTPLACED	NOTPLACED
E164	NOTPLACED	NOTPLACED
E165	NOTPLACED	NOTPLACED
E166	NOTPLACED	NOTPLACED
E167	NOTPLACED	NOTPLACED
E168	NOTPLACED	NOTPLACED
E169	NOTPLACED	NOTPLACED
E170	NOTPLACED	NOTPLACED
E171	NOTPLACED	NOTPLACED
E172	NOTPLACED	NOTPLACED
E201	NOTPLACED	NOTPLACED
E202	NOTPLACED	NOTPLACED
E206	NOTPLACED	NOTPLACED
E207	NOTPLACED	NOTPLACED
E208	NOTPLACED	NOTPLACED
E209	NOTPLACED	NOTPLACED
E210	NOTPLACED	NOTPLACED
E211	NOTPLACED	NOTPLACED
E212	NOTPLACED	NOTPLACED
E213	NOTPLACED	NOTPLACED
E214	NOTPLACED	NOTPLACED

Ref. Des.	Part Number	Description
E215	NOTPLACED	NOTPLACED
E401	2480574F01	IND FERRITE CHIP 600 OHM 0603
E402	2480574F01	IND FERRITE CHIP 600 OHM 0603
G_32K	NOTPLACED	NOTPLACED
J101	0985185D01	CONN RECEP 0.5MM PITCH 40 CKTS
J107	0987817K01	RECP BTB 0.5P 1.5 STACK SMD
J301	0987817K01	RECP BTB 0.5P 1.5 STACK SMD
J701	0980423L02	40PIN ROBIN CONN 3MM
L101	2404574Z14	IND CHIP WW 270NH 2% 2012 SMD
L201	2404574Z14	IND CHIP WW 270NH 2% 2012 SMD
L202	2404574Z14	IND CHIP WW 270NH 2% 2012 SMD
L203	2404574Z14	IND CHIP WW 270NH 2% 2012 SMD
L204	2404574Z14	IND CHIP WW 270NH 2% 2012 SMD
L205	2404574Z14	IND CHIP WW 270NH 2% 2012 SMD
L206	2404574Z14	IND CHIP WW 270NH 2% 2012 SMD
L207	2404574Z14	IND CHIP WW 270NH 2% 2012 SMD
L208	2404574Z14	IND CHIP WW 270NH 2% 2012 SMD
L209	2404574Z14	IND CHIP WW 270NH 2% 2012 SMD
L210	2404574Z14	IND CHIP WW 270NH 2% 2012 SMD
L450	2462587N68	CHIP IND 1000 NH 5%
L501	2486085A06	COIL 47UH SMT POWER INDUCTOR
L502	2486085A06	COIL 47UH SMT POWER INDUCTOR
M101	NOTPLACED	NOTPLACED

Ref. Des.	Part Number	Description
M201	NOTPLACED	NOTPLACED
M202	3985951A01	CONTACT ANTENNA GROUND
M501	0985888K02	SKT RTC BTTY LEAP
MCU_DE	NOTPLACED	NOTPLACED
MISOA	NOTPLACED	NOTPLACED
MISOB	NOTPLACED	NOTPLACED
MOD	NOTPLACED	NOTPLACED
MOSIA	NOTPLACED	NOTPLACED
MOSIB	NOTPLACED	NOTPLACED
P201	NOTPLACED	NOTPLACED
PCB	8485140D02	PCB MAIN
POR	NOTPLACED	NOTPLACED
Q101	4813824A10	TSTR NPN 40V .2A GEN PURP
Q201	4805921T09	XSTR DUAL ROHM FMG8
Q202	4805921T09	XSTR DUAL ROHM FMG8
Q203	4805723X03	TRANS DUAL NPN-PNP UMD3N ROHM
Q204	4805723X03	TRANS DUAL NPN-PNP UMD3N ROHM
Q301	4809579E35	TSTR FET DUAL N-CHAN FDG3601N
Q302	4805723X03	TRANS DUAL NPN-PNP UMD3N ROHM
Q303	4813824A10	TSTR NPN 40V .2A GEN PURP
Q304	NOTPLACED	NOTPLACED
Q401	NOTPLACED	NOTPLACED
Q450	4805793Y01	TRANS MINI SOT NPN LOW NOISE
Q451	4805793Y01	TRANS MINI SOT NPN LOW NOISE
Q501	4885844C01	XSTR FET
Q502	4805921T09	XSTR DUAL ROHM FMG8
Q504	4813824A10	TSTR NPN 40V .2A GEN PURP
Q505	4805921T09	XSTR DUAL ROHM FMG8

Ref. Des.	Part Number	Description
Q506	4813824A10	TSTR NPN 40V .2A GEN PURP
Q507	4805723X03	TRANS DUAL NPN-PNP UMD3N ROHM
Q508	4813824A10	TSTR NPN 40V .2A GEN PURP
Q509	4805218N11	XISTOR SOT RH BST82
R_W	NOTPLACED	NOTPLACED
R101	0662057M56	RES. CHIP 180 5% 20X40
R102	0662057M56	RES. CHIP 180 5% 20X40
R103	0662057M56	RES. CHIP 180 5% 20X40
R104	0662057M56	RES. CHIP 180 5% 20X40
R106	0662057M50	RES. CHIP 100 5% 20X40
R107	0662057M98	RES. CHIP 10K 5% 20X40
R108	0662057M01	RES. CHIP 0 5% 20X40
R109	0662057M01	RES. CHIP 0 5% 20X40
R112	0662057N15	RES. CHIP 47K 5% 20X40
R119	0662057M50	RES. CHIP 100 5% 20X40
R121	0662057M74	RES. CHIP 1000 5% 20X40
R123	0662057M74	RES. CHIP 1000 5% 20X40
R124	0662057M74	RES. CHIP 1000 5% 20X40
R125	0662057M50	RES. CHIP 100 5% 20X40
R126	0662057M50	RES. CHIP 100 5% 20X40
R127	0662057M74	RES. CHIP 1000 5% 20X40
R128	0662057M74	RES. CHIP 1000 5% 20X40
R129	0662057M74	RES. CHIP 1000 5% 20X40
R130	0662057M74	RES. CHIP 1000 5% 20X40
R131	0662057M50	RES. CHIP 100 5% 20X40
R132	0662057M01	RES. CHIP 0 5% 20X40
R133	0662057M01	RES. CHIP 0 5% 20X40
R135	0662057M74	RES. CHIP 1000 5% 20X40
R138	0662057M98	RES. CHIP 10K 5% 20X40
R139	0662057M98	RES. CHIP 10K 5% 20X40
R140	0662057M90	RES. CHIP 4700 5% 20X40
R141	0662057M74	RES. CHIP 1000 5% 20X40
R142	0662057M98	RES. CHIP 10K 5% 20X40

Ref. Des.	Part Number	Description
R143	NOTPLACED	NOTPLACED
R201	NOTPLACED	NOTPLACED
R202	NOTPLACED	NOTPLACED
R203	0662057M61	RES. CHIP 300 5% 20X40
R204	0662057M60	RES. CHIP 270 5% 20X40
R205	0662057M98	RES. CHIP 10K 5% 20X40
R206	0662057M37	20X40 30 OMH 5% CHIP RESISTOR
R207	0662057M98	RES. CHIP 10K 5% 20X40
R209	0662057M98	RES. CHIP 10K 5% 20X40
R210	0662057M98	RES. CHIP 10K 5% 20X40
R211	0662057N23	RES. CHIP 100K 5% 20X40
R212	0662057M46	RES. CHIP 68 5% 20X40
R213	0662057N15	RES. CHIP 47K 5% 20X40
R214	0662057M98	RES. CHIP 10K 5% 20X40
R215	0662057M98	RES. CHIP 10K 5% 20X40
R216	0662057M90	RES. CHIP 4700 5% 20X40
R217	0662057M64	RES. CHIP 390 5% 20X40
R218	0662057M64	RES. CHIP 390 5% 20X40
R221	0662057M01	RES. CHIP 0 5% 20X40
R224	0662057N17	RES. CHIP 56K 5% 20X40
R225	0662057M98	RES. CHIP 10K 5% 20X40
R226	0662057M98	RES. CHIP 10K 5% 20X40
R227	0662057M98	RES. CHIP 10K 5% 20X40
R228	0662057M98	RES. CHIP 10K 5% 20X40
R229	0662057M98	RES. CHIP 10K 5% 20X40
R230	0662057N23	RES. CHIP 100K 5% 20X40
R231	0662057M74	RES. CHIP 1000 5% 20X40
R232	0662057M74	RES. CHIP 1000 5% 20X40
R233	0662057M74	RES. CHIP 1000 5% 20X40
R234	0662057M74	RES. CHIP 1000 5% 20X40
R235	0662057M74	RES. CHIP 1000 5% 20X40
R236	0662057M74	RES. CHIP 1000 5% 20X40
R237	0662057M56	RES. CHIP 180 5% 20X40
R239	0662057M74	RES. CHIP 1000 5% 20X40

Ref. Des.	Part Number	Description
R240	0662057V02	RES CHIP 10K 1% 1/16W
R241	0662057M74	RES. CHIP 1000 5% 20X40
R242	0662057M64	RES. CHIP 390 5% 20X40
R243	0662057V32	RESISTOR, 150 KOHM, 20X40, 1%
R244	0662057M74	RES. CHIP 1000 5% 20X40
R245	0662057M74	RES. CHIP 1000 5% 20X40
R246	NOTPLACED	NOTPLACED
R247	NOTPLACED	NOTPLACED
R248	0662057M74	RES. CHIP 1000 5% 20X40
R249	0662057N39	RES. CHIP 470K 5% 20X40
R250	NOTPLACED	NOTPLACED
R251	NOTPLACED	NOTPLACED
R252	0662057M34	RES. CHIP 22 5% 20X40
R253	0662057M34	RES. CHIP 22 5% 20X40
R255	0662057M50	RES. CHIP 100 5% 20X40
R256	0662057M50	RES. CHIP 100 5% 20X40
R257	0662057N06	RES. CHIP 20K 5% 20X40
R258	0662057N06	RES. CHIP 20K 5% 20X40
R259	NOTPLACED	NOTPLACED
R260	0662057N23	RES. CHIP 100K 5% 20X40
R301	0662057M67	RES. CHIP 510 5% 20X40
R302	0662057M74	RES. CHIP 1000 5% 20X40
R303	0662057M98	RES. CHIP 10K 5% 20X40
R304	0662057N39	RES. CHIP 470K 5% 20X40
R305	0662057N39	RES. CHIP 470K 5% 20X40
R307	0662057M98	RES. CHIP 10K 5% 20X40
R308	0662057M01	RES. CHIP 0 5% 20X40
R309	0662057M98	RES. CHIP 10K 5% 20X40
R310	0662057M78	RES. CHIP 1500 5% 20X40
R312	0662057N47	RES. CHIP 1.0 MEG 5% 20X40
R313	0662057N47	RES. CHIP 1.0 MEG 5% 20X40
R315	0662057M01	RES. CHIP 0 5% 20X40
R316	0662057M01	RES. CHIP 0 5% 20X40

Ref. Des.	Part Number	Description
R317	0662057M01	RES. CHIP 0 5% 20X40
R321	0662057M98	RES. CHIP 10K 5% 20X40
R325	0662057M98	RES. CHIP 10K 5% 20X40
R326	0662057M98	RES. CHIP 10K 5% 20X40
R327	0662057N23	RES. CHIP 100K 5% 20X40
R328	0662057M01	RES. CHIP 0 5% 20X40
R329	0662057M01	RES. CHIP 0 5% 20X40
R401	0662057M90	RES. CHIP 4700 5% 20X40
R402	0662057M01	RES. CHIP 0 5% 20X40
R403	0662057M01	RES. CHIP 0 5% 20X40
R405	0662057M01	RES. CHIP 0 5% 20X40
R406	0662057M01	RES. CHIP 0 5% 20X40
R413	0662057M01	RES. CHIP 0 5% 20X40
R414	0662057M98	RES. CHIP 10K 5% 20X40
R415	0662057M01	RES. CHIP 0 5% 20X40
R416	0662057M01	RES. CHIP 0 5% 20X40
R417	0662057M01	RES. CHIP 0 5% 20X40
R418	0662057M01	RES. CHIP 0 5% 20X40
R427	NOTPLACED	NOTPLACED
R428	0662057M64	RES. CHIP 390 5% 20X40
R429	0662057M64	RES. CHIP 390 5% 20X40
R430	0662057M64	RES. CHIP 390 5% 20X40
R431	0662057M64	RES. CHIP 390 5% 20X40
R432	0662057M64	RES. CHIP 390 5% 20X40
R433	0662057M64	RES. CHIP 390 5% 20X40
R434	0662057M64	RES. CHIP 390 5% 20X40
R435	0662057M64	RES. CHIP 390 5% 20X40
R440	NOTPLACED	NOTPLACED
R441	NOTPLACED	NOTPLACED
R450	0662057N15	RES. CHIP 47K 5% 20X40
R451	0662057M78	RES. CHIP 1500 5% 20X40
R452	0662057M42	RES. CHIP 47 5% 20X40
R453	0662057N11	RES. CHIP 33K 5% 20X40
R454	0662057M64	RES. CHIP 390 5% 20X40

Ref. Des.	Part Number	Description
R455	0662057M74	RES. CHIP 1000 5% 20X40
R456	NOTPLACED	NOTPLACED
R457	NOTPLACED	NOTPLACED
R458	0662057M98	RES. CHIP 10K 5% 20X40
R459	0662057M01	RES. CHIP 0 5% 20X40
R460	0662057M50	RES. CHIP 100 5% 20X40
R461	NOTPLACED	NOTPLACED
R501	0662057M01	RES. CHIP 0 5% 20X40
R502	0662057M01	RES. CHIP 0 5% 20X40
R503	0662057M01	RES. CHIP 0 5% 20X40
R504	0662057N06	RES. CHIP 20K 5% 20X40
R505	0662057M98	RES. CHIP 10K 5% 20X40
R510	0662057M98	RES. CHIP 10K 5% 20X40
R511	NOTPLACED	NOTPLACED
R514	0662057N06	RES. CHIP 20K 5% 20X40
R515	0662057N06	RES. CHIP 20K 5% 20X40
R516	0662057M67	RES. CHIP 510 5% 20X40
R519	0662057M98	RES. CHIP 10K 5% 20X40
R520	0662057U84	RES CHIP 2K 1% 1/16W
R522	0662057N15	RES. CHIP 47K 5% 20X40
R523	0662057N15	RES. CHIP 47K 5% 20X40
R524	0662057N17	RES. CHIP 56K 5% 20X40
R525	0662057N17	RES. CHIP 56K 5% 20X40
R526	0662057V02	RES CHIP 10K 1% 1/16W
R527	0662057M74	RES. CHIP 1000 5% 20X40
R528	0662057M74	RES. CHIP 1000 5% 20X40
R531	0662057M64	RES. CHIP 390 5% 20X40
R533	0662057M82	RES. CHIP 2200 5% 20X40
R536	0662057N23	RES. CHIP 100K 5% 20X40
R537	0662057N17	RES. CHIP 56K 5% 20X40
R538	0662057M01	RES. CHIP 0 5% 20X40
R539	0662057M01	RES. CHIP 0 5% 20X40
R540	0662057M95	RES. CHIP 7500 5% 20X40
R545	0662057M98	RES. CHIP 10K 5% 20X40



Ref. Des.	Part Number	Description
R548	0662057N06	RES. CHIP 20K 5% 20X40
R549	0662057M98	RES. CHIP 10K 5% 20X40
R550	0662057N17	RES. CHIP 56K 5% 20X40
R551	0662057N06	RES. CHIP 20K 5% 20X40
R553	0662057M98	RES. CHIP 10K 5% 20X40
R554	0662057N17	RES. CHIP 56K 5% 20X40
R555	0662057M74	RES. CHIP 1000 5% 20X40
R556	0662057N06	RES. CHIP 20K 5% 20X40
R557	0662057M98	RES. CHIP 10K 5% 20X40
R558	0662057M94	RES. CHIP 6800 5% 20X40
R559	0662057M98	RES. CHIP 10K 5% 20X40
R560	0662057M01	RES. CHIP 0 5% 20X40
R561	0662057M74	RES. CHIP 1000 5% 20X40
R563	0662057M64	RES. CHIP 390 5% 20X40
R564	0662057M98	RES. CHIP 10K 5% 20X40
R565	0662057M82	RES. CHIP 2200 5% 20X40
R566	0662057M95	RES. CHIP 7500 5% 20X40
R567	0662057N15	RES. CHIP 47K 5% 20X40
R568	0662057N15	RES. CHIP 47K 5% 20X40
R569	0662057M90	RES. CHIP 4700 5% 20X40
R572	0662057M50	RES. CHIP 100 5% 20X40
R573	0662057N23	RES. CHIP 100K 5% 20X40
R574	0662057N23	RES. CHIP 100K 5% 20X40
R575	0662057M98	RES. CHIP 10K 5% 20X40
R576	0662057N23	RES. CHIP 100K 5% 20X40
R577	0662057N15	RES. CHIP 47K 5% 20X40
R578	0662057N15	RES. CHIP 47K 5% 20X40
R579	NOTPLACED	NOTPLACED
R580	NOTPLACED	NOTPLACED
R581	0662057M01	RES. CHIP 0 5% 20X40
R582	0662057M90	RES. CHIP 4700 5% 20X40
R583	0662057M90	RES. CHIP 4700 5% 20X40
R584	0662057M98	RES. CHIP 10K 5% 20X40
R585	0662057M98	RES. CHIP 10K 5% 20X40

Ref. Des.	Part Number	Description
R586	0662057N39	RES. CHIP 470K 5% 20X40
R587	0662057M34	RES. CHIP 22 5% 20X40
R588	0662057M34	RES. CHIP 22 5% 20X40
R589	0662057M98	RES. CHIP 10K 5% 20X40
R590	NOTPLACED	NOTPLACED
R591	NOTPLACED	NOTPLACED
RESET_OUT	NOTPLACED	NOTPLACED
S101	NOTPLACED	NOTPLACED
SCKA	NOTPLACED	NOTPLACED
SCKB	NOTPLACED	NOTPLACED
TCK	NOTPLACED	NOTPLACED
TDI	NOTPLACED	NOTPLACED
TDO	NOTPLACED	NOTPLACED
TMS	NOTPLACED	NOTPLACED
TP201	NOTPLACED	NOTPLACED
TP202	NOTPLACED	NOTPLACED
TP206	NOTPLACED	NOTPLACED
TP207	NOTPLACED	NOTPLACED
TP208	NOTPLACED	NOTPLACED
TP209	NOTPLACED	NOTPLACED
TP210	NOTPLACED	NOTPLACED
TP211	NOTPLACED	NOTPLACED
TP212	NOTPLACED	NOTPLACED
TP213	NOTPLACED	NOTPLACED
TP214	NOTPLACED	NOTPLACED
TP215	NOTPLACED	NOTPLACED
TRST	NOTPLACED	NOTPLACED
U201	5109731C15	IC OP AMP SNGL OPA237 SOT23
U202	5109731C15	IC OP AMP SNGL OPA237 SOT23
U301	5185368C66	IC CUSTOM FLIPPER
U302	5105492X92	IC CMOS BILATERAL SWITCH

Ref. Des.	Part Number	Description
U303	5109522E53	IC SNGL BUF NC7S125P5X SC70
U401	5109841C69	IC 256 BGA 17X17 PACKAGE PATRIOT
U402	5199485A01	IC FLASH 8MBYTE BURST BGA
U403	5185368C82	IC 1.65 TO 2.2V, 70NS, 8MBIT SRAM
U404	5109522E53	IC SNGL BUF NC7S125P5X SC70
U405	5109522E53	IC SNGL BUF NC7S125P5X SC70
U406	5105492X03	IC SNG HI SPD L-MOS NOT GATE
U501	5109879E58	IC 4.3 GCAPII SN104616DGGMR BG
U502	5109731C15	IC OP AMP SNGL OPA237 SOT23
U503	5102463J44	IC AUDIO PA (PHILIPS_20PIN)
U504	5109731C15	IC OP AMP SNGL OPA237 SOT23
U505	5185353D13	IC MINI SO-8 HI PRECISION REG 5V
U507	5109731C15	IC OP AMP SNGL OPA237 SOT23
U509	5185353D35	IC DUAL EEPOT 256 TAP
U510	5105492X92	IC CMOS BILATERAL SWITCH
U511	5185353D56	IC 3.3V LINEAR REGULATOR MC78LC 33NTR
U512	NOTPLACED	NOTPLACED
VR201	4813832C72	TRANS SUP QUAD 12V
VR202	4813830A22	DIODE 9.1V 5% 225MW MMBZ5239B_
VR203	4813832C72	TRANS SUP QUAD 12V
VR204	4813830C26	DIODE 13V 'H3' MMSZ5243BT1
VR205	4805656W08	DIODE ZENER QUAD
VR206	4805656W08	DIODE ZENER QUAD
VR209	4813832C72	TRANS SUP QUAD 12V

Ref. Des.	Part Number	Description
VR220	4805656W03	DIODE DUAL 5.6V ZENER
VR221	4805656W03	DIODE DUAL 5.6V ZENER
VR501	4813830A15	DIODE 5.6V 5% 225MW MMBZ5232B_
WAIT	NOTPLACED	NOTPLACED
Y301	4809995L05	XTAL QUARTZ 32.768KHZ CC4V-T1

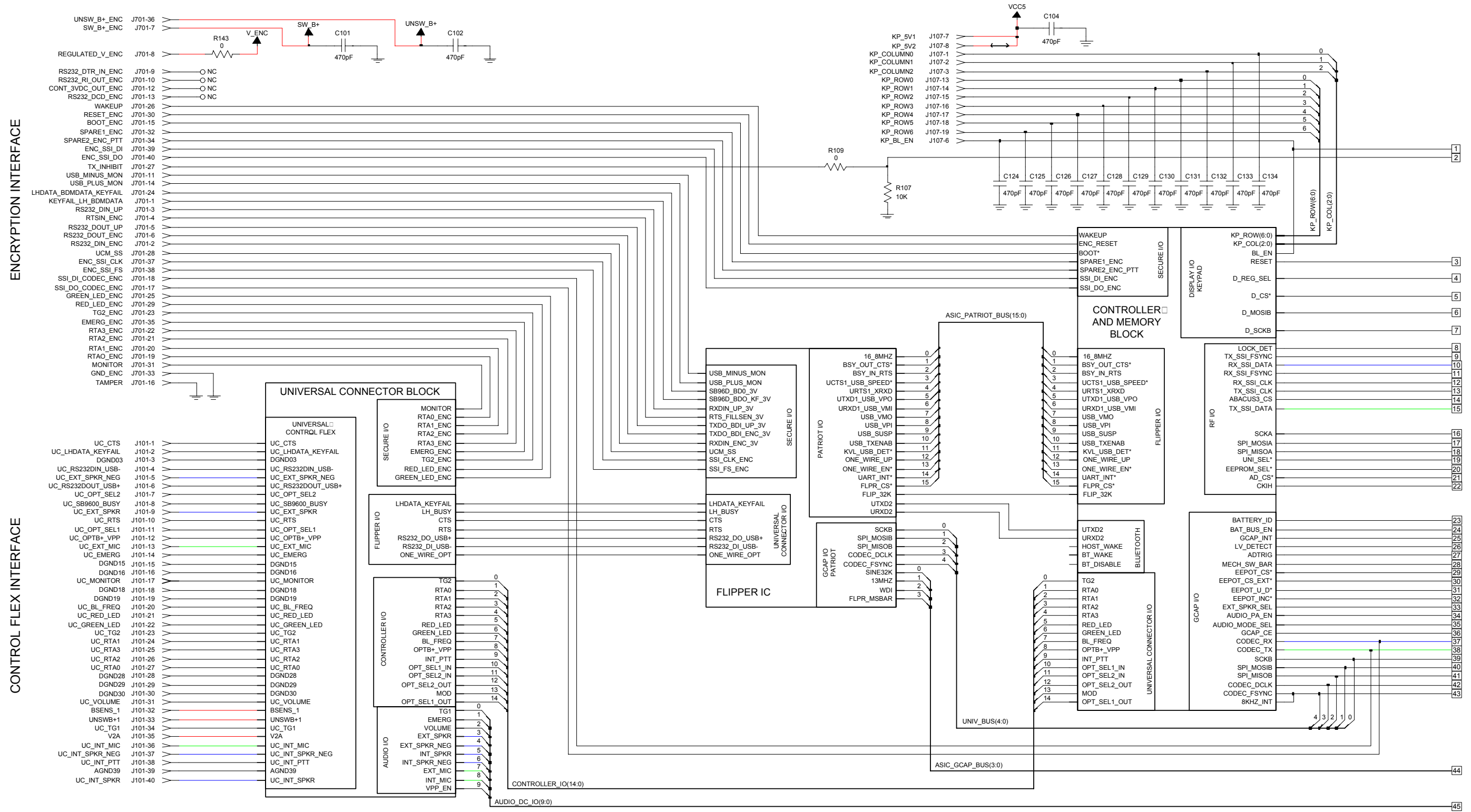

63B81096C52-0  
SHEET 1

Figure 8-79. NNTN4563A/B VOCON Board Overall Schematic—1 of 2

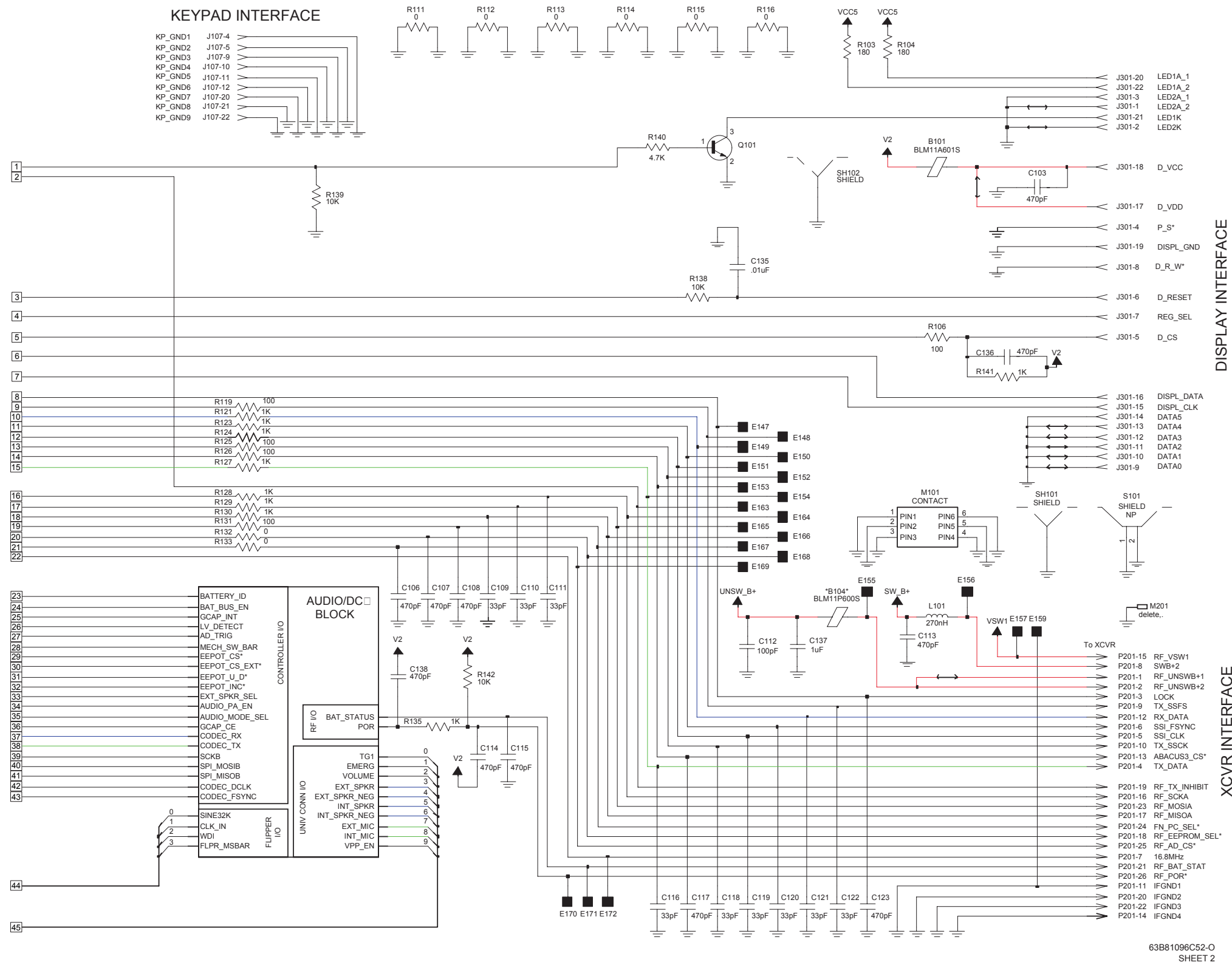

Figure 8-80. NNTN4563A/B VOCON Board Overall Schematic—2 of 2

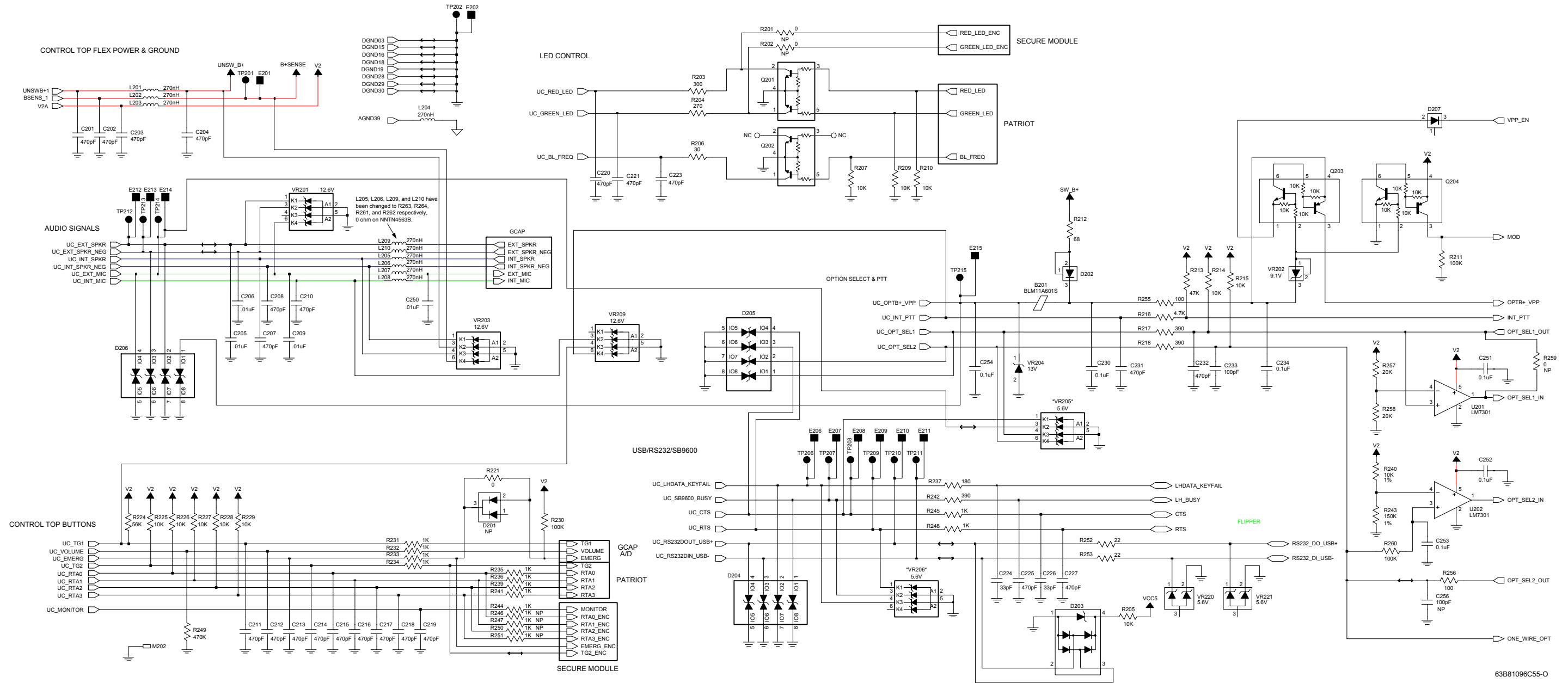

Figure 8-81. NNTN4563A/B VOCON Universal Connector Circuit

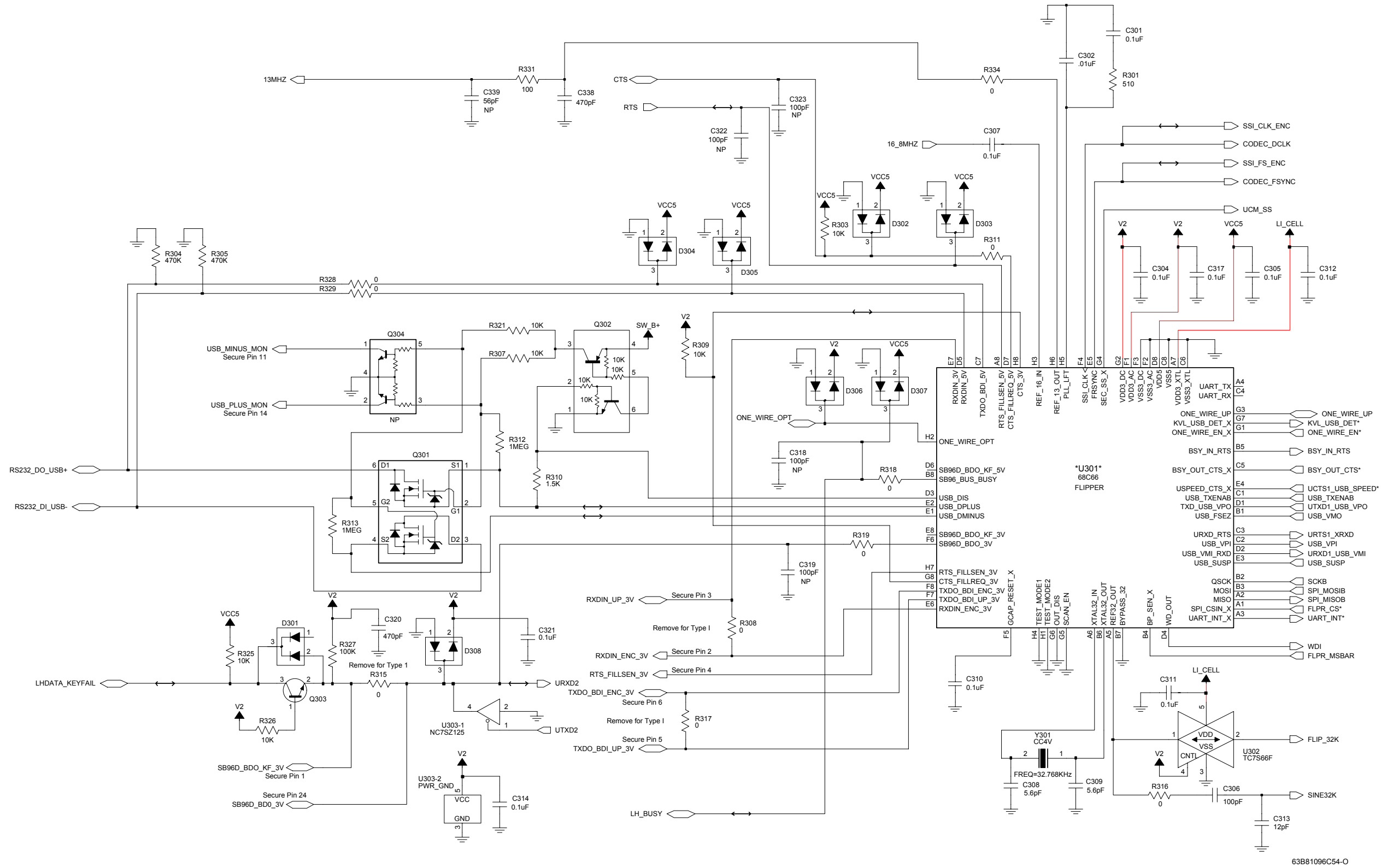

Figure 8-82. NNTN4563A/B VOCON Flipper Circuit

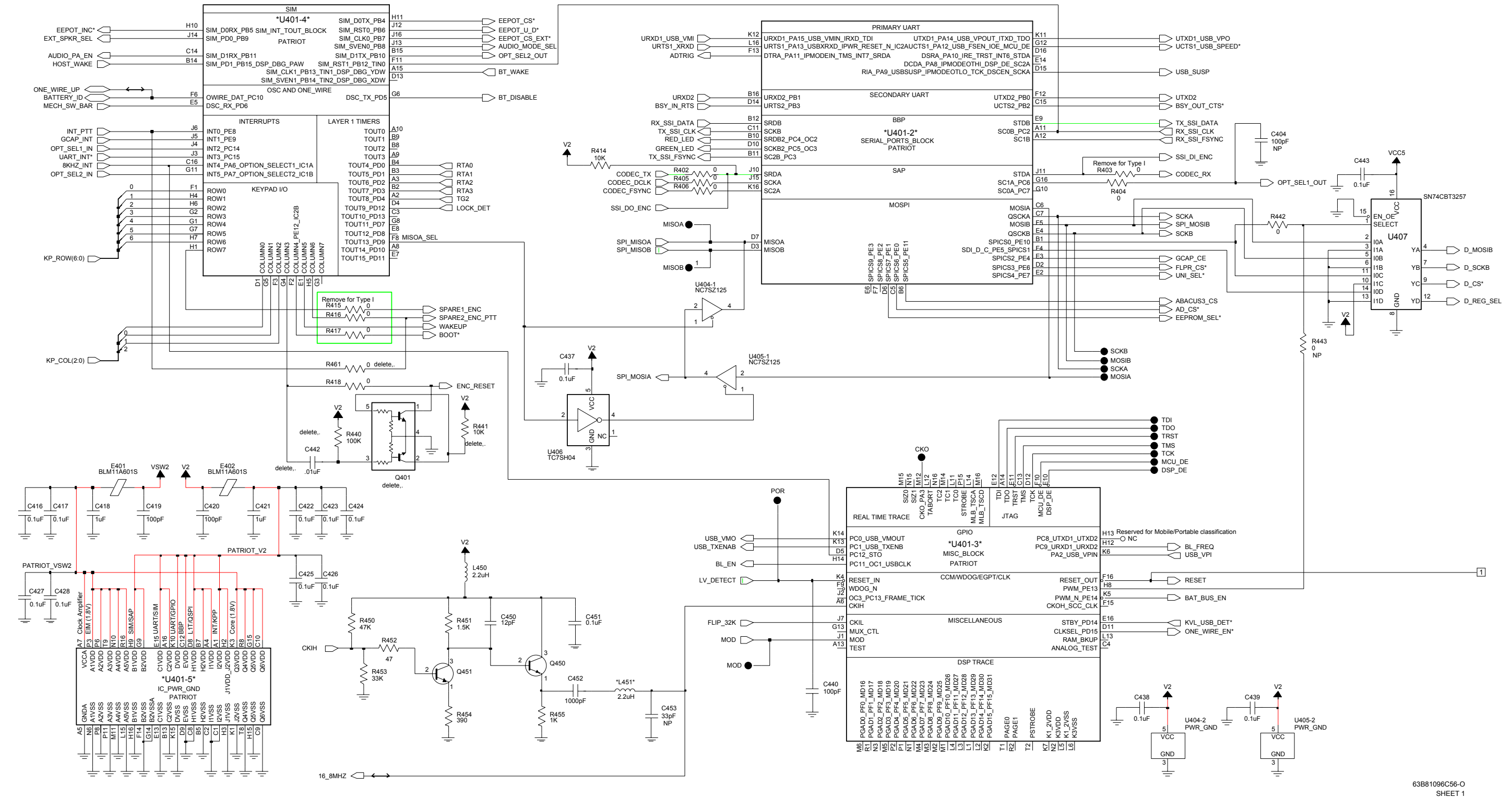

Figure 8-83. NNTN4563A/B VOCON Controller and Memory Circuits—1 of 2

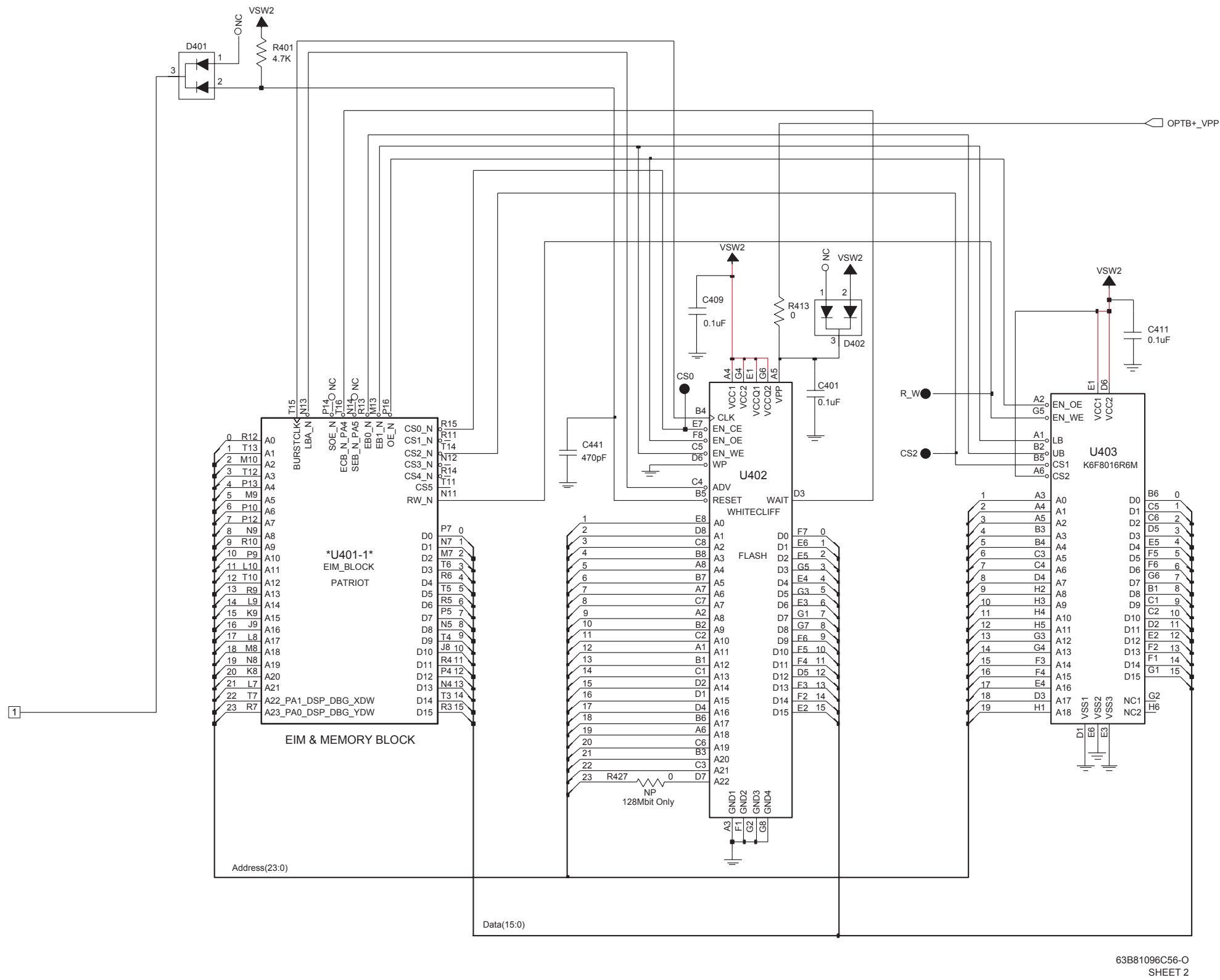

Figure 8-84. NNTN4563A/B VOCON Controller and Memory Circuits—2 of 2







VIEWED FROM SIDE 1

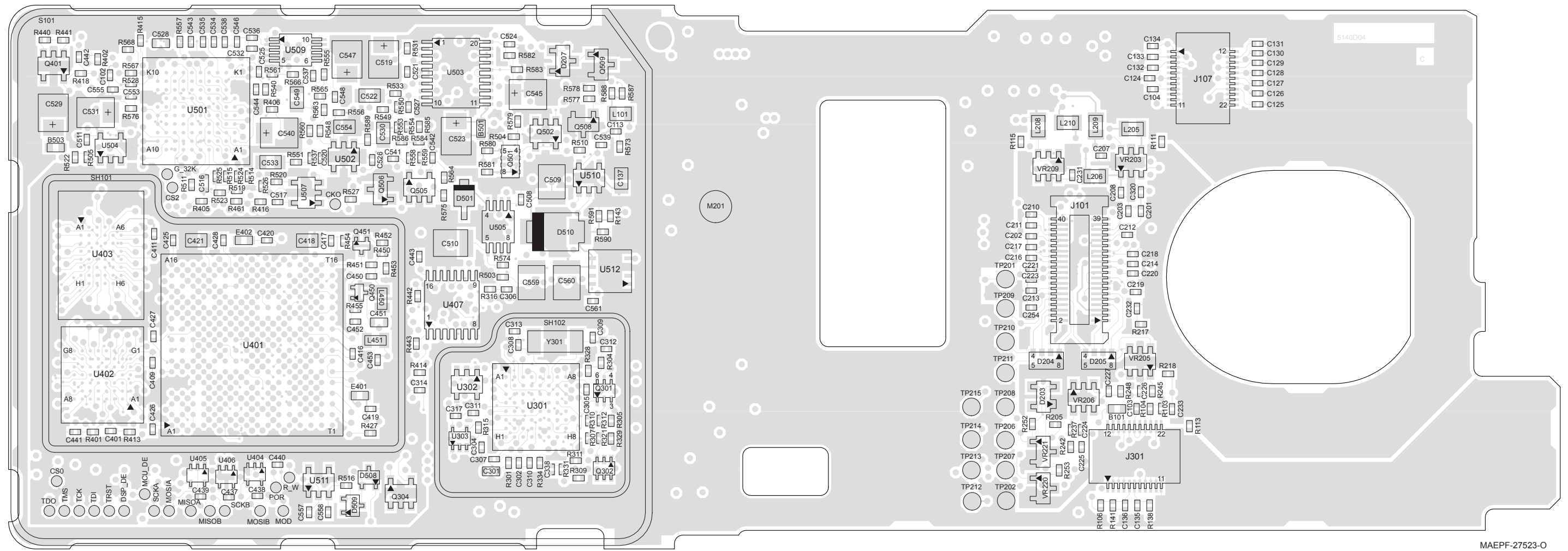

MAEPF-27523-O

**Note:** The following table shows components that have been changed between board versions:

NNTN4563A	NNTN4563B
L205	R263
L206	R264
L209	R261
L210	R262
B501	R595

Figure 8-86. NNTN4563A/B VOCON Board Layout—Side 1

VIEWED FROM SIDE 2

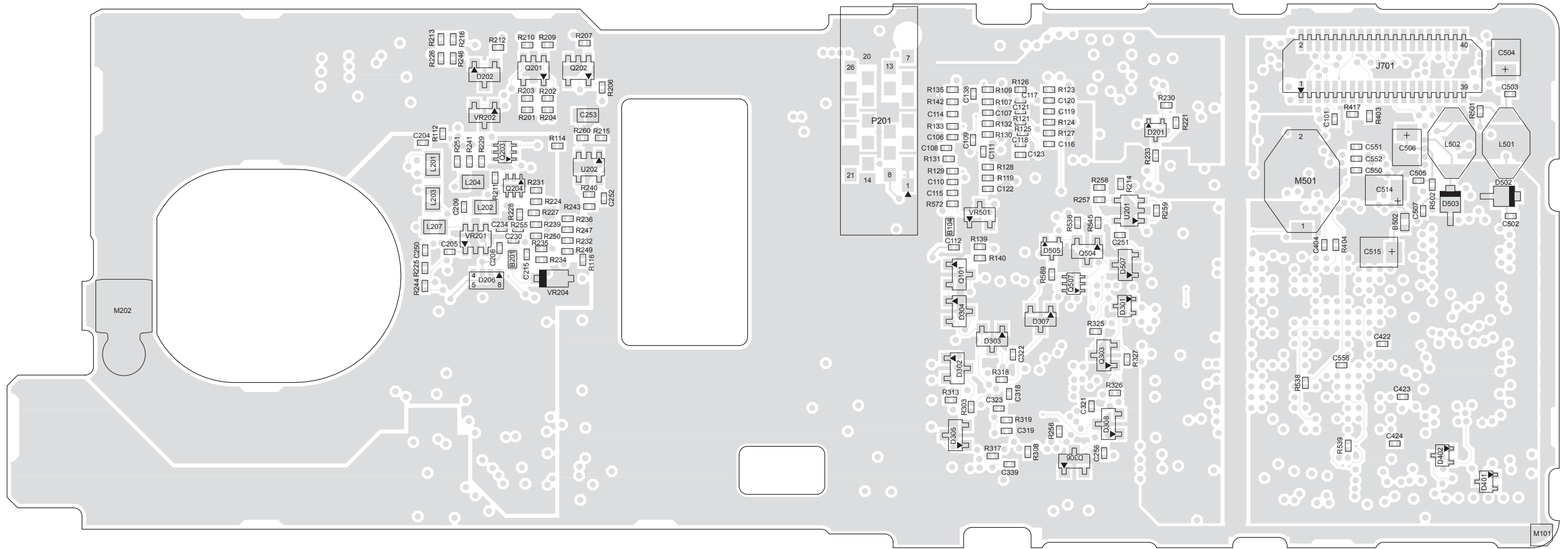

MAEPF-27524-O

Figure 8-87. NNTN4563A/B VOCON Board Layout—Side 2

## NNTN4563A/B VOCON Board Parts List

Ref Des	Part #	Description
—	1105033S02	RIBBON LABEL LT. PACK LABEL
—	1105033S13	RIBBON LBL
—	5405569Y02	LBL BARCODE APC
—	5405569Y03	LABEL BARCODE
—	5685647D01	UNI-BOARD CLAMSHELL
—	6003710K08	BATT COIN 3.3V LIION
B101	2480574F01	IND FERRITE CHIP 600 OHM 0603
B104	2462586G33	INDUCTOR CHIP FERRITE BEADS
B201	2480574F01	IND FERRITE CHIP 600 OHM 0603
B501	2480574F01	IND FERRITE CHIP 600 OHM 0603 (NNTN4563A only)
B502	2480574F01	IND FERRITE CHIP 600 OHM 0603
B503	2480574F01	IND FERRITE CHIP 600 OHM 0603
C101	2113743L09	CAP CHIP 470 PF 10% X7R
C102	2113743L09	CAP CHIP 470 PF 10% X7R
C103	2113743L09	CAP CHIP 470 PF 10% X7R
C104	2113743L09	CAP CHIP 470 PF 10% X7R
C106	2113743L09	CAP CHIP 470 PF 10% X7R
C107	2113743L09	CAP CHIP 470 PF 10% X7R
C108	2113743L09	CAP CHIP 470 PF 10% X7R
C109	2113743N38	CAP CHIP 33.0 PF 5% COG
C110	2113743N38	CAP CHIP 33.0 PF 5% COG
C111	2113743N38	CAP CHIP 33.0 PF 5% COG
C112	2113743N50	CAP CHIP 100 PF 5% COG
C113	2113743L09	CAP CHIP 470 PF 10% X7R
C114	2113743L09	CAP CHIP 470 PF 10% X7R
C115	2113743L09	CAP CHIP 470 PF 10% X7R
C116	2113743N38	CAP CHIP 33.0 PF 5% COG

Ref Des	Part #	Description
C117	2113743L09	CAP CHIP 470 PF 10% X7R
C118	2113743N38	CAP CHIP 33.0 PF 5% COG
C119	2113743N38	CAP CHIP 33.0 PF 5% COG
C120	2113743N38	CAP CHIP 33.0 PF 5% COG
C121	2113743N38	CAP CHIP 33.0 PF 5% COG
C122	2113743N38	CAP CHIP 33.0 PF 5% COG
C123	2113743L09	CAP CHIP 470 PF 10% X7R
C124	2113743L09	CAP CHIP 470 PF 10% X7R
C125	2113743L09	CAP CHIP 470 PF 10% X7R
C126	2113743L09	CAP CHIP 470 PF 10% X7R
C127	2113743L09	CAP CHIP 470 PF 10% X7R
C128	2113743L09	CAP CHIP 470 PF 10% X7R
C129	2113743L09	CAP CHIP 470 PF 10% X7R
C130	2113743L09	CAP CHIP 470 PF 10% X7R
C131	2113743L09	CAP CHIP 470 PF 10% X7R
C132	2113743L09	CAP CHIP 470 PF 10% X7R
C133	2113743L09	CAP CHIP 470 PF 10% X7R
C134	2113743L09	CAP CHIP 470 PF 10% X7R
C135	2113743L41	CAP CHIP 10000 PF 10% X7R
C136	2113743L09	CAP CHIP 470 PF 10% X7R
C137	2113743A31	CAP CHIP 1.0UF 10% X7R
C138	2113743L09	CAP CHIP 470 PF 10% X7R
C201	2113743L09	CAP CHIP 470 PF 10% X7R
C202	2113743L09	CAP CHIP 470 PF 10% X7R
C203	2113743L09	CAP CHIP 470 PF 10% X7R
C204	2113743L09	CAP CHIP 470 PF 10% X7R
C205	2113743L41	CAP CHIP 10000 PF 10% X7R
C206	2113743L41	CAP CHIP 10000 PF 10% X7R
C207	2113743L09	CAP CHIP 470 PF 10% X7R
C208	2113743L09	CAP CHIP 470 PF 10% X7R

Ref Des	Part #	Description
C209	2113743L41	CAP CHIP 10000 PF 10% X7R
C210	2113743L09	CAP CHIP 470 PF 10% X7R
C211	2113743L09	CAP CHIP 470 PF 10% X7R
C212	2113743L09	CAP CHIP 470 PF 10% X7R
C213	2113743L09	CAP CHIP 470 PF 10% X7R
C214	2113743L09	CAP CHIP 470 PF 10% X7R
C215	2113743L09	CAP CHIP 470 PF 10% X7R
C216	2113743L09	CAP CHIP 470 PF 10% X7R
C217	2113743L09	CAP CHIP 470 PF 10% X7R
C218	2113743L09	CAP CHIP 470 PF 10% X7R
C219	2113743L09	CAP CHIP 470 PF 10% X7R
C220	2113743L09	CAP CHIP 470 PF 10% X7R
C221	2113743L09	CAP CHIP 470 PF 10% X7R
C223	2113743L09	CAP CHIP 470 PF 10% X7R
C224	2113743N38	CAP CHIP 33.0 PF 5% COG
C225	2113743L09	CAP CHIP 470 PF 10% X7R
C226	2113743N38	CAP CHIP 33.0 PF 5% COG
C227	2113743L09	CAP CHIP 470 PF 10% X7R
C230	2113743M24	CAP CHIP 100000 PF +80-20% Y5V
C231	2113743L09	CAP CHIP 470 PF 10% X7R
C232	2113743L09	CAP CHIP 470 PF 10% X7R
C233	2113743N50	CAP CHIP 100 PF 5% COG
C234	2113743M24	CAP CHIP 100000 PF +80-20% Y5V
C250	2113743L41	CAP CHIP 10000 PF 10% X7R
C251	2113743M24	CAP CHIP 100000 PF +80-20% Y5V
C252	2113743M24	CAP CHIP 100000 PF +80-20% Y5V
C253	2113743A19	CAP CHIP .100 UF 10% X7R
C254	2113743M24	CAP CHIP 100000 PF +80-20% Y5V

Ref Des	Part #	Description
C256	NOTPLACED	NOTPLACED
C301	2113743E20	CAP CHIP .10 UF 10%
C302	2113743L41	CAP CHIP 10000 PF 10% X7R
C304	2113743M24	CAP CHIP 100000 PF +80-20% Y5V
C305	2113743M24	CAP CHIP 100000 PF +80-20% Y5V
C306	2113743N50	CAP CHIP 100 PF 5% COG
C307	2113743M24	CAP CHIP 100000 PF +80-20% Y5V
C308	2113743N20	CAP CHIP 5.6PF +/- .5PF COG
C309	2113743N20	CAP CHIP 5.6PF +/- .5PF COG
C310	2113743M24	CAP CHIP 100000 PF +80-20% Y5V
C311	2113743M24	CAP CHIP 100000 PF +80-20% Y5V
C312	2113743M24	CAP CHIP 100000 PF +80-20% Y5V
C313	2113743N28	CAP CHIP 12.0 PF 5% COG
C314	2113743M24	CAP CHIP 100000 PF +80-20% Y5V
C317	2113743M24	CAP CHIP 100000 PF +80-20% Y5V
C318	NOTPLACED	NOTPLACED
C319	NOTPLACED	NOTPLACED
C320	2113743L09	CAP CHIP 470 PF 10% X7R
C321	2113743M24	CAP CHIP 100000 PF +80-20% Y5V
C322	NOTPLACED	NOTPLACED
C323	NOTPLACED	NOTPLACED
C338	2113743L09	CAP CHIP 470 PF 10% X7R
C339	NOTPLACED	NOTPLACED
C401	2113743M24	CAP CHIP 100000 PF +80-20% Y5V
C404	NOTPLACED	NOTPLACED

Ref Des	Part #	Description
C409	2113743M24	CAP CHIP 100000 PF +80-20% Y5V
C411	2113743M24	CAP CHIP 100000 PF +80-20% Y5V
C416	2113743M24	CAP CHIP 100000 PF +80-20% Y5V
C417	2113743M24	CAP CHIP 100000 PF +80-20% Y5V
C418	2113743A31	CAP CHIP 1.0UF 10% X7R
C419	2113743N50	CAP CHIP 100 PF 5% COG
C420	2113743N50	CAP CHIP 100 PF 5% COG
C421	2113743A31	CAP CHIP 1.0UF 10% X7R
C422	2113743M24	CAP CHIP 100000 PF +80-20% Y5V
C423	2113743M24	CAP CHIP 100000 PF +80-20% Y5V
C424	2113743M24	CAP CHIP 100000 PF +80-20% Y5V
C425	2113743M24	CAP CHIP 100000 PF +80-20% Y5V
C426	2113743M24	CAP CHIP 100000 PF +80-20% Y5V
C427	2113743M24	CAP CHIP 100000 PF +80-20% Y5V
C428	2113743M24	CAP CHIP 100000 PF +80-20% Y5V
C437	2113743M24	CAP CHIP 100000 PF +80-20% Y5V
C438	2113743M24	CAP CHIP 100000 PF +80-20% Y5V
C439	2113743M24	CAP CHIP 100000 PF +80-20% Y5V
C440	2113743N50	CAP CHIP 100 PF 5% COG
C441	2113743L09	CAP CHIP 470 PF 10% X7R
C442	NOTPLACED	NOTPLACED
C443	2113743M24	CAP CHIP 100000 PF +80-20% Y5V
C450	2113743N28	CAP CHIP 12.0 PF 5% COG
C451	2113743E20	CAP CHIP .10 UF 10%

Ref Des	Part #	Description
C452	2113743L17	CAP CHIP 1000 PF 10% X7R
C453	NOTPLACED	NOTPLACED
C502	2113743N50	CAP CHIP 100 PF 5% COG
C503	2113743N50	CAP CHIP 100 PF 5% COG
C504	2311049C52	CAP TANT CHIP 33UF 10% 10V
C505	2113743N50	CAP CHIP 100 PF 5% COG
C506	2311049C52	CAP TANT CHIP 33UF 10% 10V
C507	2113743N50	CAP CHIP 100 PF 5% COG
C508	2113743L41	CAP CHIP 10000 PF 10% X7R
C509	2113743T19	CAP 10UF 16V CER 3225 X5R
C510	2113743T19	CAP 10UF 16V CER 3225 X5R
C511	2113743M24	CAP CHIP 100000 PF +80-20% Y5V
C514	2311049A57	CAP TANT CHIP A/P 10UF 10% 16V
C515	2311049A57	CAP TANT CHIP A/P 10UF 10% 16V
C516	2113743E11	CAP CHIP .039 UF 10% X7R
C517	2113743M24	CAP CHIP 100000 PF +80-20% Y5V
C519	2311049A57	CAP TANT CHIP A/P 10UF 10% 16V
C520	2113743L01 2113743L05	CAP CHIP 220 PF 10% X7R (NNTN4563A) CAP CHIP 330 PF 10% X7R (NNTN4563B)
C521	2113743N50	CAP CHIP 100 PF 5% COG
C522	2113743A31	CAP CHIP 1.0UF 10% X7R
C523	2311049A57	CAP TANT CHIP A/P 10UF 10% 16V
C524	2113743M24	CAP CHIP 100000 PF +80-20% Y5V
C525	2113743N50	CAP CHIP 100 PF 5% COG

Ref Des	Part #	Description
C526	2113743M24	CAP CHIP 100000 PF +80-20% Y5V
C527	2113743L01 2113743N54	CAP CHIP 220 PF 10% X7R (NNTN4563A) CAP CHIP 150 PF 10% X7R (NNTN4563B)
C528	2113743E11	CAP CHIP .039 UF 10% X7R
C529	2311049A57	CAP TANT CHIP A/P 10UF 10% 16V
C530	2113743A19	CAP CHIP .100 UF 10% X7R
C531	2311049A57	CAP TANT CHIP A/P 10UF 10% 16V
C532	2113743M24	CAP CHIP 100000 PF +80-20% Y5V
C533	2113743A31	CAP CHIP 1.0UF 10% X7R
C534	NOTPLACED	NOTPLACED
C535	2113743M24	CAP CHIP 100000 PF +80-20% Y5V
C536	2113743N50	CAP CHIP 100 PF 5% COG
C537	2113743N50	CAP CHIP 100 PF 5% COG
C538	2113743N50	CAP CHIP 100 PF 5% COG
C539	2113743M24	CAP CHIP 100000 PF +80-20% Y5V
C540	2311049A57	CAP TANT CHIP A/P 10UF 10% 16V
C541	2113743M24	CAP CHIP 100000 PF +80-20% Y5V
C542	2113743M24	CAP CHIP 100000 PF +80-20% Y5V
C543	2113743M24	CAP CHIP 100000 PF +80-20% Y5V
C544	2113743M24	CAP CHIP 100000 PF +80-20% Y5V
C545	2311049A57	CAP TANT CHIP A/P 10UF 10% 16V
C546	2113743N50	CAP CHIP 100 PF 5% COG
C547	2311049A57	CAP TANT CHIP A/P 10UF 10% 16V

Ref Des	Part #	Description
C548	2113743N50	CAP CHIP 100 PF 5% COG
C549	2113743A31	CAP CHIP 1.0UF 10% X7R
C550	2113743M24	CAP CHIP 100000 PF +80-20% Y5V
C551	2113743M24	CAP CHIP 100000 PF +80-20% Y5V
C552	2113743M24	CAP CHIP 100000 PF +80-20% Y5V
C553	2113743L41	CAP CHIP 10000 PF 10% X7R
C554	2113743A31	CAP CHIP 1.0UF 10% X7R
C555	2113743M24	CAP CHIP 100000 PF +80-20% Y5V
C556	2113743N38	CAP CHIP 33.0 PF 5% COG
C557	2113743M24	CAP CHIP 100000 PF +80-20% Y5V
C558	2113743M24	CAP CHIP 100000 PF +80-20% Y5V
C559	NOTPLACED	NOTPLACED
C560	NOTPLACED	NOTPLACED
C561	NOTPLACED	NOTPLACED
CKO	NOTPLACED	NOTPLACED
CS0	NOTPLACED	NOTPLACED
CS2	NOTPLACED	NOTPLACED
D201	NOTPLACED	NOTPLACED
D202	4805129M90	DIODE SOT PKGD
D203	4802021P15	ZENER SR05
D204	4805656W39	QUAD ESD SUPPRESSOR ARRAY -
D205	4805656W39	QUAD ESD SUPPRESSOR ARRAY -
D206	4805656W39	QUAD ESD SUPPRESSOR ARRAY -
D207	4805129M90	DIODE SOT PKGD
D301	4805218N57	DIODE DUAL
D302	4805129M06	DIODE MMBD7000
D303	4805129M06	DIODE MMBD7000

Ref Des	Part #	Description
D304	4805129M06	DIODE MMBD7000
D305	4805129M06	DIODE MMBD7000
D306	4805129M06	DIODE MMBD7000
D307	4805129M06	DIODE MMBD7000
D308	4805129M06	DIODE MMBD7000
D401	4805218N57	DIODE DUAL
D402	4805218N57	DIODE DUAL
D501	4813833A20	DIODE SCHOTTKY 1A 40V PWRMITE
D502	4813833A20	DIODE SCHOTTKY 1A 40V PWRMITE
D503	4813833A20	DIODE SCHOTTKY 1A 40V PWRMITE
D505	4805218N57	DIODE DUAL
D507	4805129M06	DIODE MMBD7000
D508	4805218N57	DIODE DUAL
D509	4805218N57	DIODE DUAL
D510	NOTPLACED	NOTPLACED
DSP_DE	NOTPLACED	NOTPLACED
E147	NOTPLACED	NOTPLACED
E148	NOTPLACED	NOTPLACED
E149	NOTPLACED	NOTPLACED
E150	NOTPLACED	NOTPLACED
E151	NOTPLACED	NOTPLACED
E152	NOTPLACED	NOTPLACED
E153	NOTPLACED	NOTPLACED
E154	NOTPLACED	NOTPLACED
E155	NOTPLACED	NOTPLACED
E156	NOTPLACED	NOTPLACED
E157	NOTPLACED	NOTPLACED
E159	NOTPLACED	NOTPLACED
E163	NOTPLACED	NOTPLACED
E164	NOTPLACED	NOTPLACED
E165	NOTPLACED	NOTPLACED

Ref Des	Part #	Description
E166	NOTPLACED	NOTPLACED
E167	NOTPLACED	NOTPLACED
E168	NOTPLACED	NOTPLACED
E169	NOTPLACED	NOTPLACED
E170	NOTPLACED	NOTPLACED
E171	NOTPLACED	NOTPLACED
E172	NOTPLACED	NOTPLACED
E201	NOTPLACED	NOTPLACED
E202	NOTPLACED	NOTPLACED
E206	NOTPLACED	NOTPLACED
E207	NOTPLACED	NOTPLACED
E208	NOTPLACED	NOTPLACED
E209	NOTPLACED	NOTPLACED
E210	NOTPLACED	NOTPLACED
E211	NOTPLACED	NOTPLACED
E212	NOTPLACED	NOTPLACED
E213	NOTPLACED	NOTPLACED
E214	NOTPLACED	NOTPLACED
E215	NOTPLACED	NOTPLACED
E401	2480574F01	IND FERRITE CHIP 600 OHM 0603
E402	2480574F01	IND FERRITE CHIP 600 OHM 0603
G_32K	NOTPLACED	NOTPLACED
J101	0985185D01	CONN RECEPT 0.5MM PITCH 40 CKTS
J107	0987817K01	RECP BTB 0.5P 1.5 STACK SMD
J301	0987817K01	RECP BTB 0.5P 1.5 STACK SMD
J701	0980423L02	40PIN ROBIN CONN 3MM
L101	2404574Z14	IND CHIP WW 270NH 2% 2012 SMD
L201	2404574Z14	IND CHIP WW 270NH 2% 2012 SMD

Ref Des	Part #	Description
L202	2404574Z14	IND CHIP WW 270NH 2% 2012 SMD
L203	2404574Z14	IND CHIP WW 270NH 2% 2012 SMD
L204	2404574Z14	IND CHIP WW 270NH 2% 2012 SMD
L205	2404574Z14	IND CHIP WW 270NH 2% 2012 SMD (NNTN4563A only)
L206	2404574Z14	IND CHIP WW 270NH 2% 2012 SMD (NNTN4563A only)
L207	2404574Z14	IND CHIP WW 270NH 2% 2012 SMD
L208	2404574Z14	IND CHIP WW 270NH 2% 2012 SMD
L209	2404574Z14	IND CHIP WW 270NH 2% 2012 SMD (NNTN4563A only)
L210	2404574Z14	IND CHIP WW 270NH 2% 2012 SMD (NNTN4563A only)
L450	2462587Q20	IND CHIP 2,200 NH 20%
L451	0662057C01	CHIP RES 0 OHMS +.050 OHMS
L501	2486085A06	COIL 47UH SMT POWER INDUCTOR
L502	2486085A06	COIL 47UH SMT POWER INDUCTOR
M201	NOTPLACED	NOTPLACED
M202	3985951A01	CONTACT ANTENNA GROUND
M501	0985888K02	SKT RTC BTTY LEAP
MCU_DE	NOTPLACED	NOTPLACED
MISOA	NOTPLACED	NOTPLACED
MISOB	NOTPLACED	NOTPLACED
MOD	NOTPLACED	NOTPLACED
MOSIA	NOTPLACED	NOTPLACED
MOSIB	NOTPLACED	NOTPLACED
P201	NOTPLACED	NOTPLACED

Ref Des	Part #	Description
PCB	8485140D04	PCB MAIN
POR	NOTPLACED	NOTPLACED
Q101	4813824A10	TSTR NPN 40V .2A GEN PURP
Q201	4805921T09	XSTR DUAL ROHM FMG8
Q202	4805921T09	XSTR DUAL ROHM FMG8
Q203	4805723X03	TRANS DUAL NPN-PNP UMD3N ROHM
Q204	4805723X03	TRANS DUAL NPN-PNP UMD3N ROHM
Q301	4809579E35	TSTR FET DUAL N-CHAN FDG3601N
Q302	4805723X03	TRANS DUAL NPN-PNP UMD3N ROHM
Q303	4813824A10	TSTR NPN 40V .2A GEN PURP
Q304	NOTPLACED	NOTPLACED
Q401	NOTPLACED	NOTPLACED
Q450	4805793Y01	TRANS MINI SOT NPN LOW NOISE
Q451	4805793Y01	TRANS MINI SOT NPN LOW NOISE
Q501	4885844C01	XSTR FET
Q502	4805921T09	XSTR DUAL ROHM FMG8
Q504	4813824A10	TSTR NPN 40V .2A GEN PURP
Q505	4805921T09	XSTR DUAL ROHM FMG8
Q506	4813824A10	TSTR NPN 40V .2A GEN PURP
Q507	4805723X03	TRANS DUAL NPN-PNP UMD3N ROHM
Q508	4813824A10	TSTR NPN 40V .2A GEN PURP
Q509	4805218N11	XISTOR SOT RH BST82
R_W	NOTPLACED	NOTPLACED
R103	0662057M56	RES. CHIP 180 5% 20X40
R104	0662057M56	RES. CHIP 180 5% 20X40
R106	0662057M50	RES. CHIP 100 5% 20X40

Ref Des	Part #	Description
R107	0662057M98	RES. CHIP 10K 5% 20X40
R109	0662057M01	RES. CHIP 0 5% 20X40
R111	0662057M01	RES. CHIP 0 5% 20X40
R112	0662057M01	RES. CHIP 0 5% 20X40
R113	0662057M01	RES. CHIP 0 5% 20X40
R114	0662057M01	RES. CHIP 0 5% 20X40
R115	0662057M01	RES. CHIP 0 5% 20X40
R116	0662057M01	RES. CHIP 0 5% 20X40
R119	0662057M50	RES. CHIP 100 5% 20X40
R121	0662057M74	RES. CHIP 1000 5% 20X40
R123	0662057M74	RES. CHIP 1000 5% 20X40
R124	0662057M74	RES. CHIP 1000 5% 20X40
R125	0662057M50	RES. CHIP 100 5% 20X40
R126	0662057M50	RES. CHIP 100 5% 20X40
R127	0662057M74	RES. CHIP 1000 5% 20X40
R128	0662057M74	RES. CHIP 1000 5% 20X40
R129	0662057M74	RES. CHIP 1000 5% 20X40
R130	0662057M74	RES. CHIP 1000 5% 20X40
R131	0662057M50	RES. CHIP 100 5% 20X40
R132	0662057M01	RES. CHIP 0 5% 20X40
R133	0662057M01	RES. CHIP 0 5% 20X40
R135	0662057M74	RES. CHIP 1000 5% 20X40
R138	0662057M98	RES. CHIP 10K 5% 20X40
R139	0662057M98	RES. CHIP 10K 5% 20X40
R140	0662057M90	RES. CHIP 4700 5% 20X40
R141	0662057M74	RES. CHIP 1000 5% 20X40
R142	0662057M98	RES. CHIP 10K 5% 20X40
R143	0662057M01	RES. CHIP 0 5% 20X40
R201	NOTPLACED	NOTPLACED
R202	NOTPLACED	NOTPLACED
R203	0662057M61	RES. CHIP 300 5% 20X40
R204	0662057M60	RES. CHIP 270 5% 20X40
R205	0662057M98	RES. CHIP 10K 5% 20X40

Ref Des	Part #	Description
R206	0662057M37	20X40 30 OMH 5% CHIP RESISTOR
R207	0662057M98	RES. CHIP 10K 5% 20X40
R209	0662057M98	RES. CHIP 10K 5% 20X40
R210	0662057M98	RES. CHIP 10K 5% 20X40
R211	0662057N23	RES. CHIP 100K 5% 20X40
R212	0662057M46	RES. CHIP 68 5% 20X40
R213	0662057N15	RES. CHIP 47K 5% 20X40
R214	0662057M98	RES. CHIP 10K 5% 20X40
R215	0662057M98	RES. CHIP 10K 5% 20X40
R216	0662057M90	RES. CHIP 4700 5% 20X40
R217	0662057M64	RES. CHIP 390 5% 20X40
R218	0662057M64	RES. CHIP 390 5% 20X40
R221	0662057M01	RES. CHIP 0 5% 20X40
R224	0662057N17	RES. CHIP 56K 5% 20X40
R225	0662057M98	RES. CHIP 10K 5% 20X40
R226	0662057M98	RES. CHIP 10K 5% 20X40
R227	0662057M98	RES. CHIP 10K 5% 20X40
R228	0662057M98	RES. CHIP 10K 5% 20X40
R229	0662057M98	RES. CHIP 10K 5% 20X40
R230	0662057N23	RES. CHIP 100K 5% 20X40
R231	0662057M74	RES. CHIP 1000 5% 20X40
R232	0662057M74	RES. CHIP 1000 5% 20X40
R233	0662057M74	RES. CHIP 1000 5% 20X40
R234	0662057M74	RES. CHIP 1000 5% 20X40
R235	0662057M74	RES. CHIP 1000 5% 20X40
R236	0662057M74	RES. CHIP 1000 5% 20X40
R237	0662057M56	RES. CHIP 180 5% 20X40
R239	0662057M74	RES. CHIP 1000 5% 20X40
R240	0662057V02	RES CHIP 10K 1% 1/16W
R241	0662057M74	RES. CHIP 1000 5% 20X40
R242	0662057M64	RES. CHIP 390 5% 20X40

Ref Des	Part #	Description
R243	0662057V32	RESISTOR, 150 KOHM, 20X40, 1%
R244	0662057M74	RES. CHIP 1000 5% 20X40
R245	0662057M74	RES. CHIP 1000 5% 20X40
R246	NOTPLACED	NOTPLACED
R247	NOTPLACED	NOTPLACED
R248	0662057M74	RES. CHIP 1000 5% 20X40
R249	0662057N39	RES. CHIP 470K 5% 20X40
R250	NOTPLACED	NOTPLACED
R251	NOTPLACED	NOTPLACED
R252	0662057M34	RES. CHIP 22 5% 20X40
R253	0662057M34	RES. CHIP 22 5% 20X40
R255	0662057M50	RES. CHIP 100 5% 20X40
R256	0662057M50	RES. CHIP 100 5% 20X40
R257	0662057N06	RES. CHIP 20K 5% 20X40
R258	0662057N06	RES. CHIP 20K 5% 20X40
R259	NOTPLACED	NOTPLACED
R260	0662057N23	RES. CHIP 100K 5% 20X40
R261	0662057C01	RES. CHIP 0 5% 80X50 (NNTN4563B only)
R262	0662057C01	RES. CHIP 0 5% 80X50 (NNTN4563B only)
R263	0662057C01	RES. CHIP 0 5% 80X50 (NNTN4563B only)
R264	0662057C01	RES. CHIP 0 5% 80X50 (NNTN4563B only)
R301	0662057M67	RES. CHIP 510 5% 20X40
R303	0662057M98	RES. CHIP 10K 5% 20X40
R304	0662057N39	RES. CHIP 470K 5% 20X40
R305	0662057N39	RES. CHIP 470K 5% 20X40
R307	0662057M98	RES. CHIP 10K 5% 20X40
R308	0662057M01	RES. CHIP 0 5% 20X40
R309	0662057M98	RES. CHIP 10K 5% 20X40
R310	0662057M78	RES. CHIP 1500 5% 20X40
R311	0662057M01	RES. CHIP 0 5% 20X40

Ref Des	Part #	Description
R312	0662057N47	RES. CHIP 1.0 MEG 5% 20X40
R313	0662057N47	RES. CHIP 1.0 MEG 5% 20X40
R315	0662057M01	RES. CHIP 0 5% 20X40
R316	0662057M01	RES. CHIP 0 5% 20X40
R317	0662057M01	RES. CHIP 0 5% 20X40
R318	0662057M01	RES. CHIP 0 5% 20X40
R319	0662057M01	RES. CHIP 0 5% 20X40
R321	0662057M98	RES. CHIP 10K 5% 20X40
R325	0662057M98	RES. CHIP 10K 5% 20X40
R326	0662057M98	RES. CHIP 10K 5% 20X40
R327	0662057N23	RES. CHIP 100K 5% 20X40
R328	0662057M01	RES. CHIP 0 5% 20X40
R329	0662057M01	RES. CHIP 0 5% 20X40
R331	0662057M50	RES. CHIP 100 5% 20X40
R334	0662057M01	RES. CHIP 0 5% 20X40
R401	0662057M90	RES. CHIP 4700 5% 20X40
R402	0662057M01	RES. CHIP 0 5% 20X40
R403	0662057M01	RES. CHIP 0 5% 20X40
R404	0662057M01	RES. CHIP 0 5% 20X40
R405	0662057M01	RES. CHIP 0 5% 20X40
R406	0662057M01	RES. CHIP 0 5% 20X40
R413	0662057M01	RES. CHIP 0 5% 20X40
R414	0662057M98	RES. CHIP 10K 5% 20X40
R415	0662057M01	RES. CHIP 0 5% 20X40
R416	0662057M01	RES. CHIP 0 5% 20X40
R417	0662057M01	RES. CHIP 0 5% 20X40
R418	0662057M01	RES. CHIP 0 5% 20X40
R427	NOTPLACED	NOTPLACED
R440	NOTPLACED	NOTPLACED
R441	NOTPLACED	NOTPLACED
R442	0662057M01	RES. CHIP 0 5% 20X40

Ref Des	Part #	Description
R443	NOTPLACED	NOTPLACED
R450	0662057N15	RES. CHIP 47K 5% 20X40
R451	0662057M78	RES. CHIP 1500 5% 20X40
R452	0662057M42	RES. CHIP 47 5% 20X40
R453	0662057N11	RES. CHIP 33K 5% 20X40
R454	0662057M64	RES. CHIP 390 5% 20X40
R455	0662057M74	RES. CHIP 1000 5% 20X40
R461	NOTPLACED	NOTPLACED
R501	0662057M01	RES. CHIP 0 5% 20X40
R502	0662057M01	RES. CHIP 0 5% 20X40
R503	0662057M01	RES. CHIP 0 5% 20X40
R504	0662057N06	RES. CHIP 20K 5% 20X40
R505	0662057M98	RES. CHIP 10K 5% 20X40
R510	0662057M98	RES. CHIP 10K 5% 20X40
R511	NOTPLACED	NOTPLACED
R514	0662057N06	RES. CHIP 20K 5% 20X40
R515	0662057N06	RES. CHIP 20K 5% 20X40
R516	0662057M67	RES. CHIP 510 5% 20X40
R519	0662057M98	RES. CHIP 10K 5% 20X40
R520	0662057U84	RES CHIP 2K 1% 1/16W
R522	0662057N15	RES. CHIP 47K 5% 20X40
R523	0662057N15	RES. CHIP 47K 5% 20X40
R524	0662057N17	RES. CHIP 56K 5% 20X40
R525	0662057N11	RES. CHIP 33K 5% 20X40
R526	0662057V02	RES CHIP 10K 1% 1/16W
R527	0662057M74	RES. CHIP 1000 5% 20X40
R528	0662057M74	RES. CHIP 1000 5% 20X40
R531	0662057M64	RES. CHIP 390 5% 20X40
R533	0662057M82	RES. CHIP 2200 5% 20X40
R536	0662057N23	RES. CHIP 100K 5% 20X40
R537	0662057N17 0662057N10	RES. CHIP 56K 5% 20X40 (NNTN4563A) RES. CHIP 30K 5% 20X40 (NNTN4563B)

Ref Des	Part #	Description
R538	0662057M01	RES. CHIP 0 5% 20X40
R539	0662057M01	RES. CHIP 0 5% 20X40
R540	0662057M95	RES. CHIP 7500 5% 20X40
R545	0662057M98	RES. CHIP 10K 5% 20X40
R548	0662057N06	RES. CHIP 20K 5% 20X40
R549	0662057M98 0662057M96	RES. CHIP 10K 5% 20X40 (NNTN4563A) RES. CHIP 8.2K 5% 20X40 (NNTN4563B)
R550	0662057N17 0662057V25	RES. CHIP 56K 5% 20X40 (NNTN4563A) RES. CHIP 82K 5% 20X40 (NNTN4563B)
R551	0662057N06	RES. CHIP 20K 5% 20X40
R553	0662057M98 0662057M96	RES. CHIP 10K 5% 20X40 (NNTN4563A) RES. CHIP 8.2K 5% 20X40 (NNTN4563B)
R554	0662057N17 0662057V25	RES. CHIP 56K 5% 20X40 (NNTN4563A) RES. CHIP 82K 5% 20X40 (NNTN4563B)
R555	0662057M74	RES. CHIP 1000 5% 20X40
R556	0662057N06	RES. CHIP 20K 5% 20X40
R557	0662057M98	RES. CHIP 10K 5% 20X40
R558	0662057M94	RES. CHIP 6800 5% 20X40
R559	0662057M98	RES. CHIP 10K 5% 20X40
R560	0662057M01	RES. CHIP 0 5% 20X40
R561	0662057M74	RES. CHIP 1000 5% 20X40
R563	0662057M64	RES. CHIP 390 5% 20X40
R564	0662057M98	RES. CHIP 10K 5% 20X40
R565	0662057M82	RES. CHIP 2200 5% 20X40
R566	0662057M95	RES. CHIP 7500 5% 20X40
R567	0662057N15	RES. CHIP 47K 5% 20X40
R568	0662057N15	RES. CHIP 47K 5% 20X40
R569	0662057M90	RES. CHIP 4700 5% 20X40
R572	0662057M50	RES. CHIP 100 5% 20X40
R573	0662057N23	RES. CHIP 100K 5% 20X40

Ref Des	Part #	Description
R574	0662057N23	RES. CHIP 100K 5% 20X40
R575	0662057M98	RES. CHIP 10K 5% 20X40
R576	0662057N23	RES. CHIP 100K 5% 20X40
R577	0662057N15	RES. CHIP 47K 5% 20X40
R578	0662057N15	RES. CHIP 47K 5% 20X40
R579	NOTPLACED	NOTPLACED
R580	NOTPLACED	NOTPLACED
R581	0662057M01	RES. CHIP 0 5% 20X40
R582	0662057M90	RES. CHIP 4700 5% 20X40
R583	0662057M90	RES. CHIP 4700 5% 20X40
R584	0662057M98	RES. CHIP 10K 5% 20X40
R585	0662057M98	RES. CHIP 10K 5% 20X40
R586	0662057N39	RES. CHIP 470K 5% 20X40
R587	0662057M34	RES. CHIP 22 5% 20X40
R588	0662057M34	RES. CHIP 22 5% 20X40
R589	0662057M98	RES. CHIP 10K 5% 20X40
R590	NOTPLACED	NOTPLACED
R591	NOTPLACED	NOTPLACED
R595	0662057B47	RES. CHIP 0 5% 30X60 (NNTN4563B only)
S101	NOTPLACED	NOTPLACED
SCKA	NOTPLACED	NOTPLACED
SCKB	NOTPLACED	NOTPLACED
SH101	2685462E01	SHEILD PATRIOT
SH102	2685665E01	SHEILD FLIPPER
TCK	NOTPLACED	NOTPLACED
TDI	NOTPLACED	NOTPLACED
TDO	NOTPLACED	NOTPLACED
TMS	NOTPLACED	NOTPLACED
TP201	NOTPLACED	NOTPLACED
TP202	NOTPLACED	NOTPLACED
TP206	NOTPLACED	NOTPLACED
TP207	NOTPLACED	NOTPLACED

Ref Des	Part #	Description
TP208	NOTPLACED	NOTPLACED
TP209	NOTPLACED	NOTPLACED
TP210	NOTPLACED	NOTPLACED
TP211	NOTPLACED	NOTPLACED
TP212	NOTPLACED	NOTPLACED
TP213	NOTPLACED	NOTPLACED
TP214	NOTPLACED	NOTPLACED
TP215	NOTPLACED	NOTPLACED
TRST	NOTPLACED	NOTPLACED
U201	5109731C15	IC OP AMP SNGL OPA237 SOT23
U202	5109731C15	IC OP AMP SNGL OPA237 SOT23
U301	5185368C66	IC CUSTOM FLIPPER
U302	5105492X92	IC CMOS BILATERAL SWITCH
U303	5109522E53	IC SNGL BUF NC7S125P5X SC70
U401	5109841C69	IC 256 BGA 17X17 PACKAGE PATRIOT
U402	5199485A01	IC FLASH 8MBYTE BURST BGA
U403	5185368C82	IC 1.65 TO 2.2V, 70NS, 8MBIT SRAM
U404	5109522E53	IC SNGL BUF NC7S125P5X SC70
U405	5109522E53	IC SNGL BUF NC7S125P5X SC70
U406	5105492X03	IC SNG HI SPD L-MOS NOT GATE
U407	5105109Z31	IC QUAD 2:1 MUX/DEMUX
U501	5109879E58	IC 4.3 GCAPII SN104616DGGMR BG
U502	5109731C15	IC OP AMP SNGL OPA237 SOT23
U503	5102463J44	IC AUDIO PA (PHILIPS_20PIN)



Ref Des	Part #	Description
U504	5109731C15	IC OP AMP SNGL OPA237 SOT23
U505	5185353D13	IC MINI SO-8 HI PRECISION REG 5V
U507	5109731C15	IC OP AMP SNGL OPA237 SOT23
U509	5185353D35	IC DUAL EEPOT 256 TAP
U510	5105492X92	IC CMOS BILATERAL SWITCH
U511	5185353D56	IC 3.3V LINEAR REGULATOR MC78LC 33NTR
U512	NOTPLACED	NOTPLACED
VR201	4813832C72	TRANS SUP QUAD 12V
VR202	4813830A22	DIODE 9.1V 5% 225MW MMBZ5239B_
VR203	4813832C72	TRANS SUP QUAD 12V
VR204	4813830C26	DIODE 13V 'H3' MMSZ5243BT1
VR205	4805656W08	DIODE ZENER QUAD
VR206	4805656W08	DIODE ZENER QUAD
VR209	4813832C72	TRANS SUP QUAD 12V
VR220	4805656W03	DIODE DUAL 5.6V ZENER
VR221	4805656W03	DIODE DUAL 5.6V ZENER
VR501	4813830A15	DIODE 5.6V 5% 225MW MMBZ5232B_
Y301	4809995L05	XTAL QUARTZ 32.768KHZ CC4V-T1



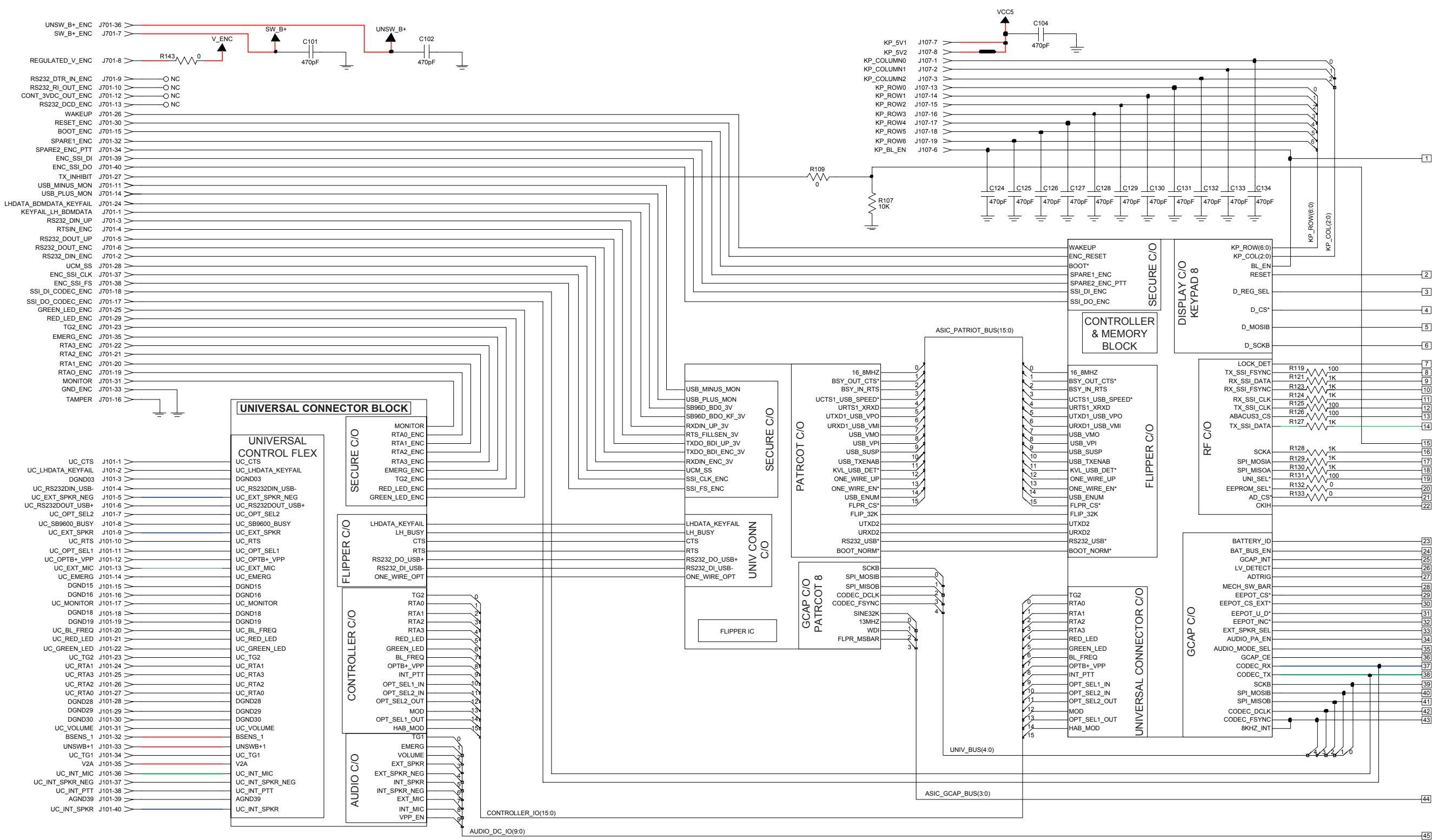

63B81096C91-O  
Sheet 1 of 2

Figure 8-88. NNTN4819A VOCON Board Overall Schematic—Sheet 1 of 2



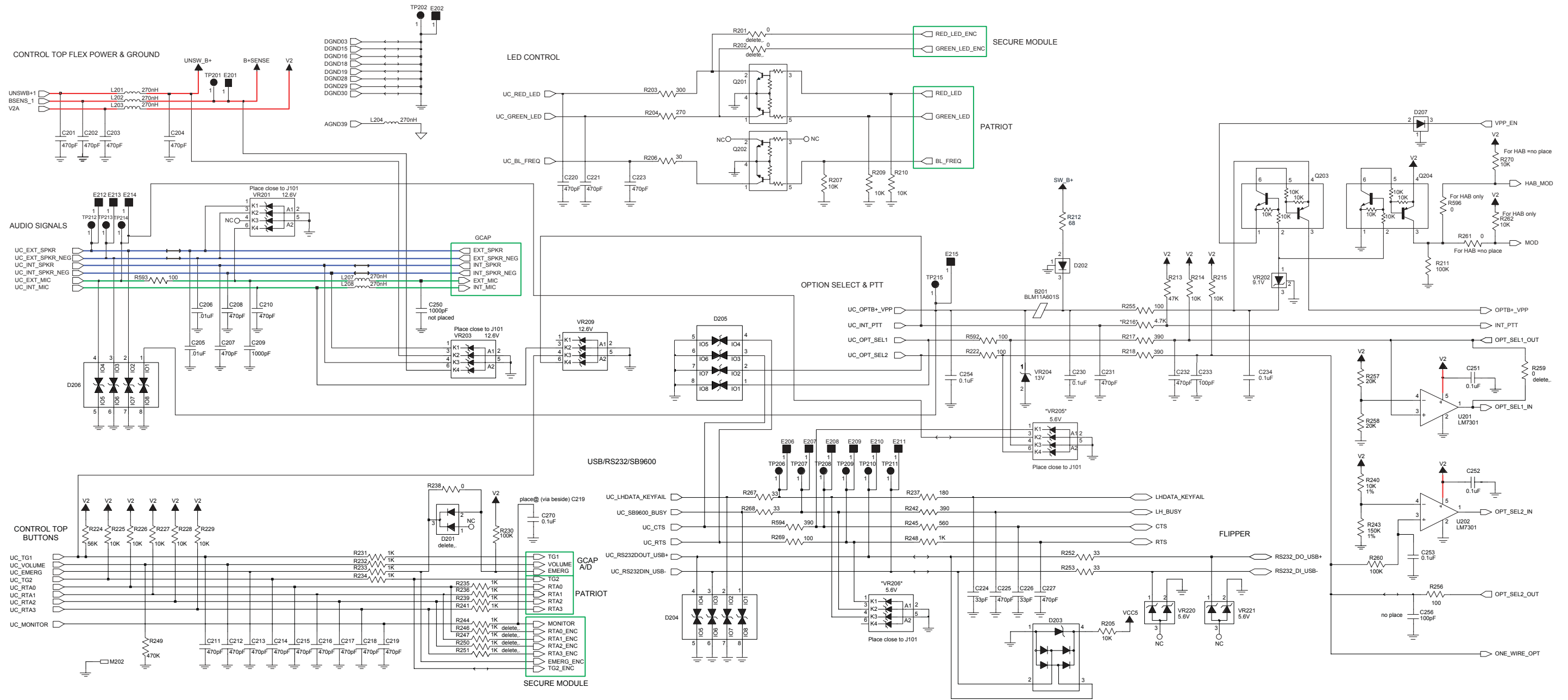

63B81096C92-O

Figure 8-90. NNTN4819A VOCON Universal Connector and ESD Circuits

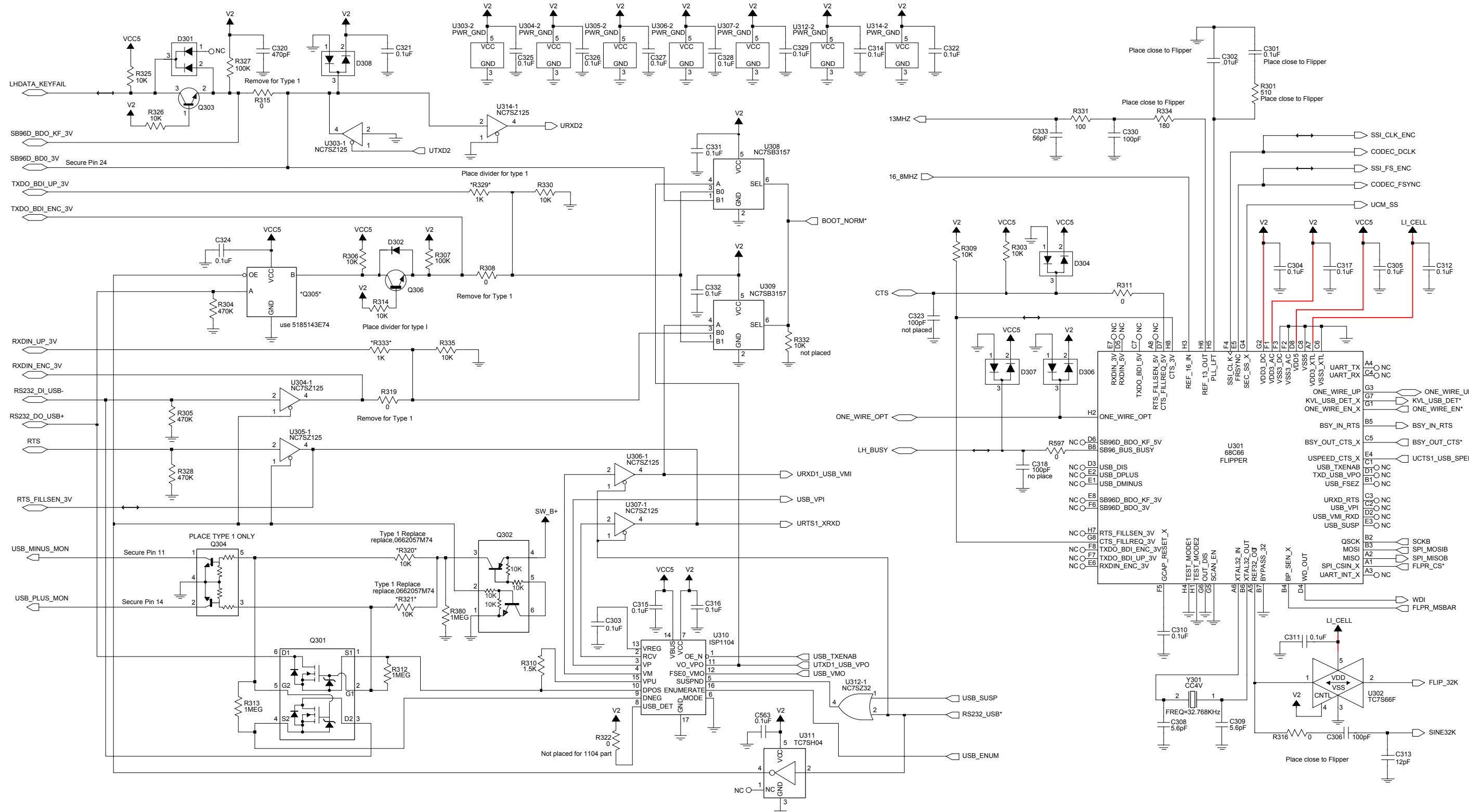

Figure 8-91. NNTN4819A VOCON Flipper Circuit

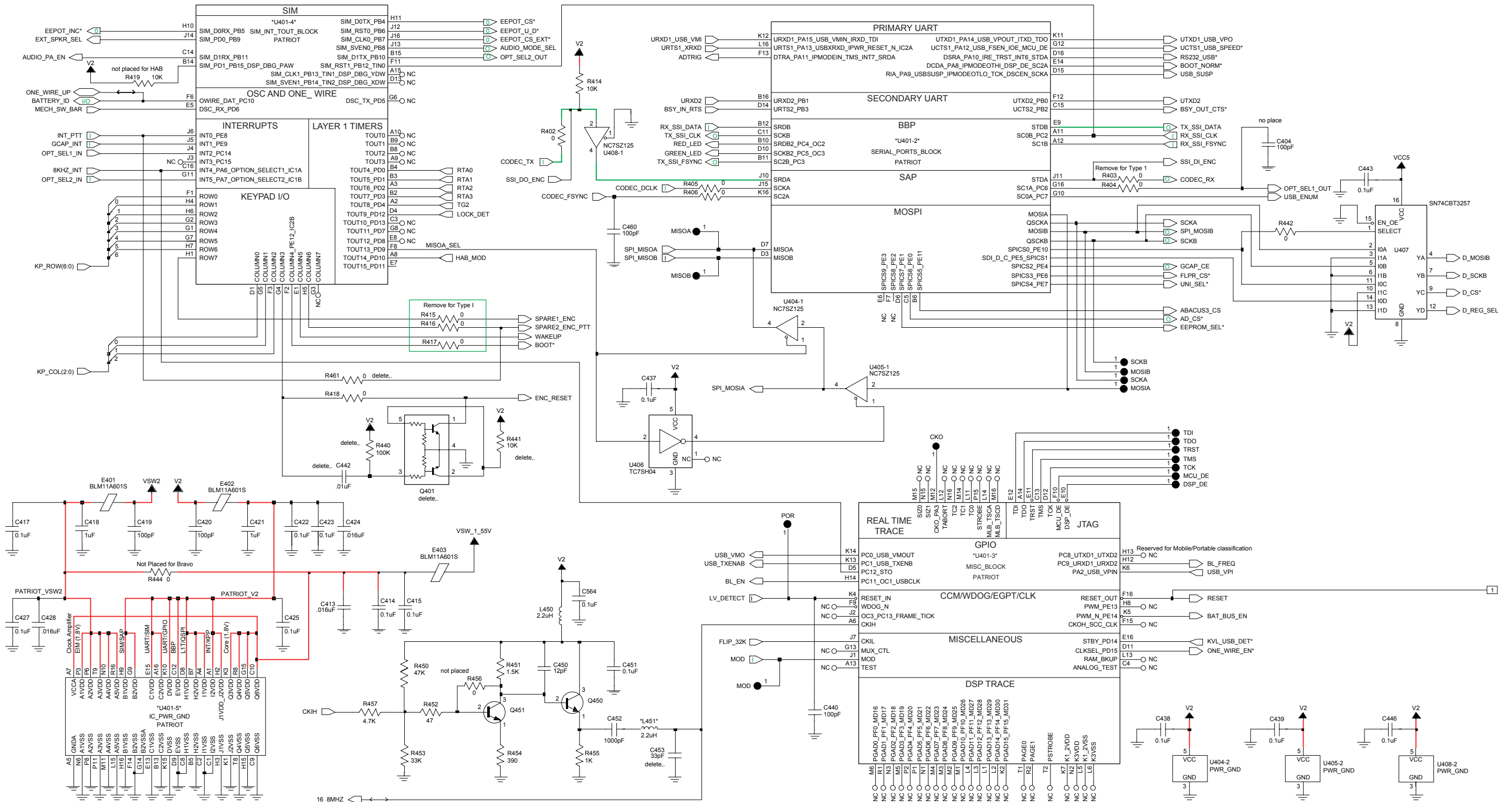
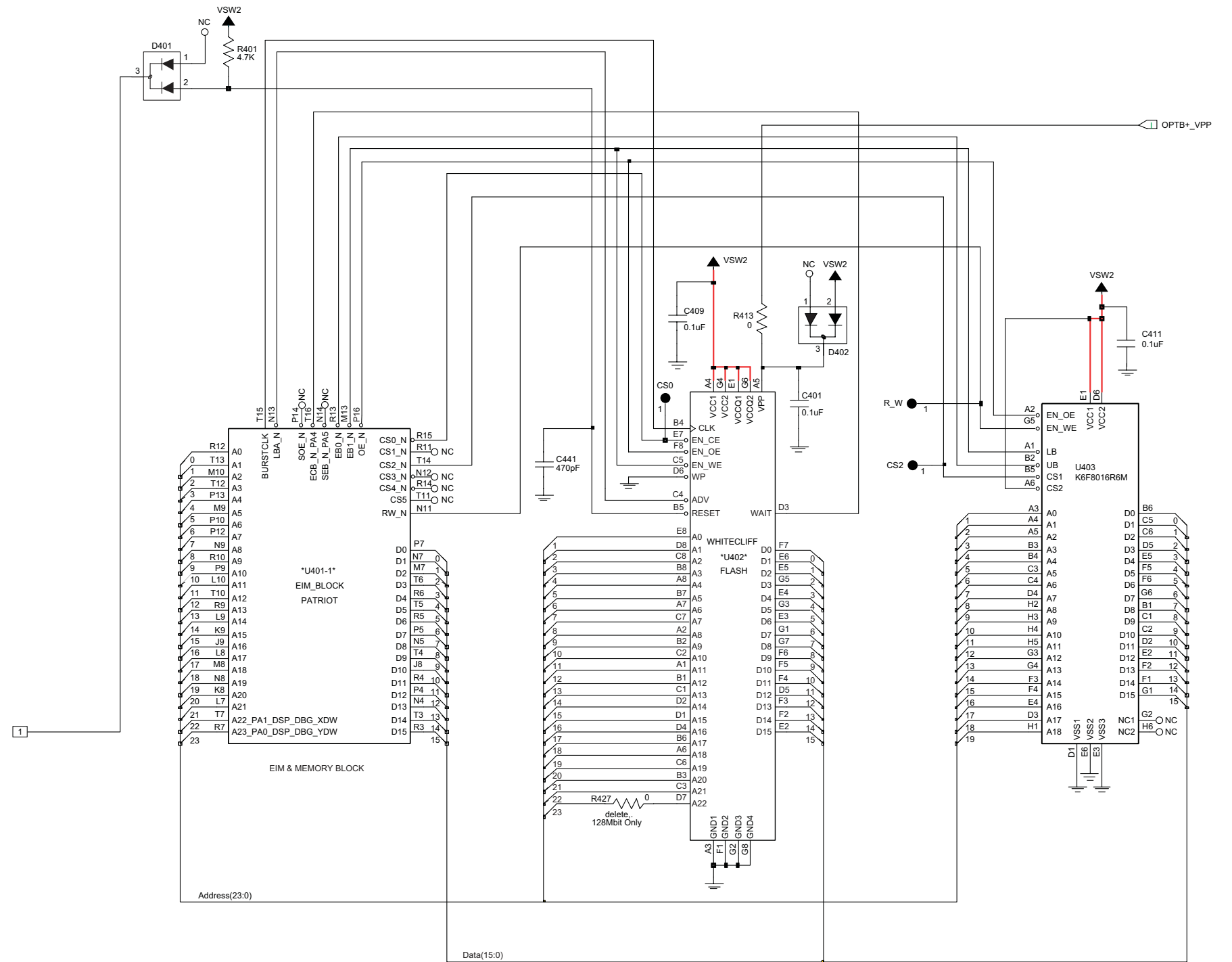

Figure 8-92. NNTN4819A VOCON Controller and Memory Circuits—Sheet 1 of 2



63B81096C94-O  
Sheet 2 of 2

Figure 8-93. NNTN4819A VOCON Controller and Memory Circuits—Sheet 2 of 2



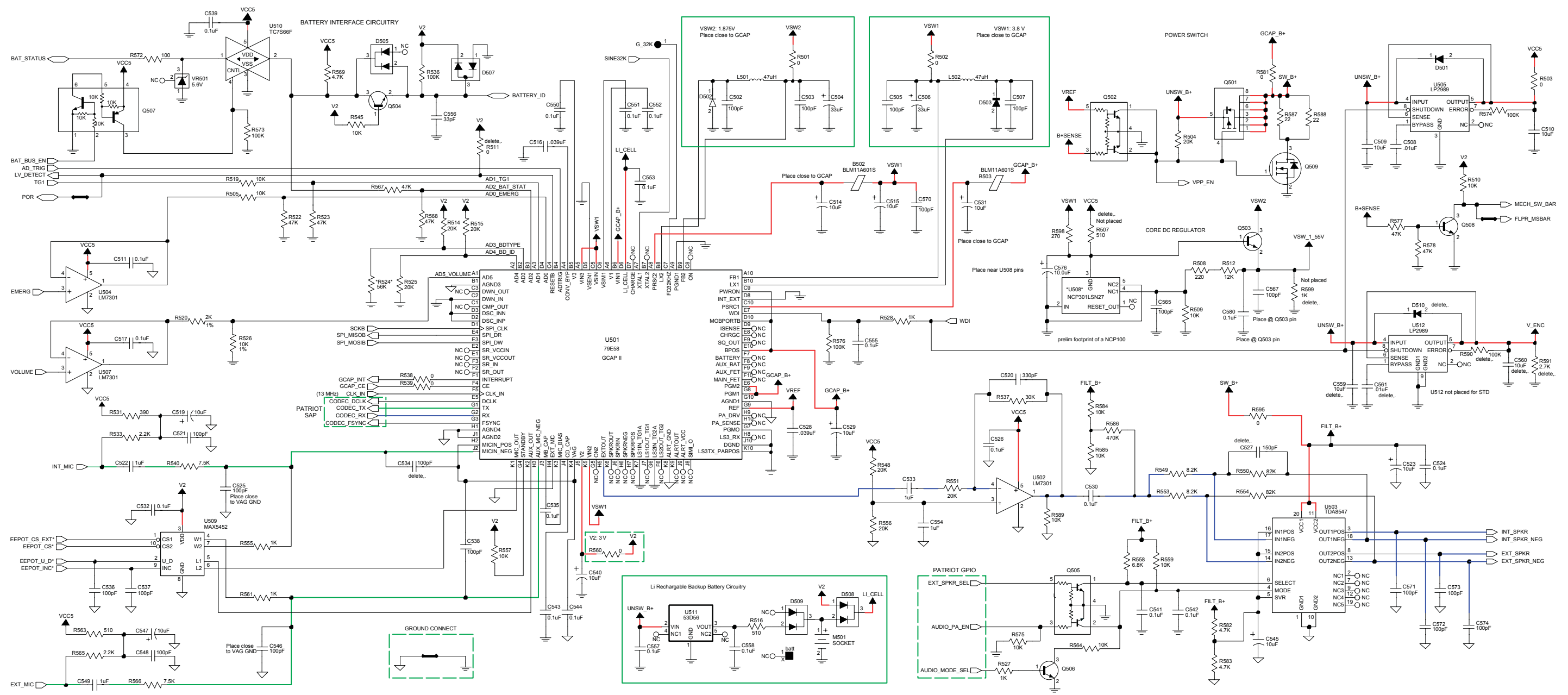

63B81096C95-0

Figure 8-94. NNTN4819A VOCON Audio/DC Circuits





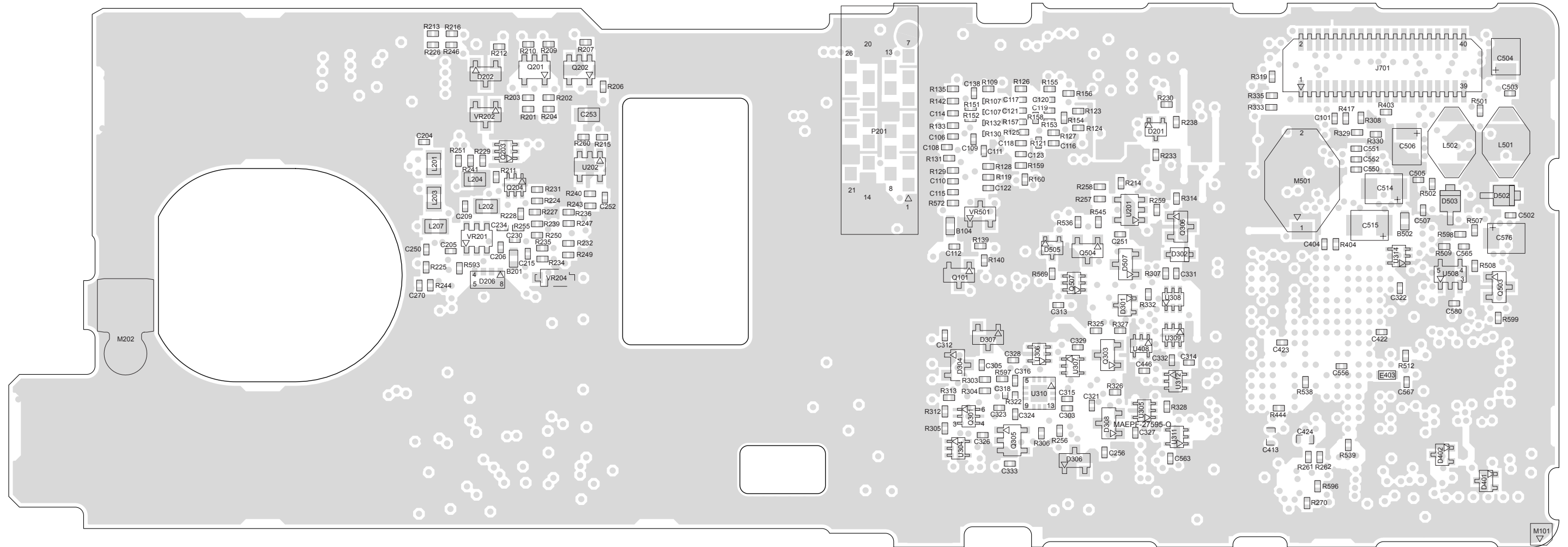

MAEPF-27596-O

Figure 8-96. NNTN4819A VOCON Board Layout—Side 2

## NNTN4819A VOCON Board Parts List

Ref. Des.	Part Number	Description
B101	2480574F01	IND FERRITE CHIP 600 OHM 0603
B104	2462586G33	INDUCTOR CHIP FERRITE BEADS
B201	2480574F01	IND FERRITE CHIP 600 OHM 0603
B502	2480574F01	IND FERRITE CHIP 600 OHM 0603
B503	2480574F01	IND FERRITE CHIP 600 OHM 0603
BATT	6003710K08	BATT COIN 3.3V LIION
C101	2113743L09	CAP CHIP 470 PF 10% X7R
C102	2113743L09	CAP CHIP 470 PF 10% X7R
C103	2113743L09	CAP CHIP 470 PF 10% X7R
C104	2113743L09	CAP CHIP 470 PF 10% X7R
C106	2113743L09	CAP CHIP 470 PF 10% X7R
C107	2113743L09	CAP CHIP 470 PF 10% X7R
C108	2113743L09	CAP CHIP 470 PF 10% X7R
C109	2113743N38	CAP CHIP 33.0 PF 5% COG
C110	2113743N38	CAP CHIP 33.0 PF 5% COG
C111	2113743N38	CAP CHIP 33.0 PF 5% COG
C112	2113743N50	CAP CHIP 100 PF 5% COG
C113	2113743L09	CAP CHIP 470 PF 10% X7R
C114	2113743L09	CAP CHIP 470 PF 10% X7R
C115	2113743L09	CAP CHIP 470 PF 10% X7R
C116	2113743N38	CAP CHIP 33.0 PF 5% COG
C117	2113743L09	CAP CHIP 470 PF 10% X7R
C118	2113743N38	CAP CHIP 33.0 PF 5% COG
C119	2113743N38	CAP CHIP 33.0 PF 5% COG
C120	2113743N38	CAP CHIP 33.0 PF 5% COG
C121	2113743N38	CAP CHIP 33.0 PF 5% COG
C122	2113743N38	CAP CHIP 33.0 PF 5% COG
C123	2113743L09	CAP CHIP 470 PF 10% X7R
C124	2113743L09	CAP CHIP 470 PF 10% X7R
C125	2113743L09	CAP CHIP 470 PF 10% X7R
C126	2113743L09	CAP CHIP 470 PF 10% X7R
C127	2113743L09	CAP CHIP 470 PF 10% X7R
C128	2113743L09	CAP CHIP 470 PF 10% X7R
C129	2113743L09	CAP CHIP 470 PF 10% X7R

Ref. Des.	Part Number	Description
C130	2113743L09	CAP CHIP 470 PF 10% X7R
C131	2113743L09	CAP CHIP 470 PF 10% X7R
C132	2113743L09	CAP CHIP 470 PF 10% X7R
C133	2113743L09	CAP CHIP 470 PF 10% X7R
C134	2113743L09	CAP CHIP 470 PF 10% X7R
C135	2113743L41	CAP CHIP 10000 PF 10% X7R
C136	2113743L09	CAP CHIP 470 PF 10% X7R
C137	2113743A31	CAP CHIP 1.0UF 10% X7R
C138	2113743L09	CAP CHIP 470 PF 10% X7R
C170	2113743M24	CAP CHIP 100000 PF +80-20% Y5V
C171	2113743M24	CAP CHIP 100000 PF +80-20% Y5V
C172	NOTPLACED	NOTPLACED
C201	2113743L09	CAP CHIP 470 PF 10% X7R
C202	2113743L09	CAP CHIP 470 PF 10% X7R
C203	2113743L09	CAP CHIP 470 PF 10% X7R
C204	2113743L09	CAP CHIP 470 PF 10% X7R
C205	2113743L41	CAP CHIP 10000 PF 10% X7R
C206	2113743L41	CAP CHIP 10000 PF 10% X7R
C207	2113743L09	CAP CHIP 470 PF 10% X7R
C208	2113743L09	CAP CHIP 470 PF 10% X7R
C209	2113743L17	CAP CHIP 1000 PF 10% X7R
C210	2113743L09	CAP CHIP 470 PF 10% X7R
C211	2113743L09	CAP CHIP 470 PF 10% X7R
C212	2113743L09	CAP CHIP 470 PF 10% X7R
C213	2113743L09	CAP CHIP 470 PF 10% X7R
C214	2113743L09	CAP CHIP 470 PF 10% X7R
C215	2113743L09	CAP CHIP 470 PF 10% X7R
C216	2113743L09	CAP CHIP 470 PF 10% X7R
C217	2113743L09	CAP CHIP 470 PF 10% X7R
C218	2113743L09	CAP CHIP 470 PF 10% X7R
C219	2113743L09	CAP CHIP 470 PF 10% X7R
C220	2113743L09	CAP CHIP 470 PF 10% X7R
C221	2113743L09	CAP CHIP 470 PF 10% X7R
C223	2113743L09	CAP CHIP 470 PF 10% X7R
C224	2113743N38	CAP CHIP 33.0 PF 5% COG

Ref. Des.	Part Number	Description
C225	2113743L09	CAP CHIP 470 PF 10% X7R
C226	2113743N38	CAP CHIP 33.0 PF 5% COG
C227	2113743L09	CAP CHIP 470 PF 10% X7R
C230	2113743M24	CAP CHIP 100000 PF +80-20% Y5V
C231	2113743L09	CAP CHIP 470 PF 10% X7R
C232	2113743L09	CAP CHIP 470 PF 10% X7R
C233	2113743N50	CAP CHIP 100 PF 5% COG
C234	2113743M24	CAP CHIP 100000 PF +80-20% Y5V
C250	NOTPLACED	NOTPLACED
C251	2113743M24	CAP CHIP 100000 PF +80-20% Y5V
C252	2113743M24	CAP CHIP 100000 PF +80-20% Y5V
C253	2113743A19	CAP CHIP .100 UF 10% X7R
C254	2113743M24	CAP CHIP 100000 PF +80-20% Y5V
C256	NOTPLACED	NOTPLACED
C270	2113743M24	CAP CHIP 100000 PF +80-20% Y5V
C301	2113743E20	CAP CHIP .10 UF 10%
C302	2113743L41	CAP CHIP 10000 PF 10% X7R
C303	2113743M24	CAP CHIP 100000 PF +80-20% Y5V
C304	2113743M24	CAP CHIP 100000 PF +80-20% Y5V
C305	2113743M24	CAP CHIP 100000 PF +80-20% Y5V
C306	2113743N50	CAP CHIP 100 PF 5% COG
C308	2113743N20	CAP CHIP 5.6PF +/-5PF COG
C309	2113743N20	CAP CHIP 5.6PF +/-5PF COG
C310	2113743M24	CAP CHIP 100000 PF +80-20% Y5V
C311	2113743M24	CAP CHIP 100000 PF +80-20% Y5V
C312	2113743M24	CAP CHIP 100000 PF +80-20% Y5V
C313	2113743N28	CAP CHIP 12.0 PF 5% COG

Ref. Des.	Part Number	Description
C314	2113743M24	CAP CHIP 100000 PF +80-20% Y5V
C315	2113743M24	CAP CHIP 100000 PF +80-20% Y5V
C316	2113743M24	CAP CHIP 100000 PF +80-20% Y5V
C317	2113743M24	CAP CHIP 100000 PF +80-20% Y5V
C318	NOTPLACED	NOTPLACED
C320	2113743L09	CAP CHIP 470 PF 10% X7R
C321	2113743M24	CAP CHIP 100000 PF +80-20% Y5V
C322	2113743M24	CAP CHIP 100000 PF +80-20% Y5V
C323	NOTPLACED	NOTPLACED
C324	2113743M24	CAP CHIP 100000 PF +80-20% Y5V
C325	2113743M24	CAP CHIP 100000 PF +80-20% Y5V
C326	2113743M24	CAP CHIP 100000 PF +80-20% Y5V
C327	2113743M24	CAP CHIP 100000 PF +80-20% Y5V
C328	2113743M24	CAP CHIP 100000 PF +80-20% Y5V
C329	2113743M24	CAP CHIP 100000 PF +80-20% Y5V
C330	2113743N50	CAP CHIP 100 PF 5% COG
C331	2113743M24	CAP CHIP 100000 PF +80-20% Y5V
C332	2113743M24	CAP CHIP 100000 PF +80-20% Y5V
C333	2113743N44	CAP CHIP 56.0 PF 5% COG
C401	2113743M24	CAP CHIP 100000 PF +80-20% Y5V
C404	NOTPLACED	NOTPLACED
C409	2113743M24	CAP CHIP 100000 PF +80-20% Y5V
C411	2113743M24	CAP CHIP 100000 PF +80-20% Y5V
C413	2113743E04	CAP CER CHIP .016UF
C414	2113743M24	CAP CHIP 100000 PF +80-20% Y5V
C415	2113743M24	CAP CHIP 100000 PF +80-20% Y5V

Ref. Des.	Part Number	Description
C417	2113743M24	CAP CHIP 100000 PF +80-20% Y5V
C418	2113743A31	CAP CHIP 1.0UF 10% X7R
C419	2113743N50	CAP CHIP 100 PF 5% COG
C420	2113743N50	CAP CHIP 100 PF 5% COG
C421	2113743A31	CAP CHIP 1.0UF 10% X7R
C422	2113743M24	CAP CHIP 100000 PF +80-20% Y5V
C423	2113743M24	CAP CHIP 100000 PF +80-20% Y5V
C424	2113743E04	CAP CER CHIP .016UF
C425	2113743M24	CAP CHIP 100000 PF +80-20% Y5V
C427	2113743M24	CAP CHIP 100000 PF +80-20% Y5V
C428	2113743E04	CAP CER CHIP .016UF
C437	2113743M24	CAP CHIP 100000 PF +80-20% Y5V
C438	2113743M24	CAP CHIP 100000 PF +80-20% Y5V
C439	2113743M24	CAP CHIP 100000 PF +80-20% Y5V
C440	2113743N50	CAP CHIP 100 PF 5% COG
C441	2113743L09	CAP CHIP 470 PF 10% X7R
C442	NOTPLACED	NOTPLACED
C443	2113743M24	CAP CHIP 100000 PF +80-20% Y5V
C446	2113743M24	CAP CHIP 100000 PF +80-20% Y5V
C450	2113743N28	CAP CHIP 12.0 PF 5% COG
C451	2113743E20	CAP CHIP .10 UF 10%
C452	2113743L17	CAP CHIP 1000 PF 10% X7R
C453	NOTPLACED	NOTPLACED
C460	NOTPLACED	NOTPLACED
C502	2113743N50	CAP CHIP 100 PF 5% COG
C503	2113743N50	CAP CHIP 100 PF 5% COG
C504	2311049C52	CAP TANT CHIP 33UF 10% 10V
C505	2113743N50	CAP CHIP 100 PF 5% COG
C506	2311049C52	CAP TANT CHIP 33UF 10% 10V
C507	2113743N50	CAP CHIP 100 PF 5% COG

Ref. Des.	Part Number	Description
C508	2113743L41	CAP CHIP 10000 PF 10% X7R
C509	2113743T19	CAP 10UF 16V CER 3225 X5R
C510	2113743T19	CAP 10UF 16V CER 3225 X5R
C511	2113743M24	CAP CHIP 100000 PF +80-20% Y5V
C514	2311049A57	CAP TANT CHIP A/P 10UF 10% 16V
C515	2311049A57	CAP TANT CHIP A/P 10UF 10% 16V
C516	2113743E11	CAP CHIP .039 UF 10% X7R
C517	2113743M24	CAP CHIP 100000 PF +80-20% Y5V
C519	2311049A57	CAP TANT CHIP A/P 10UF 10% 16V
C520	2113743L05	CAP CHIP 330 PF 10% X7R
C521	2113743N50	CAP CHIP 100 PF 5% COG
C522	2113743A31	CAP CHIP 1.0UF 10% X7R
C523	2311049A57	CAP TANT CHIP A/P 10UF 10% 16V
C524	2113743M24	CAP CHIP 100000 PF +80-20% Y5V
C525	2113743N50	CAP CHIP 100 PF 5% COG
C526	2113743M24	CAP CHIP 100000 PF +80-20% Y5V
C527	NOTPLACED	NOTPLACED
C528	2113743E11	CAP CHIP .039 UF 10% X7R
C529	2311049A57	CAP TANT CHIP A/P 10UF 10% 16V
C530	2113743A19	CAP CHIP .100 UF 10% X7R
C531	2311049A57	CAP TANT CHIP A/P 10UF 10% 16V
C532	2113743M24	CAP CHIP 100000 PF +80-20% Y5V
C533	2113743A31	CAP CHIP 1.0UF 10% X7R
C534	NOTPLACED	NOTPLACED
C535	2113743M24	CAP CHIP 100000 PF +80-20% Y5V
C536	2113743N50	CAP CHIP 100 PF 5% COG

Ref. Des.	Part Number	Description
C537	2113743N50	CAP CHIP 100 PF 5% COG
C538	2113743N50	CAP CHIP 100 PF 5% COG
C539	2113743M24	CAP CHIP 100000 PF +80-20% Y5V
C540	2311049A57	CAP TANT CHIP A/P 10UF 10% 16V
C541	2113743M24	CAP CHIP 100000 PF +80-20% Y5V
C542	2113743M24	CAP CHIP 100000 PF +80-20% Y5V
C543	2113743M24	CAP CHIP 100000 PF +80-20% Y5V
C544	2113743M24	CAP CHIP 100000 PF +80-20% Y5V
C545	2311049A57	CAP TANT CHIP A/P 10UF 10% 16V
C546	2113743N50	CAP CHIP 100 PF 5% COG
C547	2311049A57	CAP TANT CHIP A/P 10UF 10% 16V
C548	2113743N50	CAP CHIP 100 PF 5% COG
C549	2113743A31	CAP CHIP 1.0UF 10% X7R
C550	2113743M24	CAP CHIP 100000 PF +80-20% Y5V
C551	2113743M24	CAP CHIP 100000 PF +80-20% Y5V
C552	2113743M24	CAP CHIP 100000 PF +80-20% Y5V
C553	2113743M24	CAP CHIP 100000 PF +80-20% Y5V
C554	2113743A31	CAP CHIP 1.0UF 10% X7R
C555	2113743M24	CAP CHIP 100000 PF +80-20% Y5V
C556	2113743N38	CAP CHIP 33.0 PF 5% COG
C557	2113743M24	CAP CHIP 100000 PF +80-20% Y5V
C558	2113743M24	CAP CHIP 100000 PF +80-20% Y5V
C559	NOTPLACED	NOTPLACED
C560	NOTPLACED	NOTPLACED
C561	NOTPLACED	NOTPLACED
C563	2113743M24	CAP CHIP 100000 PF +80-20% Y5V
C564	2113743M24	CAP CHIP 100000 PF +80-20% Y5V

Ref. Des.	Part Number	Description
C565	NOTPLACED	NOTPLACED
C567	NOTPLACED	NOTPLACED
C570	2113743N50	CAP CHIP 100 PF 5% COG
C571	2113743N50	CAP CHIP 100 PF 5% COG
C572	2113743N50	CAP CHIP 100 PF 5% COG
C573	2113743N50	CAP CHIP 100 PF 5% COG
C574	2113743N50	CAP CHIP 100 PF 5% COG
C576	NOTPLACED	NOTPLACED
C580	NOTPLACED	NOTPLACED
D201	NOTPLACED	NOTPLACED
D202	4805129M90	DIODE SOT PKGD
D203	4802021P15	ZENER SR05
D204	4805656W39	QUAD ESD SUPPRESSOR ARRAY -41206ESDA
D205	4805656W39	QUAD ESD SUPPRESSOR ARRAY -41206ESDA
D206	4805656W39	QUAD ESD SUPPRESSOR ARRAY -41206ESDA
D207	4805129M90	DIODE SOT PKGD
D301	4805218N57	DIODE DUAL
D302	4805656W37	TSTR BAT54HT1
D304	4805129M06	DIODE MMBD7000
D306	4805129M06	DIODE MMBD7000
D307	4805129M06	DIODE MMBD7000
D308	4805129M06	DIODE MMBD7000
D401	4805218N57	DIODE DUAL
D402	4805218N57	DIODE DUAL
D501	4813833A20	DIODE SCHOTTKY 1A 40V PWRMITE
D502	4813833A20	DIODE SCHOTTKY 1A 40V PWRMITE
D503	4813833A20	DIODE SCHOTTKY 1A 40V PWRMITE
D505	4805218N57	DIODE DUAL
D507	4805129M06	DIODE MMBD7000
D508	4805218N57	DIODE DUAL
D509	4805218N57	DIODE DUAL
D510	NOTPLACED	NOTPLACED
E401	2480574F01	IND FERRITE CHIP 600 OHM 0603

Ref. Des.	Part Number	Description
E402	2480574F01	IND FERRITE CHIP 600 OHM 0603
E403	NOTPLACED	NOTPLACED
J101	0985185D01	CONN RECEPT 0.5MM PITCH 40 CKTS
J107	0987817K01	RECP BTB 0.5P 1.5 STACK SMD
J301	0987817K01	RECP BTB 0.5P 1.5 STACK SMD
J701	0980423L02	40PIN ROBIN CONN 3MM
L101	2404574Z14	IND CHIP WW 270NH 2% 2012 SMD
L201	2404574Z14	IND CHIP WW 270NH 2% 2012 SMD
L202	2404574Z14	IND CHIP WW 270NH 2% 2012 SMD
L203	2404574Z14	IND CHIP WW 270NH 2% 2012 SMD
L204	2404574Z14	IND CHIP WW 270NH 2% 2012 SMD
L207	2404574Z14	IND CHIP WW 270NH 2% 2012 SMD
L208	2404574Z14	IND CHIP WW 270NH 2% 2012 SMD
L450	2462587Q20	IND CHIP 2,200 NH 20%
L451	0662057C01	CHIP RES 0 OHMS +.050 OHMS
L501	2486085A06	COIL 47UH SMT POWER INDUCTOR
L502	2486085A06	COIL 47UH SMT POWER INDUCTOR
M202	3985951A01	CONTACT ANTENNA GROUND
M501	0985888K02	SKT RTC BTTY LEAP
PCB	8485871E03	PCB XTS5000
Q101	4813824A10	TSTR NPN 40V .2A GEN PURP
Q201	4805921T09	XSTR DUAL ROHM FMG8
Q202	4805921T09	XSTR DUAL ROHM FMG8
Q203	4805723X03	TRANS DUAL NPN-PNP UMD3N ROHM
Q204	4805723X03	TRANS DUAL NPN-PNP UMD3N ROHM
Q301	4809579E35	TSTR FET DUAL N-CHAN FDG3601N

Ref. Des.	Part Number	Description
Q302	4805723X03	TRANS DUAL NPN-PNP UMD3N ROHM
Q303	4813824A10	TSTR NPN 40V .2A GEN PURP
Q304	NOTPLACED	NOTPLACED
Q305	5185143E74	IC SINGLE FET BUS SWITCH
Q306	4813824A10	TSTR NPN 40V .2A GEN PURP
Q401	NOTPLACED	NOTPLACED
Q450	4805793Y01	TRANS MINI SOT NPN LOW NOISE
Q451	4805793Y01	TRANS MINI SOT NPN LOW NOISE
Q501	4885844C01	XSTR FET
Q502	4805921T09	XSTR DUAL ROHM FMG8
Q503	NOTPLACED	NOTPLACED
Q504	4813824A10	TSTR NPN 40V .2A GEN PURP
Q505	4805921T09	XSTR DUAL ROHM FMG8
Q506	4813824A10	TSTR NPN 40V .2A GEN PURP
Q507	4805723X03	TRANS DUAL NPN-PNP UMD3N ROHM
Q508	4813824A10	TSTR NPN 40V .2A GEN PURP
Q509	4805218N11	XISTOR SOT RH BST82
R103	0662057M56	RES. CHIP 180 5% 20X40
R104	0662057M56	RES. CHIP 180 5% 20X40
R106	0662057M50	RES. CHIP 100 5% 20X40
R107	0662057M98	RES. CHIP 10K 5% 20X40
R109	0662057M01	RES. CHIP 0 5% 20X40
R119	0662057M50	RES. CHIP 100 5% 20X40
R121	0662057M74	RES. CHIP 1000 5% 20X40
R123	0662057M74	RES. CHIP 1000 5% 20X40
R124	0662057M74	RES. CHIP 1000 5% 20X40
R125	0662057M50	RES. CHIP 100 5% 20X40
R126	0662057M50	RES. CHIP 100 5% 20X40
R127	0662057M74	RES. CHIP 1000 5% 20X40
R128	0662057M74	RES. CHIP 1000 5% 20X40
R129	0662057M74	RES. CHIP 1000 5% 20X40
R130	0662057M74	RES. CHIP 1000 5% 20X40

Ref. Des.	Part Number	Description
R131	0662057M50	RES. CHIP 100 5% 20X40
R132	0662057M01	RES. CHIP 0 5% 20X40
R133	0662057M01	RES. CHIP 0 5% 20X40
R135	0662057M74	RES. CHIP 1000 5% 20X40
R138	0662057M98	RES. CHIP 10K 5% 20X40
R139	0662057M98	RES. CHIP 10K 5% 20X40
R140	0662057M90	RES. CHIP 4700 5% 20X40
R141	NOTPLACED	NOTPLACED
R142	0662057M98	RES. CHIP 10K 5% 20X40
R143	0662057M01	RES. CHIP 0 5% 20X40
R151	0662057M01	RES. CHIP 0 5% 20X40
R152	NOTPLACED	NOTPLACED
R153	0662057M01	RES. CHIP 0 5% 20X40
R154	NOTPLACED	NOTPLACED
R155	0662057M01	RES. CHIP 0 5% 20X40
R156	NOTPLACED	NOTPLACED
R157	0662057M01	RES. CHIP 0 5% 20X40
R158	NOTPLACED	NOTPLACED
R159	0662057M01	RES. CHIP 0 5% 20X40
R160	NOTPLACED	NOTPLACED
R201	NOTPLACED	NOTPLACED
R202	NOTPLACED	NOTPLACED
R203	0662057M61	RES. CHIP 300 5% 20X40
R204	0662057M60	RES. CHIP 270 5% 20X40
R206	0662057M37	20X40 30 OMH 5% CHIP RESISTOR
R207	0662057M98	RES. CHIP 10K 5% 20X40
R209	0662057M98	RES. CHIP 10K 5% 20X40
R210	0662057M98	RES. CHIP 10K 5% 20X40
R211	0662057N23	RES. CHIP 100K 5% 20X40
R212	0662057M46	RES. CHIP 68 5% 20X40
R213	0662057N15	RES. CHIP 47K 5% 20X40
R214	0662057M98	RES. CHIP 10K 5% 20X40
R215	0662057M98	RES. CHIP 10K 5% 20X40
R216	0662057M90	RES. CHIP 4700 5% 20X40
R217	0662057M64	RES. CHIP 390 5% 20X40
R218	0662057M64	RES. CHIP 390 5% 20X40
R222	0662057M50	RES. CHIP 100 5% 20X40

Ref. Des.	Part Number	Description
R224	0662057N17	RES. CHIP 56K 5% 20X40
R225	0662057M98	RES. CHIP 10K 5% 20X40
R226	0662057M98	RES. CHIP 10K 5% 20X40
R227	0662057M98	RES. CHIP 10K 5% 20X40
R228	0662057M98	RES. CHIP 10K 5% 20X40
R229	0662057M98	RES. CHIP 10K 5% 20X40
R230	0662057N23	RES. CHIP 100K 5% 20X40
R231	0662057M74	RES. CHIP 1000 5% 20X40
R232	0662057M74	RES. CHIP 1000 5% 20X40
R233	0662057M74	RES. CHIP 1000 5% 20X40
R234	0662057M74	RES. CHIP 1000 5% 20X40
R235	0662057M74	RES. CHIP 1000 5% 20X40
R236	0662057M74	RES. CHIP 1000 5% 20X40
R237	0662057M56	RES. CHIP 180 5% 20X40
R238	0662057M01	RES. CHIP 0 5% 20X40
R239	0662057M74	RES. CHIP 1000 5% 20X40
R240	0662057V02	RES CHIP 10K 1% 1/16W
R241	0662057M74	RES. CHIP 1000 5% 20X40
R242	0662057M64	RES. CHIP 390 5% 20X40
R243	0662057V32	RESISTOR, 150 KOHM, 20X40, 1%
R244	0662057M74	RES. CHIP 1000 5% 20X40
R245	0662057M68	560 OHM TX LOOP FILTER
R246	NOTPLACED	NOTPLACED
R247	NOTPLACED	NOTPLACED
R248	0662057M74	RES. CHIP 1000 5% 20X40
R249	0662057N39	RES. CHIP 470K 5% 20X40
R250	NOTPLACED	NOTPLACED
R251	NOTPLACED	NOTPLACED
R252	0662057M38	RES. CHIP 33 5% 20X40
R253	0662057M38	RES. CHIP 33 5% 20X40
R255	0662057M50	RES. CHIP 100 5% 20X40
R256	0662057M50	RES. CHIP 100 5% 20X40
R257	0662057N06	RES. CHIP 20K 5% 20X40
R258	0662057N06	RES. CHIP 20K 5% 20X40
R259	NOTPLACED	NOTPLACED
R260	0662057N23	RES. CHIP 100K 5% 20X40
R261	0662057M01	RES. CHIP 0 5% 20X40
R262	NOTPLACED	NOTPLACED

Ref. Des.	Part Number	Description
R267	0662057M38	RES. CHIP 33 5% 20X40
R268	0662057M38	RES. CHIP 33 5% 20X40
R269	0662057M50	RES. CHIP 100 5% 20X40
R270	0662057M98	RES. CHIP 10K 5% 20X40
R301	0662057M67	RES. CHIP 510 5% 20X40
R303	0662057M98	RES. CHIP 10K 5% 20X40
R304	0662057N39	RES. CHIP 470K 5% 20X40
R305	0662057N39	RES. CHIP 470K 5% 20X40
R306	0662057M98	RES. CHIP 10K 5% 20X40
R307	0662057N23	RES. CHIP 100K 5% 20X40
R308	0662057M01	RES. CHIP 0 5% 20X40
R309	0662057M98	RES. CHIP 10K 5% 20X40
R310	0662057M78	RES. CHIP 1500 5% 20X40
R311	0662057M01	RES. CHIP 0 5% 20X40
R312	0662057N47	RES. CHIP 1.0 MEG 5% 20X40
R313	0662057N47	RES. CHIP 1.0 MEG 5% 20X40
R314	0662057M98	RES. CHIP 10K 5% 20X40
R315	0662057M01	RES. CHIP 0 5% 20X40
R316	0662057M01	RES. CHIP 0 5% 20X40
R319	0662057M01	RES. CHIP 0 5% 20X40
R320	0662057M98	RES. CHIP 10K 5% 20X40
R321	0662057M98	RES. CHIP 10K 5% 20X40
R322	NOTPLACED	NOTPLACED
R325	0662057M98	RES. CHIP 10K 5% 20X40
R326	0662057M98	RES. CHIP 10K 5% 20X40
R327	0662057N23	RES. CHIP 100K 5% 20X40
R328	0662057N39	RES. CHIP 470K 5% 20X40
R329	NOTPLACED	NOTPLACED
R330	NOTPLACED	NOTPLACED
R331	0662057M50	RES. CHIP 100 5% 20X40
R332	NOTPLACED	NOTPLACED
R333	NOTPLACED	NOTPLACED
R334	0662057M56	RES. CHIP 180 5% 20X40
R335	NOTPLACED	NOTPLACED
R380	0662057N47	RES. CHIP 1.0 MEG 5% 20X40
R401	0662057M90	RES. CHIP 4700 5% 20X40
R402	0662057M01	RES. CHIP 0 5% 20X40

Ref. Des.	Part Number	Description
R403	0662057M01	RES. CHIP 0 5% 20X40
R404	0662057M01	RES. CHIP 0 5% 20X40
R405	0662057M01	RES. CHIP 0 5% 20X40
R406	0662057M01	RES. CHIP 0 5% 20X40
R413	0662057M01	RES. CHIP 0 5% 20X40
R414	0662057M98	RES. CHIP 10K 5% 20X40
R415	0662057M01	RES. CHIP 0 5% 20X40
R416	0662057M01	RES. CHIP 0 5% 20X40
R417	0662057M01	RES. CHIP 0 5% 20X40
R418	0662057M01	RES. CHIP 0 5% 20X40
R419	0662057M98	RES. CHIP 10K 5% 20X40
R427	NOTPLACED	NOTPLACED
R440	NOTPLACED	NOTPLACED
R441	NOTPLACED	NOTPLACED
R442	0662057M01	RES. CHIP 0 5% 20X40
R444	0662057M01	RES. CHIP 0 5% 20X40
R450	0662057N15	RES. CHIP 47K 5% 20X40
R451	0662057M78	RES. CHIP 1500 5% 20X40
R452	0662057M42	RES. CHIP 47 5% 20X40
R453	0662057N11	RES. CHIP 33K 5% 20X40
R454	0662057M64	RES. CHIP 390 5% 20X40
R455	0662057M74	RES. CHIP 1000 5% 20X40
R456	NOTPLACED	NOTPLACED
R457	0662057M90	RES. CHIP 4700 5% 20X40
R461	NOTPLACED	NOTPLACED
R501	0662057M01	RES. CHIP 0 5% 20X40
R502	0662057M01	RES. CHIP 0 5% 20X40
R503	0662057M01	RES. CHIP 0 5% 20X40
R504	0662057N06	RES. CHIP 20K 5% 20X40
R505	0662057M98	RES. CHIP 10K 5% 20X40
R507	NOTPLACED	NOTPLACED
R508	NOTPLACED	NOTPLACED
R509	NOTPLACED	NOTPLACED
R510	0662057M98	RES. CHIP 10K 5% 20X40
R511	NOTPLACED	NOTPLACED
R512	NOTPLACED	NOTPLACED
R514	0662057N06	RES. CHIP 20K 5% 20X40
R515	0662057N06	RES. CHIP 20K 5% 20X40
R516	0662057M67	RES. CHIP 510 5% 20X40

Ref. Des.	Part Number	Description
R519	0662057M98	RES. CHIP 10K 5% 20X40
R520	0662057U84	RES CHIP 2K 1% 1/16W
R522	0662057N15	RES. CHIP 47K 5% 20X40
R523	0662057N15	RES. CHIP 47K 5% 20X40
R524	0662057N17	RES. CHIP 56K 5% 20X40
R525	0662057N06	RES. CHIP 20K 5% 20X40
R526	0662057V02	RES CHIP 10K 1% 1/16W
R527	0662057M74	RES. CHIP 1000 5% 20X40
R528	0662057M74	RES. CHIP 1000 5% 20X40
R531	0662057M64	RES. CHIP 390 5% 20X40
R533	0662057M82	RES. CHIP 2200 5% 20X40
R536	0662057N23	RES. CHIP 100K 5% 20X40
R537	0662057N10	RES. CHIP 30K 5% 20X40
R538	0662057M01	RES. CHIP 0 5% 20X40
R539	0662057M01	RES. CHIP 0 5% 20X40
R540	0662057M95	RES. CHIP 7500 5% 20X40
R545	0662057M98	RES. CHIP 10K 5% 20X40
R548	0662057N06	RES. CHIP 20K 5% 20X40
R549	0662057M96	RES. CHIP 8200 5% 20X40
R550	0662057V25	RES CHIP 82K 1% 1/16
R551	0662057N06	RES. CHIP 20K 5% 20X40
R553	0662057M96	RES. CHIP 8200 5% 20X40
R554	0662057V25	RES CHIP 82K 1% 1/16
R555	0662057M74	RES. CHIP 1000 5% 20X40
R556	0662057N06	RES. CHIP 20K 5% 20X40
R557	0662057M98	RES. CHIP 10K 5% 20X40
R558	0662057M94	RES. CHIP 6800 5% 20X40
R559	0662057M98	RES. CHIP 10K 5% 20X40
R560	0662057M01	RES. CHIP 0 5% 20X40
R561	0662057M74	RES. CHIP 1000 5% 20X40
R563	0662057M67	RES. CHIP 510 5% 20X40
R564	0662057M98	RES. CHIP 10K 5% 20X40
R565	0662057M82	RES. CHIP 2200 5% 20X40
R566	0662057M95	RES. CHIP 7500 5% 20X40
R567	0662057N15	RES. CHIP 47K 5% 20X40
R568	0662057N15	RES. CHIP 47K 5% 20X40
R569	0662057M90	RES. CHIP 4700 5% 20X40
R572	0662057M50	RES. CHIP 100 5% 20X40
R573	0662057N23	RES. CHIP 100K 5% 20X40

Ref. Des.	Part Number	Description
R574	0662057N23	RES. CHIP 100K 5% 20X40
R575	0662057M98	RES. CHIP 10K 5% 20X40
R576	0662057N23	RES. CHIP 100K 5% 20X40
R577	0662057N15	RES. CHIP 47K 5% 20X40
R578	0662057N15	RES. CHIP 47K 5% 20X40
R581	0662057M01	RES. CHIP 0 5% 20X40
R582	0662057M90	RES. CHIP 4700 5% 20X40
R583	0662057M90	RES. CHIP 4700 5% 20X40
R584	0662057M98	RES. CHIP 10K 5% 20X40
R585	0662057M98	RES. CHIP 10K 5% 20X40
R586	0662057N39	RES. CHIP 470K 5% 20X40
R587	0662057M34	RES. CHIP 22 5% 20X40
R588	0662057M34	RES. CHIP 22 5% 20X40
R589	0662057M98	RES. CHIP 10K 5% 20X40
R590	NOTPLACED	NOTPLACED
R591	NOTPLACED	NOTPLACED
R592	0662057M50	RES. CHIP 100 5% 20X40
R593	0662057M50	RES. CHIP 100 5% 20X40
R594	0662057M64	RES. CHIP 390 5% 20X40
R595	0662057B47	CHIP RES 0 OHMS +/- .050 OHMS
R596	NOTPLACED	NOTPLACED
R597	0662057M01	RES. CHIP 0 5% 20X40
R598	NOTPLACED	NOTPLACED
R599	NOTPLACED	NOTPLACED
SH101	2685462E01	SHEILD PATRIOT
SH102	2685665E01	SHEILD FLIPPER
U201	5109731C15	IC OP AMP SNGL OPA237 SOT23
U202	5109731C15	IC OP AMP SNGL OPA237 SOT23
U301	5185368C66	IC CUSTOM FLIPPER
U302	5105492X92	IC CMOS BILATERAL SWITCH
U303	5109522E53	IC SNGL BUF NC7S125P5X SC70
U304	5109522E53	IC SNGL BUF NC7S125P5X SC70
U305	5109522E53	IC SNGL BUF NC7S125P5X SC70

Ref. Des.	Part Number	Description
U306	5109522E53	IC SNGL BUF NC7S125P5X SC70
U307	5109522E53	IC SNGL BUF NC7S125P5X SC70
U308	5109817F62	IC SPDT SWITCH/ MULTIPLEXER
U309	5109817F62	IC SPDT SWITCH/ MULTIPLEXER
U310	5187970L15	IC USB TRANS FULL- SPEED
U311	5105492X03	IC SNG HI SPD L-MOS NOT GATE
U312	5185368C12	IC 1.8V SN LOGIC GATE
U314	5109522E53	IC SNGL BUF NC7S125P5X SC70
U401	5109841C69	IC 256 BGA 17X17 PACKAGE PATRIOT
U402	5185956E15	IC FLASH 64MB 1.8V 60NS
U403	5185368C82	IC 1.65 TO 2.2V, 70NS, 8MBIT SRAM
U404	5109522E53	IC SNGL BUF NC7S125P5X SC70
U405	5109522E53	IC SNGL BUF NC7S125P5X SC70
U406	5105492X03	IC SNG HI SPD L-MOS NOT GATE
U407	5105109Z31	IC QUAD 2:1 MUX/DEMUX
U408	5109522E53	IC SNGL BUF NC7S125P5X SC70
U501	5109879E58	IC 4.3 GCAPII SN104616DGGMR BG
U502	5109731C15	IC OP AMP SNGL OPA237 SOT23
U503	5102463J44	IC AUDIO PA (PHILIPS_20PIN)
U504	5109731C15	IC OP AMP SNGL OPA237 SOT23
U505	5185353D13	IC MINI SO-8 HI PRECISION REG 5V
U507	5109731C15	IC OP AMP SNGL OPA237 SOT23
U508	NOTPLACED	NOTPLACED
U509	5185353D35	IC DUAL EEPOT 256 TAP
U510	5105492X92	IC CMOS BILATERAL SWITCH

Ref. Des.	Part Number	Description
U511	5185353D56	IC 3.3V LINEAR REGULATOR MC78LC 33NTR
U512	NOTPLACED	NOTPLACED
VR201	4813832C72	TRANS SUP QUAD 12V
VR202	4813830A22	DIODE 9.1V 5% 225MW MMBZ5239B_
VR203	4813832C72	TRANS SUP QUAD 12V
VR204	4813830C26	DIODE 13V 'H3' MMSZ5243BT1
VR205	4805656W08	DIODE ZENER QUAD
VR206	4805656W08	DIODE ZENER QUAD
VR209	4813832C72	TRANS SUP QUAD 12V
VR220	4805656W03	DIODE DUAL 5.6V ZENER
VR221	4805656W03	DIODE DUAL 5.6V ZENER
VR501	4813830A15	DIODE 5.6V 5% 225MW MMBZ5232B_
Y301	4809995L05	XTAL QUARTZ 32.768KHZ CC4V-T1





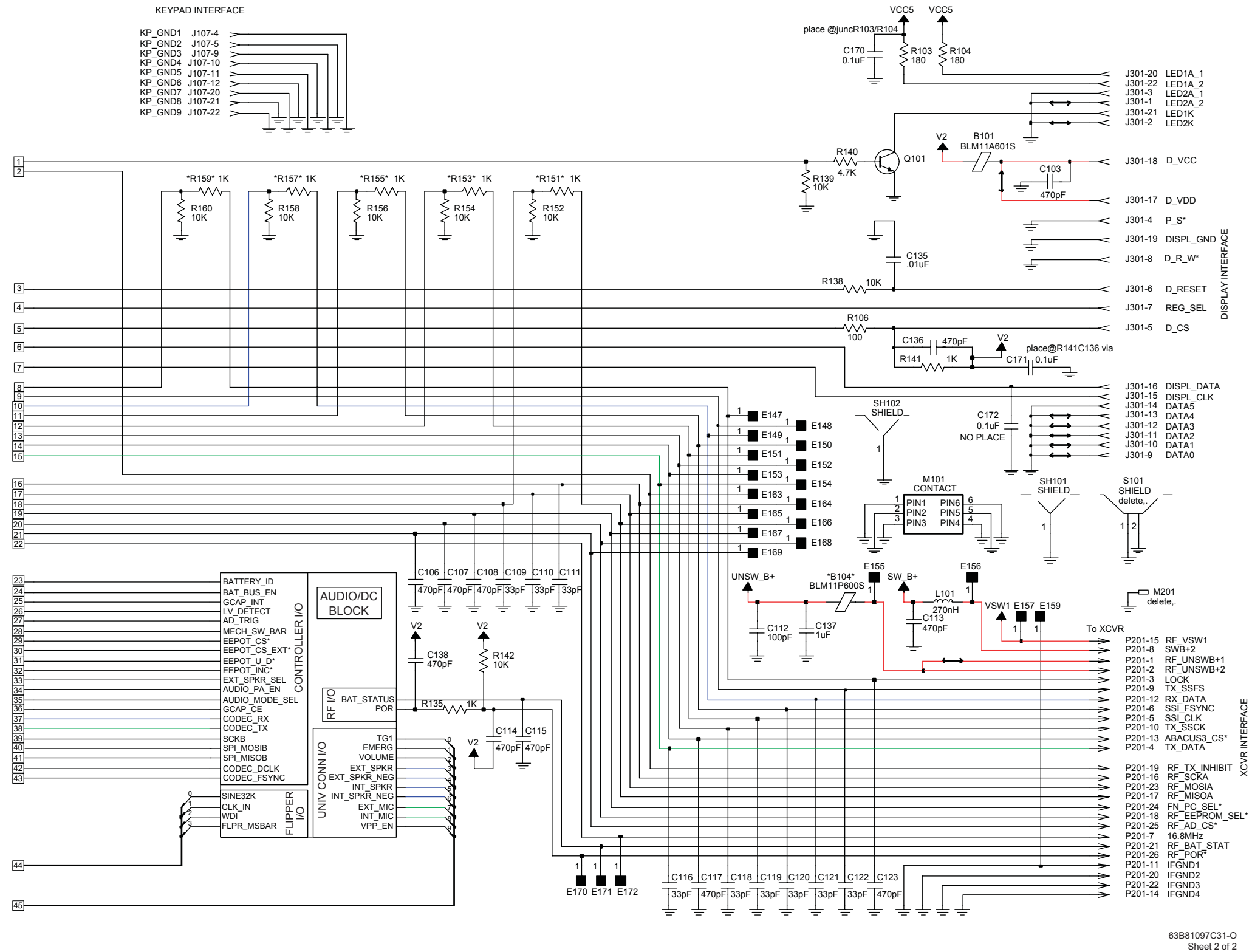

63B81097C31-O  
Sheet 2 of 2

Figure 8-98. NNTN4717D VOCON Board Overall Schematic—Sheet 2 of 2



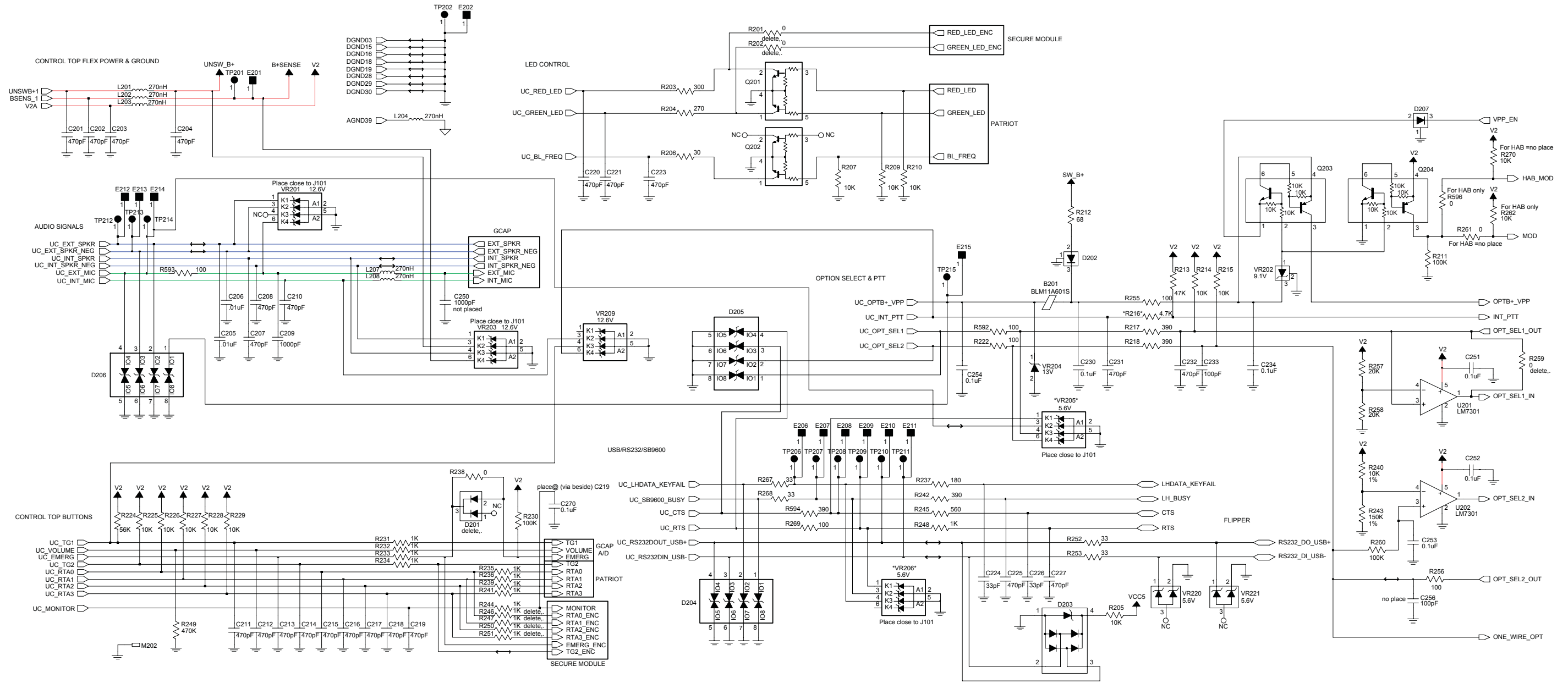

63B81097C30-O

Figure 8-99. NNTN4717D VOCON Board Universal Connector Circuit Schematic

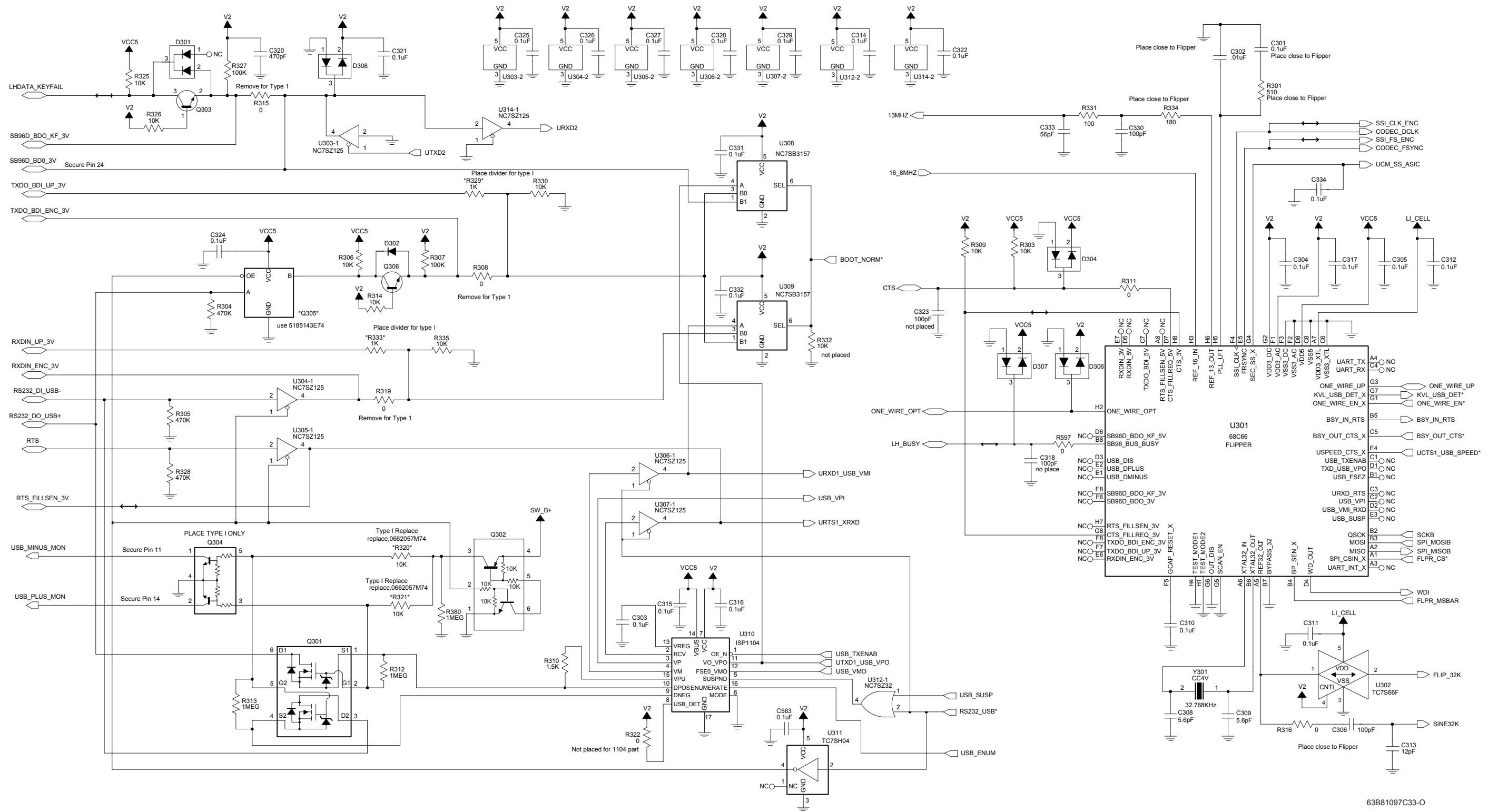

Figure 8-100. NNTN4717D VOCON Board Flipper Circuit

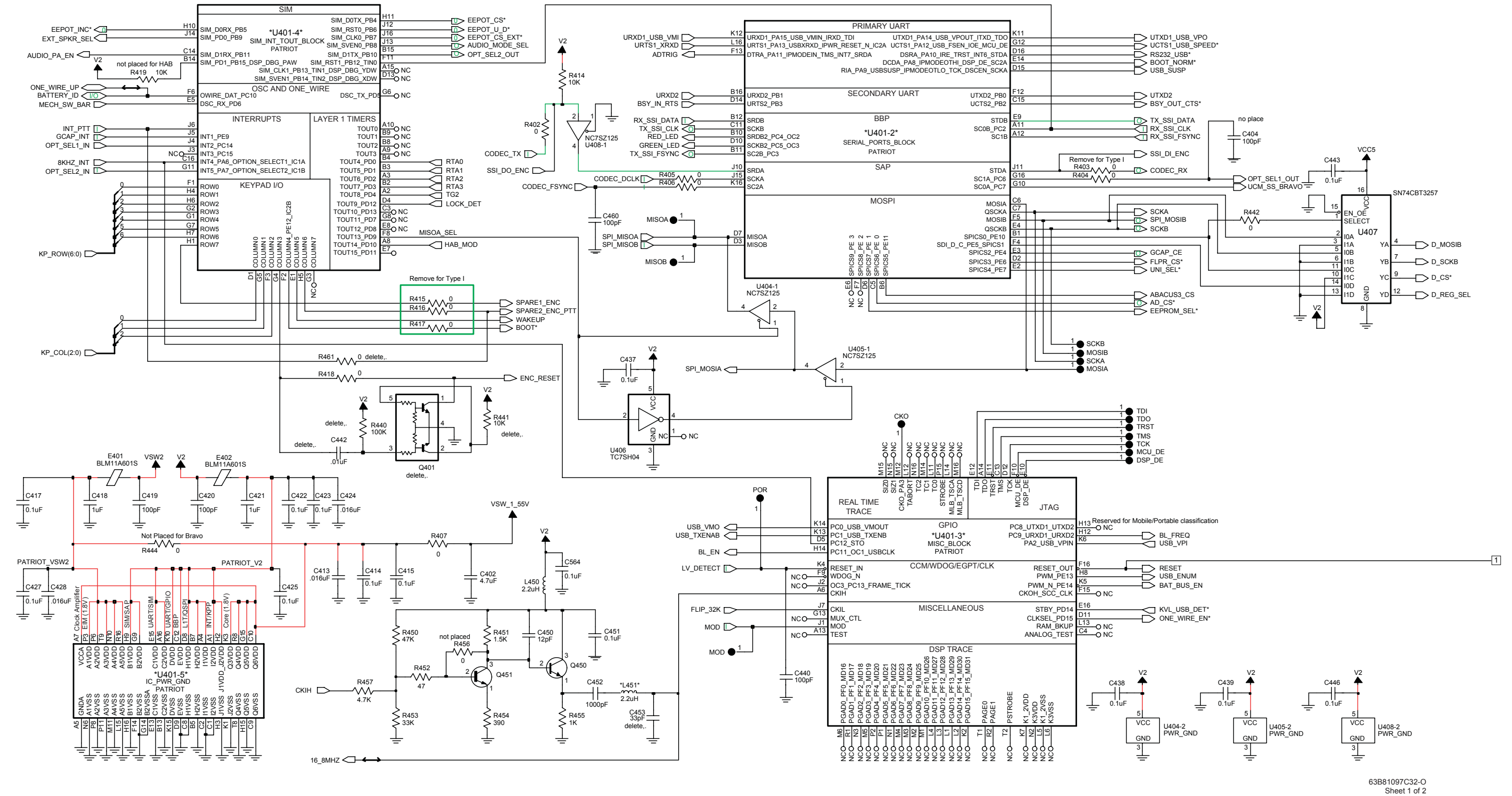
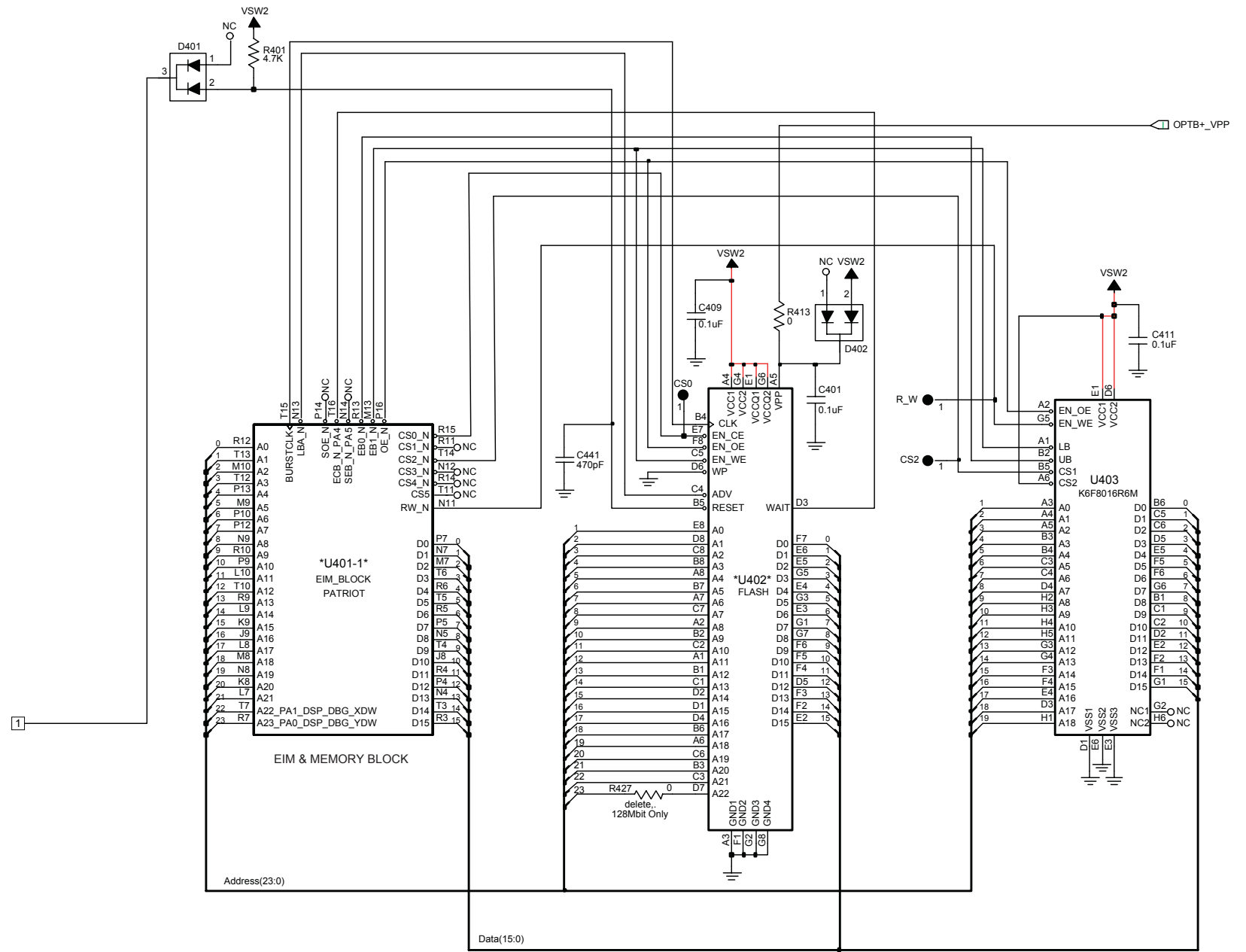
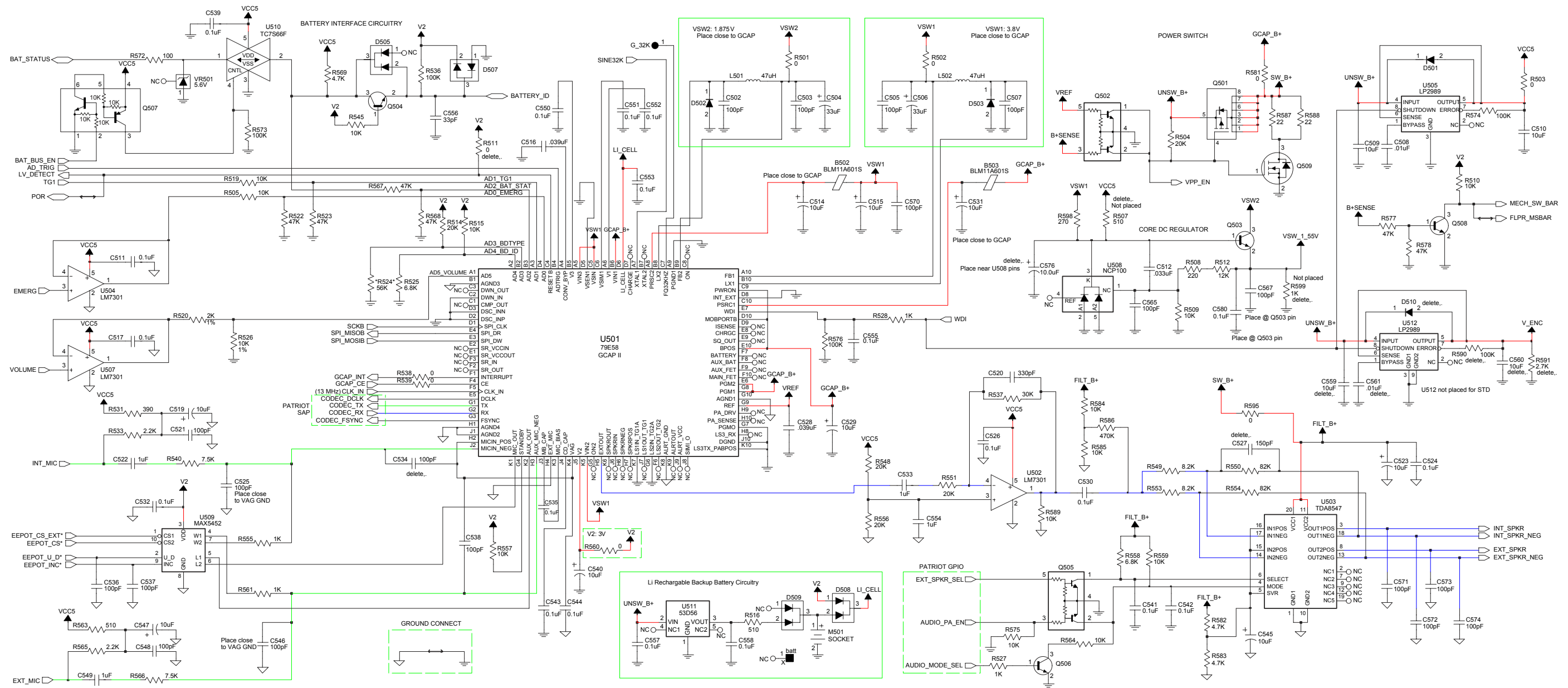

Figure 8-101. NNTN4717D VOCON Board Controller and Memory Circuits—Sheet 1 of 2



63B81097C32-0  
Sheet 2 of 2

Figure 8-102. NNTN4717D VOCON Board Controller and Memory Circuits—Sheet 2 of 2



63B81097C34-O

Figure 8-103. NNTN4717D VOCON Board Audio/DC Circuits





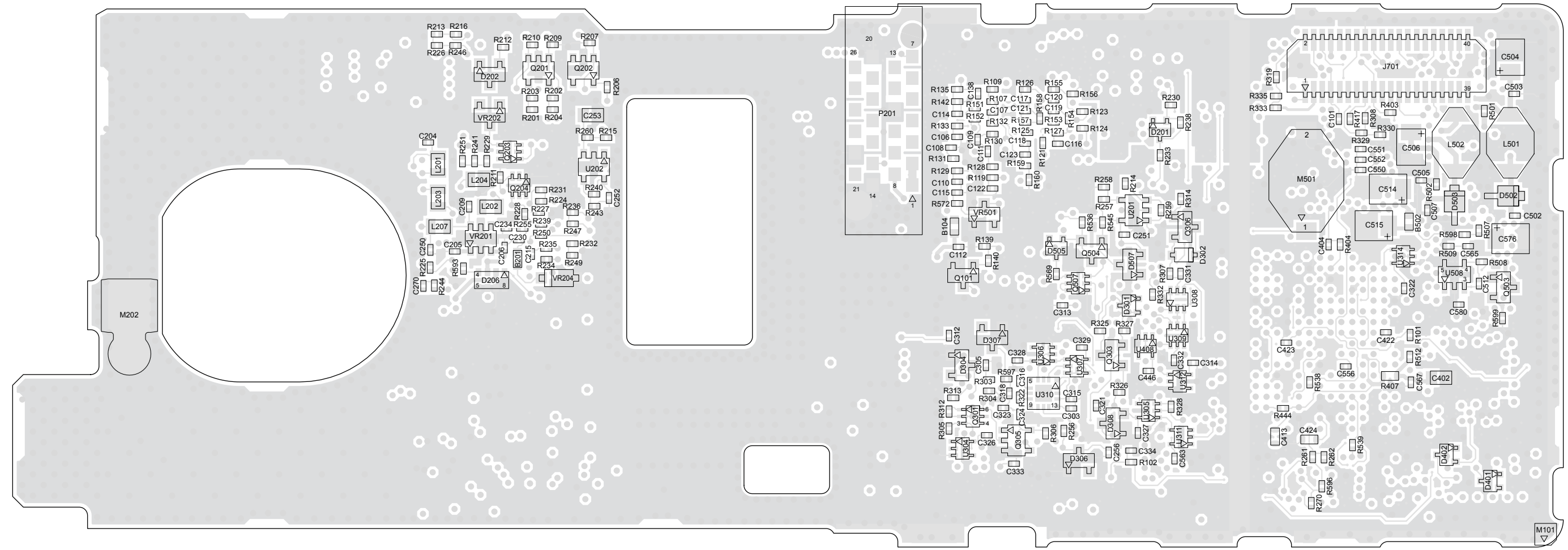

MAEPF-27673-O

Figure 8-105. NNTN4717D VOCON Board Layout—Side 2

## NNTN4717D VOCON Board Parts List

Ref. Des.	Part Number	Description
B104	2462586G33	INDUCTOR CHIP FERRITE BEADS
B101	2480574F01	IND FERRITE CHIP 600 OHM 0603
B201	2480574F01	IND FERRITE CHIP 600 OHM 0603
B502	2480574F01	IND FERRITE CHIP 600 OHM 0603
B503	2480574F01	IND FERRITE CHIP 600 OHM 0603
BATT	6003710K08	BAT,LI,3.3V,3MAH,,COINCELL,RECHARGA
C101	2113743L09	CAP CHIP 470 PF 10% X7R
C102	2113743L09	CAP CHIP 470 PF 10% X7R
C103	2113743L09	CAP CHIP 470 PF 10% X7R
C104	2113743L09	CAP CHIP 470 PF 10% X7R
C106	2113743L09	CAP CHIP 470 PF 10% X7R
C107	2113743L09	CAP CHIP 470 PF 10% X7R
C108	2113743L09	CAP CHIP 470 PF 10% X7R
C109	2113743N38	CAP CHIP 33.0 PF 5% COG
C110	2113743N38	CAP CHIP 33.0 PF 5% COG
C111	2113743N38	CAP CHIP 33.0 PF 5% COG
C112	2113743N50	CAP CHIP 100 PF 5% COG
C113	2113743L09	CAP CHIP 470 PF 10% X7R
C114	2113743L09	CAP CHIP 470 PF 10% X7R
C115	2113743L09	CAP CHIP 470 PF 10% X7R
C116	2113743N38	CAP CHIP 33.0 PF 5% COG
C117	2113743L09	CAP CHIP 470 PF 10% X7R
C118	2113743N38	CAP CHIP 33.0 PF 5% COG
C119	2113743N38	CAP CHIP 33.0 PF 5% COG
C120	2113743N38	CAP CHIP 33.0 PF 5% COG
C121	2113743N38	CAP CHIP 33.0 PF 5% COG
C122	2113743N38	CAP CHIP 33.0 PF 5% COG
C123	2113743L09	CAP CHIP 470 PF 10% X7R
C124	2113743L09	CAP CHIP 470 PF 10% X7R
C125	2113743L09	CAP CHIP 470 PF 10% X7R
C126	2113743L09	CAP CHIP 470 PF 10% X7R
C127	2113743L09	CAP CHIP 470 PF 10% X7R
C128	2113743L09	CAP CHIP 470 PF 10% X7R

Ref. Des.	Part Number	Description
C129	2113743L09	CAP CHIP 470 PF 10% X7R
C130	2113743L09	CAP CHIP 470 PF 10% X7R
C131	2113743L09	CAP CHIP 470 PF 10% X7R
C132	2113743L09	CAP CHIP 470 PF 10% X7R
C133	2113743L09	CAP CHIP 470 PF 10% X7R
C134	2113743L09	CAP CHIP 470 PF 10% X7R
C135	2113743L41	CAP CHIP 10000 PF 10% X7R
C136	2113743L09	CAP CHIP 470 PF 10% X7R
C137	2113743A31	CAP CHIP 1.0 UF 10% X7R
C138	2113743L09	CAP CHIP 470 PF 10% X7R
C170	2113743M24	CAP CHIP 100000 PF +80-20% Y5V
C171	2113743M24	CAP CHIP 100000 PF +80-20% Y5V
C172	NOTPLACED	64AM DUMMY PART NUMBER
C201	2113743L09	CAP CHIP 470 PF 10% X7R
C202	2113743L09	CAP CHIP 470 PF 10% X7R
C203	2113743L09	CAP CHIP 470 PF 10% X7R
C204	2113743L09	CAP CHIP 470 PF 10% X7R
C205	2113743L41	CAP CHIP 10000 PF 10% X7R
C206	2113743L41	CAP CHIP 10000 PF 10% X7R
C207	2113743L09	CAP CHIP 470 PF 10% X7R
C208	2113743L09	CAP CHIP 470 PF 10% X7R
C209	2113743L17	CAP CHIP 1000 PF 10% X7R
C210	2113743L09	CAP CHIP 470 PF 10% X7R
C211	2113743L09	CAP CHIP 470 PF 10% X7R
C212	2113743L09	CAP CHIP 470 PF 10% X7R
C213	2113743L09	CAP CHIP 470 PF 10% X7R
C214	2113743L09	CAP CHIP 470 PF 10% X7R
C215	2113743L09	CAP CHIP 470 PF 10% X7R
C216	2113743L09	CAP CHIP 470 PF 10% X7R
C217	2113743L09	CAP CHIP 470 PF 10% X7R
C218	2113743L09	CAP CHIP 470 PF 10% X7R
C219	2113743L09	CAP CHIP 470 PF 10% X7R
C220	2113743L09	CAP CHIP 470 PF 10% X7R
C221	2113743L09	CAP CHIP 470 PF 10% X7R

Ref. Des.	Part Number	Description
C223	2113743L09	CAP CHIP 470 PF 10% X7R
C224	2113743N38	CAP CHIP 33.0 PF 5% COG
C225	2113743L09	CAP CHIP 470 PF 10% X7R
C226	2113743N38	CAP CHIP 33.0 PF 5% COG
C227	2113743L09	CAP CHIP 470 PF 10% X7R
C230	2113743M24	CAP CHIP 100000 PF +80-20% Y5V
C231	2113743L09	CAP CHIP 470 PF 10% X7R
C232	2113743L09	CAP CHIP 470 PF 10% X7R
C233	2113743N50	CAP CHIP 100 PF 5% COG
C234	2113743M24	CAP CHIP 100000 PF +80-20% Y5V
C250	NOTPLACED	64AM DUMMY PART NUMBER
C251	2113743M24	CAP CHIP 100000 PF +80-20% Y5V
C252	2113743M24	CAP CHIP 100000 PF +80-20% Y5V
C253	2113743A19	CAP CHIP .100 UF 10% X7R
C254	2113743M24	CAP CHIP 100000 PF +80-20% Y5V
C256	NOTPLACED	64AM DUMMY PART NUMBER
C270	2113743M24	CAP CHIP 100000 PF +80-20% Y5V
C301	2113743E20	CAP CHIP .10 UF 10%
C302	2113743L41	CAP CHIP 10000 PF 10% X7R
C303	2113743M24	CAP CHIP 100000 PF +80-20% Y5V
C304	2113743M24	CAP CHIP 100000 PF +80-20% Y5V
C305	2113743M24	CAP CHIP 100000 PF +80-20% Y5V
C306	2113743N50	CAP CHIP 100 PF 5% COG
C308	2113743N20	CAP CHIP 5.6 PF + .5PF COG
C309	2113743N20	CAP CHIP 5.6 PF + .5PF COG
C310	2113743M24	CAP CHIP 100000 PF +80-20% Y5V
C311	2113743M24	CAP CHIP 100000 PF +80-20% Y5V

Ref. Des.	Part Number	Description
C312	2113743M24	CAP CHIP 100000 PF +80-20% Y5V
C313	2113743N28	CAP CHIP 12.0 PF 5% COG
C314	2113743M24	CAP CHIP 100000 PF +80-20% Y5V
C315	2113743M24	CAP CHIP 100000 PF +80-20% Y5V
C316	2113743M24	CAP CHIP 100000 PF +80-20% Y5V
C317	2113743M24	CAP CHIP 100000 PF +80-20% Y5V
C318	NOTPLACED	64AM DUMMY PART NUMBER
C320	2113743L09	CAP CHIP 470 PF 10% X7R
C321	2113743M24	CAP CHIP 100000 PF +80-20% Y5V
C322	2113743M24	CAP CHIP 100000 PF +80-20% Y5V
C323	NOTPLACED	64AM DUMMY PART NUMBER
C324	2113743M24	CAP CHIP 100000 PF +80-20% Y5V
C325	2113743M24	CAP CHIP 100000 PF +80-20% Y5V
C326	2113743M24	CAP CHIP 100000 PF +80-20% Y5V
C327	2113743M24	CAP CHIP 100000 PF +80-20% Y5V
C328	2113743M24	CAP CHIP 100000 PF +80-20% Y5V
C329	2113743M24	CAP CHIP 100000 PF +80-20% Y5V
C330	2113743N50	CAP CHIP 100 PF 5% COG
C331	2113743M24	CAP CHIP 100000 PF +80-20% Y5V
C332	2113743M24	CAP CHIP 100000 PF +80-20% Y5V
C333	2113743N44	CAP CHIP 56.0 PF 5% COG
C334	2113743M24	CAP CHIP 100000 PF +80-20% Y5V
C401	2113743M24	CAP CHIP 100000 PF +80-20% Y5V
C402	2113928C04	CAP CER CHIP 4.7UF 6.3V10%0805



Ref. Des.	Part Number	Description
C404	NOTPLACED	64AM DUMMY PART NUMBER
C409	2113743M24	CAP CHIP 100000 PF +80-20% Y5V
C411	2113743M24	CAP CHIP 100000 PF +80-20% Y5V
C413	2113743E04	CER CHIP CAP .016UF
C414	2113743M24	CAP CHIP 100000 PF +80-20% Y5V
C415	2113743M24	CAP CHIP 100000 PF +80-20% Y5V
C417	2113743M24	CAP CHIP 100000 PF +80-20% Y5V
C418	2113743A31	CAP CHIP 1.0 UF 10% X7R
C419	2113743N50	CAP CHIP 100 PF 5% COG
C420	2113743N50	CAP CHIP 100 PF 5% COG
C421	2113743A31	CAP CHIP 1.0 UF 10% X7R
C422	2113743M24	CAP CHIP 100000 PF +80-20% Y5V
C423	2113743M24	CAP CHIP 100000 PF +80-20% Y5V
C424	2113743E04	CER CHIP CAP .016UF
C425	2113743M24	CAP CHIP 100000 PF +80-20% Y5V
C427	2113743M24	CAP CHIP 100000 PF +80-20% Y5V
C428	2113743E04	CER CHIP CAP .016UF
C437	2113743M24	CAP CHIP 100000 PF +80-20% Y5V
C438	2113743M24	CAP CHIP 100000 PF +80-20% Y5V
C439	2113743M24	CAP CHIP 100000 PF +80-20% Y5V
C440	2113743N50	CAP CHIP 100 PF 5% COG
C441	2113743L09	CAP CHIP 470 PF 10% X7R
C442	NOTPLACED	64AM DUMMY PART NUMBER
C443	2113743M24	CAP CHIP 100000 PF +80-20% Y5V
C446	2113743M24	CAP CHIP 100000 PF +80-20% Y5V
C450	2113743N28	CAP CHIP 12.0 PF 5% COG
C451	2113743E20	CAP CHIP .10 UF 10%

Ref. Des.	Part Number	Description
C452	2113743L17	CAP CHIP 1000 PF 10% X7R
C453	NOTPLACED	64AM DUMMY PART NUMBER
C460	NOTPLACED	64AM DUMMY PART NUMBER
C502	2113743N50	CAP CHIP 100 PF 5% COG
C503	2113743N50	CAP CHIP 100 PF 5% COG
C504	2311049C52	CAP TANT CHIP 33UF 10% 10V
C505	2113743N50	CAP CHIP 100 PF 5% COG
C506	2311049C52	CAP TANT CHIP 33UF 10% 10V
C507	2113743N50	CAP CHIP 100 PF 5% COG
C508	2113743L41	CAP CHIP 10000 PF 10% X7R
C509	2113743T19	CAP 10UF 16V CER 3225 X5R
C510	2113743T19	CAP 10UF 16V CER 3225 X5R
C511	2113743M24	CAP CHIP 100000 PF +80-20% Y5V
C512	2113743L50	CAP CHIP 33000 PF 10%
C514	2311049A57	CAP TANT CHIP A/P 10UF 10% 16V
C515	2311049A57	CAP TANT CHIP A/P 10UF 10% 16V
C516	2113743E11	CAP CHIP .039 UF 10% X7R
C517	2113743M24	CAP CHIP 100000 PF +80-20% Y5V
C519	2311049A57	CAP TANT CHIP A/P 10UF 10% 16V
C520	2113743L05	CAP CHIP 330 PF 10% X7R
C521	2113743N50	CAP CHIP 100 PF 5% COG
C522	2113743A31	CAP CHIP 1.0 UF 10% X7R
C523	2311049A57	CAP TANT CHIP A/P 10UF 10% 16V
C524	2113743M24	CAP CHIP 100000 PF +80-20% Y5V
C525	2113743N50	CAP CHIP 100 PF 5% COG
C526	2113743M24	CAP CHIP 100000 PF +80-20% Y5V

Ref. Des.	Part Number	Description
C527	NOTPLACED	64AM DUMMY PART NUMBER
C528	2113743E11	CAP CHIP .039 UF 10% X7R
C529	2311049A57	CAP TANT CHIP A/P 10UF 10% 16V
C530	2113743A19	CAP CHIP .100 UF 10% X7R
C531	2311049A57	CAP TANT CHIP A/P 10UF 10% 16V
C532	2113743M24	CAP CHIP 100000 PF +80-20% Y5V
C533	2113743A31	CAP CHIP 1.0 UF 10% X7R
C534	NOTPLACED	64AM DUMMY PART NUMBER
C535	2113743M24	CAP CHIP 100000 PF +80-20% Y5V
C536	2113743N50	CAP CHIP 100 PF 5% COG
C537	2113743N50	CAP CHIP 100 PF 5% COG
C538	2113743N50	CAP CHIP 100 PF 5% COG
C539	2113743M24	CAP CHIP 100000 PF +80-20% Y5V
C540	2311049A57	CAP TANT CHIP A/P 10UF 10% 16V
C541	2113743M24	CAP CHIP 100000 PF +80-20% Y5V
C542	2113743M24	CAP CHIP 100000 PF +80-20% Y5V
C543	2113743M24	CAP CHIP 100000 PF +80-20% Y5V
C544	2113743M24	CAP CHIP 100000 PF +80-20% Y5V
C545	2311049A57	CAP TANT CHIP A/P 10UF 10% 16V
C546	2113743N50	CAP CHIP 100 PF 5% COG
C547	2311049A57	CAP TANT CHIP A/P 10UF 10% 16V
C548	2113743N50	CAP CHIP 100 PF 5% COG
C549	2113743A31	CAP CHIP 1.0 UF 10% X7R
C550	2113743M24	CAP CHIP 100000 PF +80-20% Y5V
C551	2113743M24	CAP CHIP 100000 PF +80-20% Y5V
C552	2113743M24	CAP CHIP 100000 PF +80-20% Y5V

Ref. Des.	Part Number	Description
C553	2113743M24	CAP CHIP 100000 PF +80-20% Y5V
C554	2113743A31	CAP CHIP 1.0 UF 10% X7R
C555	2113743M24	CAP CHIP 100000 PF +80-20% Y5V
C556	2113743N38	CAP CHIP 33.0 PF 5% COG
C557	2113743M24	CAP CHIP 100000 PF +80-20% Y5V
C558	2113743M24	CAP CHIP 100000 PF +80-20% Y5V
C559	NOTPLACED	64AM DUMMY PART NUMBER
C560	NOTPLACED	64AM DUMMY PART NUMBER
C561	NOTPLACED	64AM DUMMY PART NUMBER
C563	2113743M24	CAP CHIP 100000 PF +80-20% Y5V
C564	2113743M24	CAP CHIP 100000 PF +80-20% Y5V
C565	2113743N50	CAP CHIP 100 PF 5% COG
C567	2113743N50	CAP CHIP 100 PF 5% COG
C570	2113743N50	CAP CHIP 100 PF 5% COG
C571	2113743N50	CAP CHIP 100 PF 5% COG
C572	2113743N50	CAP CHIP 100 PF 5% COG
C573	2113743N50	CAP CHIP 100 PF 5% COG
C574	2113743N50	CAP CHIP 100 PF 5% COG
C576	NOTPLACED	64AM DUMMY PART NUMBER
C580	2113743M24	CAP CHIP 100000 PF +80-20% Y5V
D201	NOTPLACED	64AM DUMMY PART NUMBER
D202	4805129M90	DIODE SOT PKGD
D203	4802021P15	ZENER SR05
D204	4805656W39	QUAD ESD SUPPRESSOR ARRAY -41206ESD
D205	4805656W39	QUAD ESD SUPPRESSOR ARRAY -41206ESD
D206	4805656W39	QUAD ESD SUPPRESSOR ARRAY -41206ESD
D207	4805129M90	DIODE SOT PKGD
D301	4805218N57	DIODE DUAL

Ref. Des.	Part Number	Description
D302	4805656W37	TSTR BAT54HT1
D304	4805129M06	DIODE MMBD7000
D306	4805129M06	DIODE MMBD7000
D307	4805129M06	DIODE MMBD7000
D308	4805129M06	DIODE MMBD7000
D401	4805218N57	DIODE DUAL
D402	4805218N57	DIODE DUAL
D501	4813833A20	DIODE SCHOTTKY 1A 40V PWRMITE
D502	4813833A20	DIODE SCHOTTKY 1A 40V PWRMITE
D503	4813833A20	DIODE SCHOTTKY 1A 40V PWRMITE
D505	4805218N57	DIODE DUAL
D507	4805129M06	DIODE MMBD7000
D508	4805218N57	DIODE DUAL
D509	4805218N57	DIODE DUAL
D510	NOTPLACED	64AM DUMMY PART NUMBER
E401	2480574F01	IND FERRITE CHIP 600 OHM 0603
E402	2480574F01	IND FERRITE CHIP 600 OHM 0603
J101	0985185D01	CONN RECP 0.5MM PITCH 40 CKTS
J107	0987817K01	CONN,RCPT,M,22CONT,,G OLD/NICKEL,SM,
J301	0987817K01	CONN,RCPT,M,22CONT,,G OLD/NICKEL,SM,
J701	0980423L02	CONN 40 POS PAK-8
L101	2404574Z14	IND CHIP WW 270NH 2% 2012 SMD
L201	2404574Z14	IND CHIP WW 270NH 2% 2012 SMD
L202	2404574Z14	IND CHIP WW 270NH 2% 2012 SMD
L203	2404574Z14	IND CHIP WW 270NH 2% 2012 SMD
L204	2404574Z14	IND CHIP WW 270NH 2% 2012 SMD
L207	2404574Z14	IND CHIP WW 270NH 2% 2012 SMD
L208	2404574Z14	IND CHIP WW 270NH 2% 2012 SMD

Ref. Des.	Part Number	Description
L450	2462587Q20	"IND CHIP 2,200 NH 20%"
L451	0662057C01	CHIP RES 0 OHMS +.050 OHMS
L501	2486085A06	COIL 47UH SMT POWER INDUCTOR
L502	2486085A06	COIL 47UH SMT POWER INDUCTOR
M202	3985951A01	CONTACT ANTENNA GROUND
M501	0985888K02	SKT RTC BTTY LEAP
PCB	8485871E04	PCB XTS5000
Q101	4813824A10	TSTR NPN 40V .2A GEN PURP
Q201	4805921T09	XSTR DUAL ROHM FMG8
Q202	4805921T09	XSTR DUAL ROHM FMG8
Q203	4805723X03	TRANS DUAL NPN-PNP UMD3N ROHM
Q204	4805723X03	TRANS DUAL NPN-PNP UMD3N ROHM
Q301	4809579E35	TSTR FET DUAL N-CHAN FDG3601N
Q302	4805723X03	TRANS DUAL NPN-PNP UMD3N ROHM
Q303	4813824A10	TSTR NPN 40V .2A GEN PURP
Q304	NOTPLACED	64AM DUMMY PART NUMBER
Q305	5185143E74	IC SINGLE FET BUS SWITCH
Q306	4813824A10	TSTR NPN 40V .2A GEN PURP
Q401	NOTPLACED	64AM DUMMY PART NUMBER
Q450	4805793Y01	TRANS MINI SOT NPN LOW NOISE
Q451	4805793Y01	TRANS MINI SOT NPN LOW NOISE
Q501	4885844C01	XSTR FET
Q502	4805921T09	XSTR DUAL ROHM FMG8
Q503	4813824A13	XSTR NPN 80V .5A DRIVER B=50
Q504	4813824A10	TSTR NPN 40V .2A GEN PURP
Q505	4805921T09	XSTR DUAL ROHM FMG8

Ref. Des.	Part Number	Description
Q506	4813824A10	TSTR NPN 40V .2A GEN PURP
Q507	4805723X03	TRANS DUAL NPN-PNP UMD3N ROHM
Q508	4813824A10	TSTR NPN 40V .2A GEN PURP
Q509	4805218N11	XISTOR SOT RH BST82
R101	0662057M01	RES. CHIP 0 5% 20X40
R102	NOTPLACED	64AM DUMMY PART NUMBER
R103	0662057M56	RES. CHIP 180 5% 20X40
R104	0662057M56	RES. CHIP 180 5% 20X40
R106	0662057M50	RES. CHIP 100 5% 20X40
R107	0662057M98	RES. CHIP 10K 5% 20X40
R109	0662057M01	RES. CHIP 0 5% 20X40
R119	0662057M50	RES. CHIP 100 5% 20X40
R121	0662057M74	RES. CHIP 1000 5% 20X40
R123	0662057M74	RES. CHIP 1000 5% 20X40
R124	0662057M74	RES. CHIP 1000 5% 20X40
R125	0662057M50	RES. CHIP 100 5% 20X40
R126	0662057M50	RES. CHIP 100 5% 20X40
R127	0662057M74	RES. CHIP 1000 5% 20X40
R128	0662057M74	RES. CHIP 1000 5% 20X40
R129	0662057M74	RES. CHIP 1000 5% 20X40
R130	0662057M74	RES. CHIP 1000 5% 20X40
R131	0662057M50	RES. CHIP 100 5% 20X40
R132	0662057M01	RES. CHIP 0 5% 20X40
R133	0662057M01	RES. CHIP 0 5% 20X40
R135	0662057M74	RES. CHIP 1000 5% 20X40
R138	0662057M98	RES. CHIP 10K 5% 20X40
R139	0662057M98	RES. CHIP 10K 5% 20X40
R140	0662057M90	RES. CHIP 4700 5% 20X40
R141	NOTPLACED	64AM DUMMY PART NUMBER
R142	0662057M98	RES. CHIP 10K 5% 20X40
R143	0662057M01	RES. CHIP 0 5% 20X40
R151	0662057M74	RES. CHIP 1000 5% 20X40
R152	0662057M98	RES. CHIP 10K 5% 20X40
R153	0662057M74	RES. CHIP 1000 5% 20X40
R154	0662057M98	RES. CHIP 10K 5% 20X40

Ref. Des.	Part Number	Description
R155	0662057M74	RES. CHIP 1000 5% 20X40
R156	0662057M98	RES. CHIP 10K 5% 20X40
R157	0662057M74	RES. CHIP 1000 5% 20X40
R158	0662057M98	RES. CHIP 10K 5% 20X40
R159	0662057M74	RES. CHIP 1000 5% 20X40
R160	0662057M98	RES. CHIP 10K 5% 20X40
R201	NOTPLACED	64AM DUMMY PART NUMBER
R202	NOTPLACED	64AM DUMMY PART NUMBER
R203	0662057M61	RES. CHIP 300 5% 20X40
R204	0662057M60	RES. CHIP 270 5% 20X40
R205	0662057M98	RES. CHIP 10K 5% 20X40
R206	0662057M37	20X40 30 OMH 5% CHIP RESISTOR
R207	0662057M98	RES. CHIP 10K 5% 20X40
R209	0662057M98	RES. CHIP 10K 5% 20X40
R210	0662057M98	RES. CHIP 10K 5% 20X40
R211	0662057N23	RES. CHIP 100K 5% 20X40
R212	0662057M46	RES. CHIP 68 5% 20X40
R213	0662057N15	RES. CHIP 47K 5% 20X40
R214	0662057M98	RES. CHIP 10K 5% 20X40
R215	0662057M98	RES. CHIP 10K 5% 20X40
R216	0662057M90	RES. CHIP 4700 5% 20X40
R217	0662057M64	RES. CHIP 390 5% 20X40
R218	0662057M64	RES. CHIP 390 5% 20X40
R222	0662057M50	RES. CHIP 100 5% 20X40
R224	0662057N17	RES. CHIP 56K 5% 20X40
R225	0662057M98	RES. CHIP 10K 5% 20X40
R226	0662057M98	RES. CHIP 10K 5% 20X40
R227	0662057M98	RES. CHIP 10K 5% 20X40
R228	0662057M98	RES. CHIP 10K 5% 20X40
R229	0662057M98	RES. CHIP 10K 5% 20X40
R230	0662057N23	RES. CHIP 100K 5% 20X40
R231	0662057M74	RES. CHIP 1000 5% 20X40
R232	0662057M74	RES. CHIP 1000 5% 20X40
R233	0662057M74	RES. CHIP 1000 5% 20X40
R234	0662057M74	RES. CHIP 1000 5% 20X40
R235	0662057M74	RES. CHIP 1000 5% 20X40
R236	0662057M74	RES. CHIP 1000 5% 20X40

Ref. Des.	Part Number	Description
R237	0662057M56	RES. CHIP 180 5% 20X40
R238	0662057M01	RES. CHIP 0 5% 20X40
R239	0662057M74	RES. CHIP 1000 5% 20X40
R240	0662057V02	RES CHIP 10K 1% 1/16W
R241	0662057M74	RES. CHIP 1000 5% 20X40
R242	0662057M64	RES. CHIP 390 5% 20X40
R243	0662057V32	RESISTOR, 150 KOHM, 20X40, 1%
R244	0662057M74	RES. CHIP 1000 5% 20X40
R245	0662057M68	RES CHIP 560 5% 20X40
R246	NOTPLACED	64AM DUMMY PART NUMBER
R247	NOTPLACED	64AM DUMMY PART NUMBER
R248	0662057M74	RES. CHIP 1000 5% 20X40
R249	0662057N39	RES. CHIP 470K 5% 20X40
R250	NOTPLACED	64AM DUMMY PART NUMBER
R251	NOTPLACED	64AM DUMMY PART NUMBER
R252	0662057M38	RES. CHIP 33 5% 20X40
R253	0662057M38	RES. CHIP 33 5% 20X40
R255	0662057M50	RES. CHIP 100 5% 20X40
R256	0662057M50	RES. CHIP 100 5% 20X40
R257	0662057N06	RES. CHIP 20K 5% 20X40
R258	0662057N06	RES. CHIP 20K 5% 20X40
R259	NOTPLACED	64AM DUMMY PART NUMBER
R260	0662057N23	RES. CHIP 100K 5% 20X40
R261	0662057M01	RES. CHIP 0 5% 20X40
R262	NOTPLACED	64AM DUMMY PART NUMBER
R267	0662057M38	RES. CHIP 33 5% 20X40
R268	0662057M38	RES. CHIP 33 5% 20X40
R269	0662057M50	RES. CHIP 100 5% 20X40
R270	0662057M98	RES. CHIP 10K 5% 20X40
R301	0662057M67	RES. CHIP 510 5% 20X40
R303	0662057M98	RES. CHIP 10K 5% 20X40
R304	0662057N39	RES. CHIP 470K 5% 20X40
R305	0662057N39	RES. CHIP 470K 5% 20X40
R306	0662057M98	RES. CHIP 10K 5% 20X40

Ref. Des.	Part Number	Description
R307	0662057N23	RES. CHIP 100K 5% 20X40
R308	0662057M01	RES. CHIP 0 5% 20X40
R309	0662057M98	RES. CHIP 10K 5% 20X40
R310	0662057M78	RES. CHIP 1500 5% 20X40
R311	0662057M01	RES. CHIP 0 5% 20X40
R312	0662057N47	RES. CHIP 1.0 MEG 5% 20X40
R313	0662057N47	RES. CHIP 1.0 MEG 5% 20X40
R314	0662057M98	RES. CHIP 10K 5% 20X40
R315	0662057M01	RES. CHIP 0 5% 20X40
R316	0662057M01	RES. CHIP 0 5% 20X40
R319	0662057M01	RES. CHIP 0 5% 20X40
R320	0662057M98	RES. CHIP 10K 5% 20X40
R321	0662057M98	RES. CHIP 10K 5% 20X40
R322	NOTPLACED	64AM DUMMY PART NUMBER
R325	0662057M98	RES. CHIP 10K 5% 20X40
R326	0662057M98	RES. CHIP 10K 5% 20X40
R327	0662057N23	RES. CHIP 100K 5% 20X40
R328	0662057N39	RES. CHIP 470K 5% 20X40
R329	0662057M74	RES. CHIP 1000 5% 20X40
R330	0662057M98	RES. CHIP 10K 5% 20X40
R331	0662057M50	RES. CHIP 100 5% 20X40
R332	NOTPLACED	64AM DUMMY PART NUMBER
R333	0662057M74	RES. CHIP 1000 5% 20X40
R334	0662057M56	RES. CHIP 180 5% 20X40
R335	0662057M98	RES. CHIP 10K 5% 20X40
R380	0662057N47	RES. CHIP 1.0 MEG 5% 20X40
R401	0662057M90	RES. CHIP 4700 5% 20X40
R402	0662057M01	RES. CHIP 0 5% 20X40
R403	0662057M01	RES. CHIP 0 5% 20X40
R404	0662057M01	RES. CHIP 0 5% 20X40
R405	0662057M01	RES. CHIP 0 5% 20X40
R406	0662057M01	RES. CHIP 0 5% 20X40
R407	0662057B47	CHIP RES 0 OHMS +/- .050 OHMS
R413	0662057M01	RES. CHIP 0 5% 20X40
R414	0662057M98	RES. CHIP 10K 5% 20X40

Ref. Des.	Part Number	Description
R415	0662057M01	RES. CHIP 0 5% 20X40
R416	0662057M01	RES. CHIP 0 5% 20X40
R417	0662057M01	RES. CHIP 0 5% 20X40
R418	0662057M01	RES. CHIP 0 5% 20X40
R419	0662057M98	RES. CHIP 10K 5% 20X40
R427	NOTPLACED	64AM DUMMY PART NUMBER
R440	NOTPLACED	64AM DUMMY PART NUMBER
R441	NOTPLACED	64AM DUMMY PART NUMBER
R442	0662057M01	RES. CHIP 0 5% 20X40
R444	NOTPLACED	64AM DUMMY PART NUMBER
R450	0662057N15	RES. CHIP 47K 5% 20X40
R451	0662057M78	RES. CHIP 1500 5% 20X40
R452	0662057M42	RES. CHIP 47 5% 20X40
R453	0662057N11	RES. CHIP 33K 5% 20X40
R454	0662057M64	RES. CHIP 390 5% 20X40
R455	0662057M74	RES. CHIP 1000 5% 20X40
R456	NOTPLACED	64AM DUMMY PART NUMBER
R457	0662057M90	RES. CHIP 4700 5% 20X40
R461	NOTPLACED	64AM DUMMY PART NUMBER
R501	0662057M01	RES. CHIP 0 5% 20X40
R502	0662057M01	RES. CHIP 0 5% 20X40
R503	0662057M01	RES. CHIP 0 5% 20X40
R504	0662057N06	RES. CHIP 20K 5% 20X40
R505	0662057M98	RES. CHIP 10K 5% 20X40
R507	NOTPLACED	64AM DUMMY PART NUMBER
R508	0662057U60	RES CHIP 220 1% 1/16w
R509	0662057V02	RES CHIP 10K 1% 1/16W
R510	0662057M98	RES. CHIP 10K 5% 20X40
R511	NOTPLACED	64AM DUMMY PART NUMBER
R512	0662057V04	RES CHIP 12K 1% 1/16W
R514	0662057N06	RES. CHIP 20K 5% 20X40
R515	0662057M98	RES. CHIP 10K 5% 20X40
R516	0662057M67	RES. CHIP 510 5% 20X40

Ref. Des.	Part Number	Description
R519	0662057M98	RES. CHIP 10K 5% 20X40
R520	0662057U84	RES CHIP 2K 1% 1/16W
R522	0662057N15	RES. CHIP 47K 5% 20X40
R523	0662057N15	RES. CHIP 47K 5% 20X40
R524	0662057N17	RES. CHIP 56K 5% 20X40
R525	0662057M94	RES. CHIP 6800 5% 20X40
R526	0662057V02	RES CHIP 10K 1% 1/16W
R527	0662057M74	RES. CHIP 1000 5% 20X40
R528	0662057M74	RES. CHIP 1000 5% 20X40
R531	0662057M64	RES. CHIP 390 5% 20X40
R533	0662057M82	RES. CHIP 2200 5% 20X40
R536	0662057N23	RES. CHIP 100K 5% 20X40
R537	0662057N10	RES. CHIP 30K 5% 20X40
R538	0662057M01	RES. CHIP 0 5% 20X40
R539	0662057M01	RES. CHIP 0 5% 20X40
R540	0662057M95	RES. CHIP 7500 5% 20X40
R545	0662057M98	RES. CHIP 10K 5% 20X40
R548	0662057N06	RES. CHIP 20K 5% 20X40
R549	0662057M96	RES. CHIP 8200 5% 20X40
R550	0662057V25	RES CHIP 82K 1% 1/16
R551	0662057N06	RES. CHIP 20K 5% 20X40
R553	0662057M96	RES. CHIP 8200 5% 20X40
R554	0662057V25	RES CHIP 82K 1% 1/16
R555	0662057M74	RES. CHIP 1000 5% 20X40
R556	0662057N06	RES. CHIP 20K 5% 20X40
R557	0662057M98	RES. CHIP 10K 5% 20X40
R558	0662057M94	RES. CHIP 6800 5% 20X40
R559	0662057M98	RES. CHIP 10K 5% 20X40
R560	0662057M01	RES. CHIP 0 5% 20X40
R561	0662057M74	RES. CHIP 1000 5% 20X40
R563	0662057M67	RES. CHIP 510 5% 20X40
R564	0662057M98	RES. CHIP 10K 5% 20X40
R565	0662057M82	RES. CHIP 2200 5% 20X40
R566	0662057M95	RES. CHIP 7500 5% 20X40
R567	0662057N15	RES. CHIP 47K 5% 20X40
R568	0662057N15	RES. CHIP 47K 5% 20X40
R569	0662057M90	RES. CHIP 4700 5% 20X40
R572	0662057M50	RES. CHIP 100 5% 20X40
R573	0662057N23	RES. CHIP 100K 5% 20X40

Ref. Des.	Part Number	Description
R574	0662057N23	RES. CHIP 100K 5% 20X40
R575	0662057M98	RES. CHIP 10K 5% 20X40
R576	0662057N23	RES. CHIP 100K 5% 20X40
R577	0662057N15	RES. CHIP 47K 5% 20X40
R578	0662057N15	RES. CHIP 47K 5% 20X40
R581	0662057M01	RES. CHIP 0 5% 20X40
R582	0662057M90	RES. CHIP 4700 5% 20X40
R583	0662057M90	RES. CHIP 4700 5% 20X40
R584	0662057M98	RES. CHIP 10K 5% 20X40
R585	0662057M98	RES. CHIP 10K 5% 20X40
R586	0662057N39	RES. CHIP 470K 5% 20X40
R587	0662057M34	RES. CHIP 22 5% 20X40
R588	0662057M34	RES. CHIP 22 5% 20X40
R589	0662057M98	RES. CHIP 10K 5% 20X40
R590	NOTPLACED	64AM DUMMY PART NUMBER
R591	NOTPLACED	64AM DUMMY PART NUMBER
R592	0662057M50	RES. CHIP 100 5% 20X40
R593	0662057M50	RES. CHIP 100 5% 20X40
R594	0662057M64	RES. CHIP 390 5% 20X40
R595	0662057B47	CHIP RES 0 OHMS +/-0.050 OHMS
R596	NOTPLACED	64AM DUMMY PART NUMBER
R597	0662057M01	RES. CHIP 0 5% 20X40
R598	0662057M60	RES. CHIP 270 5% 20X40
R599	NOTPLACED	64AM DUMMY PART NUMBER
SH101	2685462E01	SHEILD PATRIOT
SH102	2685665E01	SHEILD FLIPPER
U201	5109731C15	IC OP AMP SNGL OPA237 SOT23
U202	5109731C15	IC OP AMP SNGL OPA237 SOT23
U301	5185368C66	IC CUSTOM FLIPPER
U302	5105492X92	IC CMOS BILATERAL SWITCH
U303	5109522E53	IC SNGL BUF NC7S125P5X SC70
U304	5109522E53	IC SNGL BUF NC7S125P5X SC70

Ref. Des.	Part Number	Description
U305	5109522E53	IC SNGL BUF NC7S125P5X SC70
U306	5109522E53	IC SNGL BUF NC7S125P5X SC70
U307	5109522E53	IC SNGL BUF NC7S125P5X SC70
U308	5109817F62	IC SPDT SWITCH/ MULTIPLEXER
U309	5109817F62	IC SPDT SWITCH/ MULTIPLEXER
U310	5187970L15	IC USB TRANS FULL-SPEED
U311	5105492X03	IC SNG HI SPD L-MOS NOT GATE
U312	5185368C12	IC 1.8V SN LOGIC GATE
U314	5109522E53	IC SNGL BUF NC7S125P5X SC70
U401	5185956E51	IC PATRIOT BRAVO 1.0.2
U402	5185956E15	IC FLASH 64MB 1.8V 60NS
U403	5185368C82	IC 1.65 TO 2.2V, 70NS, 8MBIT SRAM
U404	5109522E53	IC SNGL BUF NC7S125P5X SC70
U405	5109522E53	IC SNGL BUF NC7S125P5X SC70
U406	5105492X03	IC SNG HI SPD L-MOS NOT GATE
U407	5105109Z31	IC QUAD 2:1 MUX/DEMUX
U408	5109522E53	IC SNGL BUF NC7S125P5X SC70
U501	5109879E58	IC,COMP,,AUDIO AND POWER MANAGEMENT
U502	5109731C15	IC OP AMP SNGL OPA237 SOT23
U503	5102463J44	AUDIO AMPLIFIER TDA8547TS
U504	5109731C15	IC OP AMP SNGL OPA237 SOT23
U505	5185353D13	IC MINI SO-8 HI PRECISION REG 5V
U507	5109731C15	IC OP AMP SNGL OPA237 SOT23
U508	5113816A73	IC ADJST 1.7% TOL SHUNT REG 20MA
U509	5185353D35	IC DUAL EEPOT 256 TAP

Ref. Des.	Part Number	Description
U510	5105492X92	IC CMOS BILATERAL SWITCH
U511	5185353D56	IC 3.3V LINEAR REGULATOR MC78LC 33N
U512	NOTPLACED	64AM DUMMY PART NUMBER
VR201	4813832C72	TRANS SUP QUAD 12V
VR202	4813830A22	DIODE 9.1V 5% 225MW MMBZ5239B_
VR203	4813832C72	TRANS SUP QUAD 12V
VR204	4813830C26	DIODE 13V 'H3' MMSZ5243BT1
VR205	4805656W08	DIODE ZENER QUAD
VR206	4805656W08	DIODE ZENER QUAD
VR209	4813832C72	TRANS SUP QUAD 12V
VR220	4805656W03	DIODE DUAL 5.6V ZENER
VR221	4805656W03	DIODE DUAL 5.6V ZENER
VR501	4813830A15	DIODE 5.6V 5% 225MW MMBZ5232B_
Y301	4809995L05	XTAL QUARTZ 32.768KHZ CC4V-T1

---

# Glossary

This glossary contains an alphabetical listing of terms and their definitions that are applicable to ASTRO portable and mobile subscriber radio products. All terms do not necessarily apply to all radios, and some terms are merely generic in nature.

Term	Definition
<b>A/D</b>	<i>See analog-to-digital conversion.</i>
<b>Abacus IC</b>	A custom integrated circuit providing a digital receiver intermediate frequency (IF) backend.
<b>ADC</b>	<i>See analog-to-digital converter.</i>
<b>ADDAG</b>	<i>See Analog-to-Digital, Digital-to-Analog and Glue.</i>
<b>ALC</b>	<i>See automatic level control.</i>
<b>analog</b>	Refers to a continuously variable signal or a circuit or device designed to handle such signals. <i>See also digital.</i>
<b>Analog-to-Digital, Digital-to-Analog and Glue</b>	An integrated circuit designed to be an interface between the radio's DSP, which is digital, and the analog transmitter and receiver ICs.
<b>analog-to-digital conversion</b>	Conversion of an instantaneous dc voltage level to a corresponding digital value. <i>See also D/A.</i>
<b>analog-to-digital converter</b>	A device that converts analog signals into digital data. <i>See also DAC.</i>
<b>automatic level control</b>	A circuit in the transmit RF path that controls RF power amplifier output, provides leveling over frequency and voltage, and protects against high VSWR.
<b>band</b>	Frequencies allowed for a specific purpose.
<b>BBP</b>	<i>See baseband interface port.</i>
<b>baseband interface port</b>	Synchronous serial interface to the transceiver board used to transfer transmit and receive audio data.
<b>BGA</b>	<i>See ball grid array.</i>
<b>ball grid array</b>	A type of IC package characterized by solder balls arranged in a grid that are located on the underside of the package.
<b>CODEC</b>	<i>See coder/decoder.</i>

---

---

Term	Definition
<b>codeplug</b>	Firmware that contains the unique personality for a system or device. A codeplug is programmable and allows changes to system and unit parameters. <i>See also firmware.</i>
<b>coder/decoder</b>	A device that encodes or decodes a signal.
<b>CPS</b>	<i>See Customer Programming Software.</i>
<b>Customer Programming Software</b>	Software with a graphical user interface containing the feature set of an ASTRO radio. <i>See also RSS.</i>
<b>D/A</b>	<i>See digital-to-analog conversion.</i>
<b>DAC</b>	<i>See digital-to-analog converter.</i>
<b>Data communication equipment</b>	Definition for device (such as radio) data communications using the RS232 protocol. The correct data communication wiring requires the device's TX pins (output) to connect to the RX pins (input) and the RTS pins (output) to connect to the CTS pins (input). It is incorrect to attach device pins having the same name to to each other.
<b>Data terminal equipment</b>	Data terminal equipment; for example, a computer.
<b>DCE</b>	<i>See Data communication equipment.</i>
<b>default</b>	A pre-defined set of parameters.
<b>digital</b>	Refers to data that is stored or transmitted as a sequence of discrete symbols from a finite set; most commonly this means binary data represented using electronic or electromagnetic signals. <i>See also analog.</i>
<b>digital-to-analog conversion</b>	Conversion of a digital signal to a voltage that is proportional to the input value. <i>See also A/D.</i>
<b>digital-to-analog converter</b>	A device that converts digital data into analog signals. <i>See also ADC.</i>
<b>Digital Private-Line</b>	A type of digital communication that utilizes privacy call, as well as memory channel and busy channel lock-out to enhance communication efficiency.
<b>digital signal processor</b>	A microcontroller specifically designed for performing the mathematics involved in manipulating analog information, such as sound, that has been converted into a digital form. DSP also implies the use of a data compression technique.
<b>digital signal processor code</b>	Object code executed by the Digital Signal Processor in an ASTRO subscriber radio. The DSP is responsible for computation-intensive tasks, such as decoding ASTRO signaling.

Term	Definition
<b>DPL</b>	<i>See Digital Private-Line. See also PL.</i>
<b>DSP</b>	<i>See digital signal processor.</i>
<b>DSP code</b>	<i>See digital signal processor code.</i>
<b>DTE</b>	<i>See Data terminal equipment.</i>
<b>DTMF</b>	<i>See dual tone multi-frequency.</i>
<b>dual tone multi-frequency</b>	The system used by touch-tone telephones. DTMF assigns a specific frequency, or tone, to each key so that it can easily be identified by a microprocessor.
<b>EEPOT</b>	Electrically Programmable Digital Potentiometer.
<b>EEPROM</b>	<i>See Electrically Erasable Programmable Read-Only Memory.</i>
<b>Electrically Erasable Programmable Read-Only Memory</b>	A special type of PROM that can be erased by exposing it to an electrical charge. An EEPROM retains its contents even when the power is turned off.
<b>FCC</b>	Federal Communications Commission.
<b>firmware</b>	Code executed by an embedded processor such as the Host or DSP in a subscriber radio. This type of code is typically resident in non-volatile memory and as such is more difficult to change than code executed from RAM.
<b>FGU</b>	<i>See frequency generation unit.</i>
<b>flash</b>	A non-volatile memory device similar to an EEPROM. Flash memory can be erased and reprogrammed in blocks instead of one byte at a time.
<b>FLASHcode</b>	A 13-digit code which uniquely identifies the System Software Package and Software Revenue Options that are enabled in a particular subscriber radio. FLASHcodes are only applicable for radios which are upgradeable through the FLASHport process.
<b>FLASHport</b>	A Motorola term that describes the ability of a radio to change memory. Every FLASHport radio contains a FLASHport EEPROM memory chip that can be software written and rewritten to, again and again.
<b>FMR</b>	<i>See Florida Manual Revision.</i>
<b>Florida Manual Revision</b>	A document that provides interim updates to a publication until the entire publication can be updated and reissued.
<b>frequency</b>	Number of times a complete electromagnetic-wave cycle occurs in a fixed unit of time (usually one second).

Term	Definition
<b>frequency generation unit</b>	This unit generates ultra-stable, low-phase noise master clock and other derived synchronization clocks that are distributed throughout the communication network.
<b>General-Purpose Input/Output</b>	Pins whose function is programmable.
<b>GPIO</b>	<i>See General-Purpose Input/Output.</i>
<b>host code</b>	Object code executed by the host processor in an ASTRO subscriber radio. The host is responsible for control-oriented tasks such as decoding and responding to user inputs.
<b>IC</b>	<i>See integrated circuit.</i>
<b>IF</b>	Intermediate Frequency.
<b>IMBE</b>	A sub-band, voice-encoding algorithm used in ASTRO digital voice.
<b>inbound signaling word</b>	Data transmitted on the control channel from a subscriber unit to the central control unit.
<b>integrated circuit</b>	An assembly of interconnected components on a small semiconductor chip, usually made of silicon. One chip can contain millions of microscopic components and perform many functions.
<b>ISW</b>	<i>See inbound signaling word.</i>
<b>keep-alive mode</b>	A software-controlled operational mode in which power for the radio remains on after the On/Off/volume control knob is turned off to allow the microcontroller unit to complete its power-down sequence. Then, the radio completely powers off.
<b>key-variable loader</b>	A device used to load encryption keys into a radio.
<b>kHz</b>	<i>See kilohertz.</i>
<b>kilohertz</b>	One thousand cycles per second. Used especially as a radio-frequency unit.
<b>KVL</b>	<i>See key-variable loader.</i>
<b>LCD</b>	<i>See liquid-crystal display.</i>
<b>LED</b>	<i>See light emitting diode.</i>
<b>light emitting diode</b>	An electronic device that lights up when electricity is passed through it.
<b>liquid-crystal display</b>	An LCD uses two sheets of polarizing material with a liquid-crystal solution between them. An electric current passed through the liquid causes the crystals to align so that light cannot pass through them.
<b>LO</b>	Local oscillator.



Term	Definition
<b>low-speed handshake</b>	150-baud digital data sent to the radio during trunked operation while receiving audio.
<b>LSH</b>	<i>See low-speed handshake.</i>
<b>Master In Slave Out</b>	SPI data line from a peripheral to the MCU.
<b>Master Out Slave In</b>	SPI data line from the MCU to a peripheral.
<b>MCU</b>	<i>See microcontroller unit.</i>
<b>MDC</b>	Motorola Digital Communications.
<b>MDI</b>	MCU/DSP Interface internal to the Patriot IC.
<b>MHz</b>	<i>See Megahertz.</i>
<b>Megahertz</b>	One million cycles per second. Used especially as a radio-frequency unit.
<b>microcontroller unit</b>	Also written as $\mu\text{C}$ . A microprocessor that contains RAM and ROM components, as well as communications and programming components and peripherals.
<b>MISO</b>	<i>See Master In Slave Out.</i>
<b>MOSI</b>	<i>See Master Out Slave In.</i>
<b>multiplexer</b>	An electronic device that combines several signals for transmission on some shared medium (e.g., a telephone wire).
<b>MUX</b>	<i>See multiplexer.</i>
<b>NiCd</b>	Nickel-cadmium.
<b>NiMH</b>	Nickel-metal-hydride.
<b>OMPAC</b>	<i>See over-molded pad-array carrier.</i>
<b>open architecture</b>	A controller configuration that utilizes a microprocessor with extended ROM, RAM, and EEPROM.
<b>oscillator</b>	An electronic device that produces alternating electric current and commonly employs tuned circuits and amplifying components.
<b>OSW</b>	<i>See outbound signaling word.</i>
<b>OTAR</b>	<i>See over-the-air rekeying.</i>
<b>outbound signaling word</b>	Data transmitted on the control channel from the central controller to the subscriber unit.
<b>over-molded pad-array carrier</b>	A Motorola custom IC package, distinguished by the presence of solder balls on the bottom pads.

Term	Definition
<b>over-the-air rekeying</b>	Allows the dispatcher to remotely reprogram the encryption keys in the radio.
<b>PA</b>	Power amplifier.
<b>paging</b>	One-way communication that alerts the receiver to retrieve a message.
<b>Patriot IC</b>	A dual-core processor that contains an MCU and a DSP in one IC package.
<b>PC Board</b>	Printed Circuit Board. Also referred to as a PCB.
<b>phase-locked loop</b>	A circuit in which an oscillator is kept in phase with a reference, usually after passing through a frequency divider.
<b>PL</b>	<i>See private-line tone squelch.</i>
<b>PLL</b>	<i>See phase-locked loop.</i>
<b>private-line tone squelch</b>	A continuous sub-audible tone that is transmitted along with the carrier. <i>See also DPL.</i>
<b>Programmable Read-Only Memory</b>	A memory chip on which data can be written only once. Once data has been written onto a PROM, it remains there forever.
<b>PROM</b>	<i>See Programmable Read-Only Memory.</i>
<b>PTT</b>	<i>See Push-to-Talk.</i>
<b>Push-to-Talk</b>	The switch or button usually located on the left side of the radio which, when pressed, causes the radio to transmit. When the PTT is released, the unit returns to receive operation.
<b>radio frequency</b>	The portion of the electromagnetic spectrum between audio sound and infrared light (approximately 10 kHz to 10 GHz).
<b>radio frequency power amplifier</b>	Amplifier having one or more active devices to amplify radio signals.
<b>Radio Interface Box</b>	A service aid used to enable communications between a radio and the programming software.
<b>Radio Service Software</b>	DOS-based software containing the feature set of an ASTRO radio. <i>See also CPS.</i>
<b>RAM</b>	<i>See random access memory.</i>
<b>random access memory</b>	A type of computer memory that can be accessed randomly; that is, any byte of memory can be accessed without touching the preceding bytes.
<b>read-only memory</b>	A type of computer memory on which data has been prerecorded. Once data has been written onto a ROM chip, it cannot be removed and can only be read.

Term	Definition
<b>real-time clock</b>	A module that keeps track of elapsed time even when a computer is turned off.
<b>receiver</b>	Electronic device that amplifies RF signals. A receiver separates the audio signal from the RF carrier, amplifies it, and converts it back to the original sound waves.
<b>registers</b>	Short-term data-storage circuits within the microcontroller unit or programmable logic IC.
<b>repeater</b>	Remote transmit/receive facility that re-transmits received signals in order to improve communications range and coverage (conventional operation).
<b>repeater/talkaround</b>	A conventional radio feature that permits communication through a receive/transmit facility, which re-transmits received signals in order to improve communication range and coverage.
<b>RESET</b>	Reset line: an input to the microcontroller that restarts execution.
<b>RF</b>	<i>See radio frequency.</i>
<b>RF PA</b>	<i>See radio frequency power amplifier.</i>
<b>RIB</b>	<i>See Radio Interface Box.</i>
<b>ROM</b>	<i>See read-only memory.</i>
<b>RPCIC</b>	Regulator/power control IC.
<b>RSS</b>	<i>See Radio Service Software.</i>
<b>RTC</b>	<i>See real-time clock.</i>
<b>RX</b>	Receive.
<b>RX DATA</b>	Recovered digital data line.
<b>SAP</b>	<i>See Serial Audio CODEC Port.</i>
<b>SCI IN</b>	<i>See Serial Communication Interface Input Line.</i>
<b>Serial Audio CODEC Port</b>	SSI to and from the GCAP II IC CODEC used to transfer transmit and receive audio data.
<b>Serial Communication Interface Input Line</b>	A full-duplex (receiver/transmitter) asynchronous serial interface.
<b>Serial Input/Output IC</b>	An integrated circuit that provides SB9600 serial and power-control functions.
<b>Serial Peripheral Interface</b>	How the microcontroller communicates to modules and ICs through the CLOCK and DATA lines.

Term	Definition
<b>signal</b>	An electrically transmitted electromagnetic wave.
<b>Signal Qualifier mode</b>	An operating mode in which the radio is muted, but still continues to analyze receive data to determine RX signal type.
<b>SIO IC</b>	<i>See Serial Input/Output IC.</i>
<b>Smart Radio Interface Box</b>	A service aid containing microcontroller buffered RAM that enhances the speed and capability of programming a radio with programming software.
<b>softpot</b>	<i>See software potentiometer.</i>
<b>software</b>	Computer programs, procedures, rules, documentation, and data pertaining to the operation of a system.
<b>software potentiometer</b>	A computer-adjustable electronic attenuator.
<b>spectrum</b>	Frequency range within which radiation has specific characteristics.
<b>SPI</b>	<i>See Serial Peripheral Interface.</i>
<b>squelch</b>	Muting of audio circuits when received signal levels fall below a pre-determined value. With carrier squelch, all channel activity that exceeds the radio's preset squelch level can be heard.
<b>SRAM</b>	<i>See static RAM.</i>
<b>SRIB</b>	<i>See Smart Radio Interface Box.</i>
<b>SSI</b>	<i>See Synchronous Serial Interface.</i>
<b>Standby mode</b>	An operating mode in which the radio is muted but still continues to monitor data.
<b>static RAM</b>	A type of memory used for volatile, program/data memory that does not need to be refreshed.
<b>Synchronous Serial Interface</b>	DSP interface to peripherals that consists of a clock signal line, a frame synchronization signal line, and a data line.
<b>system central controllers</b>	Main control unit of the trunked dispatch system; handles ISW and OSW messages to and from subscriber units ( <i>See ISW and OSW</i> ).
<b>system select</b>	The act of selecting the desired operating system with the system-select switch (also, the name given to this switch).
<b>talkaround</b>	A conventional radio feature that lets you bypass the repeater and connect directly to another radio. The transmit and receive frequencies are the same.
<b>thin small-outline package</b>	A type of dynamic random-access memory (DRAM) package that is commonly used in memory applications.

Term	Definition
<b>time-out timer</b>	A timer that limits the length of a transmission.
<b>TOT</b>	<i>See time-out timer.</i>
<b>transceiver</b>	Transmitter-receiver. A device that both transmits and receives analog or digital signals. Also abbreviated as XCVR.
<b>transmitter</b>	Electronic equipment that generates and amplifies an RF carrier signal, modulates the signal, and then radiates it into space.
<b>TSOP</b>	<i>See thin small-outline package.</i>
<b>TX</b>	Transmit.
<b>UART</b>	<i>See also Universal Asynchronous Receiver Transmitter.</i>
<b>UHF</b>	Ultra-High Frequency.
<b>Universal Asynchronous Receiver Transmitter</b>	A microchip with programming that controls a computer's interface to its attached serial devices.
<b>Universal Serial Bus</b>	An external bus standard that supports data transfer rates of 12 Mbps.
<b>USB</b>	<i>See Universal Serial Bus.</i>
<b>VCO</b>	<i>See voltage-controlled oscillator.</i>
<b>vector sum excited linear predictive coding</b>	A voice-encoding technique used in ASTRO digital voice.
<b>VHF</b>	Very-High Frequency.
<b>VIP</b>	Vehicle Interface Port.
<b>VOCON</b>	<i>See vocoder/controller.</i>
<b>vocoder</b>	An electronic device for synthesizing speech by implementing a compression algorithm particular to voice. <i>See also voice encoder.</i>
<b>vocoder/controller</b>	A PC board that contains an ASTRO radio's microcontroller, DSP, memory, audio and power functions, and interface support circuitry.
<b>voice encoder</b>	The DSP-based system for digitally processing analog signals, and includes the capabilities of performing voice compression algorithms or voice encoding. <i>See also vocoder.</i>
<b>voltage-controlled oscillator</b>	An oscillator in which the frequency of oscillation can be varied by changing a control voltage.
<b>VSELP</b>	<i>See vector sum excited linear predictive coding.</i>

## Notes

# Index

## Numerics

13 MHz reference generation, flipper IC 3-27  
 32 kHz oscillator, flipper IC 3-26  
 5-volt regulator U505, VOCON 3-23

## A

Abacus III IC U500 3-7  
 algorithms, encryption module 3-34  
 amplifier  
   audio power U503 3-24  
   audio pre-amplifier U502 3-24  
   driver U102 3-9  
   power transistor 3-10  
   summing U106 3-11  
 antenna port J2 3-5  
 antenna switch, transmitter 3-10  
 audio  
   circuitry, GCAP II IC U501 3-23  
   components, VOCON board 3-22  
   power amplifier U503 3-24  
   pre-amplifier U502 3-24  
 audio path  
   receive 3-33  
   transmit 3-32  
 automatic level control (ALC), PCIC 3-12

## B

baseband interface port (BBP) 3-19  
 battery  
   connector J3 3-3  
   types and capacities 2-1  
 block diagram  
   Abacus III IC U500 3-7  
   overall 3-2  
   power distribution  
     700-800 MHz 2-2  
     UHF 2-2  
     VHF 2-2  
   receiver 3-5  
   transceiver 3-2, 3-3  
 board overlays  
   transceiver (RF) board  
     700-800 MHz 8-10  
     UHF 8-55  
     VHF 8-41  
   transceiver list 8-1  
 VOCON board  
   NTN9564B 8-103  
   NTN9564C 8-117  
   VOCON list 8-1  
 boot data path control, flipper IC 3-25

## C

caution symbol meaning 1-2

charts, troubleshooting  
   button test 5-16  
   channel/zone select error 5-15  
   DC supply failure 5-5  
   display failure  
     800 MHz 5-11  
     VHF 5-8  
   keyload failure 5-34  
   list 5-1  
   main 5-2  
   power-up failure 5-3  
   secure hardware failure 5-35  
   top/side button test 5-17  
   VCO Tx/Rx unlock 5-18  
   VOCON  
     Rx audio 5-21  
     Rx RF 5-23  
     Tx audio 5-19  
     Tx RF (UHF R1/700-800 MHz) 5-31  
     Tx RF (VHF) 5-28  
     volume set error 5-14  
 CMOS support, flipper IC 3-26  
 components  
   block diagram 3-2  
   controller (VOCON) 3-17  
   encryption module 3-34  
   keypad module 3-30  
   universal flex assembly 3-30  
 connector  
   display module P301 3-17  
   encryption J701 3-17  
   keypad module P107 3-17  
   RF interface P201 3-17  
   universal J101 3-17  
 controller components, VOCON board 3-17  
 controls and control top flex, VOCON board 3-30

## D

D/A outputs, PCIC 3-13  
 danger symbol meaning 1-2  
 detailed theory  
   transceiver (RF) board 3-2  
   VOCON board 3-16  
 digital signal processor (DSP)  
   baseband interface port (BBP) 3-19  
   detailed theory 3-19  
   serial audio CODEC port (SAP) 3-20  
   timer module 3-19  
   universal serial bus (USB) 3-20  
 directional coupler U101, transmitter 3-10  
 display module  
   connector P301 3-17  
   VOCON board 3-29  
 driver amplifier U102 3-9

## E

EEPOT potentiometer U509 3-24  
 encryption  
   connector J701 3-17  
   module 3-34  
   module algorithms 3-34

errors, power-up self-check 4-5  
ESD protection circuitry, VOCON board 3-27  
external interface module (EIM) 3-18

## F

Flash memory IC U402 3-21  
flipper IC U301  
    13 MHz reference generation 3-27  
    32 kHz oscillator 3-26  
    boot data path control 3-25  
    CMOS support 3-26  
    detailed theory 3-25  
    logic level translation 3-25  
    one-wire support 3-26  
    side interface connector 3-25  
    SSI clock and frame sync generator 3-27  
    USB transceiver 3-25  
    watchdog timer 3-26  
FracN IC U202 3-14  
frequency generator unit (FGU)  
    FracN IC U202 3-14  
    loop filter 3-15  
    reference oscillator Y200 3-14  
    VCO buffer IC (VCOBIC) U200 3-15

## G

GCAP II IC U501  
    audio circuitry 3-23  
    detailed theory 3-22  
    MCU interface 3-23  
    power routing 2-3  
    voltage regulation 3-22  
global control audio and power II IC 501  
    See *GCAP II IC U501*  
glossary Glossary-1

## H

handling precautions, troubleshooting 4-1  
harmonic filter, transmitter 3-11

## I

IC  
    Abacus III U500 3-7  
    directional coupler U101 3-10  
    driver amplifier U102 3-9  
    Flash memory U402 3-21  
    flipper U301 3-25  
    FracN U202 3-14  
    GCAP II U501 3-22  
    Patriot U401 3-18  
    power-control (PCIC) U104 3-11  
    static RAM (SRAM) U403 3-20  
    summing amplifier U106 3-11  
IF filter, receiver front end 3-6  
interconnections  
    transceiver 3-3  
    VOCON board 3-16  
interface support components, VOCON board 3-24

## K

keep-alive mode 2-2  
key variable loader (KVL) 3-34  
keypad module  
    connector P107 3-17  
    description 3-30  
    VOCON board 3-30  
KVL (key variable loader) 3-34

## L

LNA, receiver front end 3-6  
logic level translation, flipper IC 3-25  
loop filter, FGU 3-15

## M

manual  
    notations 1-2  
MCU interface, GCAP II IC U501 3-23  
memory components, VOCON board 3-17  
microcontroller unit (MCU)  
    description 3-18  
    external interface module (EIM) 3-18  
    multiple queue serial peripheral interface (MQSPI) 3-19  
    one-way interface 3-19  
    universal asynchronous receiver/transmitter (UART) 3-19  
mixer, receiver front end 3-6  
mode, keep-alive 2-2  
model chart  
    UHF  
        non-ruggedized 3-xxii  
        ruggedized 3-xxiii  
module  
    encryption 3-34  
    keypad 3-30  
multiple queue serial peripheral interface (MQSPI) 3-19

## N

notations in manual 1-2

## O

one-way interface 3-19  
one-wire support, flipper IC 3-26  
option selects, universal connector 3-29  
oscillator  
    32 kHz 3-26  
    reference Y200, FGU 3-14  
    sampling clock 3-8  
    second local 3-8  
    voltage-controlled (VCO) 3-8  
overview  
    keypad module 3-30  
    universal flex assembly 3-30  
    VOCON board 3-16



**P**

## parts list

- transceiver (RF) board
  - 700-800 MHz 8-12, 8-26
  - UHF 8-57, 8-73
  - VHF 8-43

## VOCON board

- NNTN4563A/B 8-133
- NNTN4717D 8-162
- NNTN4819A 8-148
- NTN9564B 8-105
- NTN9564C 8-119

## Patriot IC U401

- description 3-18
- digital signal processor (DSP) 3-19
- microcontroller unit (MCU) 3-18

## PCIC (power-control IC) U104

- automatic level control (ALC) 3-12
- D/A outputs 3-13
- detailed theory 3-11
- purpose 3-8
- temperature cut back 3-13
- voltage multiplier 3-12
- voltage regulator 3-12

## power

- amplifier transistor 3-10
- components, VOCON board 3-22
- conditioning components, transceiver 3-5

power control IC U104 *See PCIC (power control IC) U104*

## power distribution

- block diagram
  - 700-800 MHz 2-2
  - UHF 2-2
  - VHF 2-2

## keep-alive mode 2-2

## radio 2-1

## transceiver board 2-3

## transmitter 3-9

## VOCON board 2-3

## power-up self-check

- diagnostics and repair 4-6
- errors 4-5

## power-up/power-down sequence 3-33

## preselector filters, receiver front end 3-6

**R**

## radio

- keep-alive mode 2-2
- power distribution 2-1
- power-up/power-down sequence 3-33

## receive audio path, VOCON board 3-33

## receiver

## back end

- Abacus III IC U500 3-7
- detailed theory 3-7
- sampling clock oscillator 3-8
- second LO 3-8

## block diagram 3-5

## front end

- detailed theory 3-6
- IF filter 3-6

## low-noise amplifier (LNA) 3-6

## mixer 3-6

## preselector filters 3-6

## reference oscillator Y200, FGU 3-14

## RF

- detectors, transmitter 3-11
- interface connector P201 3-17

**S**

## sampling clock oscillator 3-8

## schematics

## transceiver (RF) board 8-3

## transceiver board list 8-1

## VOCON board 8-96

## VOCON board list 8-1

## second LO (local oscillator) 3-8

## serial audio CODEC port (SAP) 3-20

## serial EEPROM 3-5

## service tools, recommended 4-2

## side interface connector, flipper IC 3-25

## signal tracing, troubleshooting 4-3

## SSI clock and frame sync generator, flipper IC 3-27

## standard supply voltages 4-4

## static RAM (SRAM) IC U403 3-20

## summing amplifier U106, transmitter 3-11

## symbols

## caution 1-2

## danger 1-2

## warning 1-2

## system clocks

## troubleshooting 4-4

## VOCON board 3-31

**T**

## temperature cut back, PCIC 3-13

## terms and definitions Glossary-1

## timer module, DSP 3-19

## tools, recommended service 4-2

## transceiver

## antenna port J2 3-5

## battery connector J3 3-3

## block diagram 3-2, 3-3

## board overlays

## 700-800 MHz 8-10

## UHF 8-55

## VHF 8-41

## detailed theory 3-2

## interconnections 3-3

## parts list

## 700-800 MHz 8-12, 8-26

## UHF 8-57, 8-73

## VHF 8-43

## power conditioning 3-5

## power distribution diagram 2-3

## schematics 8-3

## serial EEPROM 3-5

## VOCON connector P1 3-3

## voltage regulators 2-3

## transmit audio path, VOCON board 3-32

## transmitter

## antenna switch 3-10

- directional coupler U101 3-10
- driver amplifier U102 3-9
- harmonic filter 3-11
- introduction 3-8
- PCIC (power-control IC) U104 3-11
- power amplifier transistor 3-10
- power distribution 3-9
- power-control IC (PCIC) 3-8
- RF detectors 3-11
- summing amplifier U106 3-11
- troubleshooting
  - button test 5-16
  - channel/zone select error 5-15
  - charts listing 5-1
  - DC supply failure 5-5
  - display failure
    - 800 MHz 5-11
    - VHF 5-8
  - handling precautions 4-1
  - keyload failure 5-34
  - main chart 5-2
  - power-up failure 5-3
  - power-up self-check
    - diagnostics and repair 4-6
    - errors 4-5
  - secure hardware failure 5-35
  - service tools 4-2
  - signal tracing 4-3
  - standard supply voltages 4-4
  - system clocks 4-4
  - top/side button test 5-17
  - VCO Tx/Rx unlock 5-18
  - VOCON
    - Rx audio 5-21
    - Rx RF 5-23
    - Tx audio 5-19
    - Tx RF (UHF R1/700-800 MHz) 5-31
    - Tx RF (VHF) 5-28
  - voltage measurement 4-3
  - volume set error 5-14
- troubleshooting waveforms
  - 13 MHz clock 6-2
  - 16.8 MHz buffer input and output 6-3
  - 32.768 kHz clock outputs 6-4
  - list 6-1
  - receive baseband interface port (BBP) 6-7
  - RX serial audio port (SAP) 6-6
  - SPI B data 6-5
  - transmit baseband interface port (BBP) 6-8

## U

- UHF
  - model chart
    - non-ruggedized 3-xxii
    - ruggedized 3-xxiii
- UHF R2 2-3
- UHF Range 2 3-xxii, 3-xxiii, 3-xxviii
- UHF Range 2 Model Chart 3-xxii, 3-xxiii
- universal asynchronous receiver/transmitter (UART) 3-19
- universal connector
  - interface circuitry, VOCON board 3-28
  - J101 3-17

- location 3-28
- option selects 3-29
- universal flex assembly 3-30
- universal serial bus (USB) 3-20
- USB transceiver, flipper IC 3-25

## V

- VCO (voltage-controlled oscillator) 3-8
- VCO buffer IC (VCOBIC) U200, FGU 3-15
- VOCON board
  - 5-volt regulator U505 3-23
  - audio
    - components 3-22
    - power amplifier U503 3-24
    - pre-amplifier U502 3-24
  - board overlays
    - NTN9564B 8-103
    - NTN9564C 8-117
  - connector J101 pin-outs 3-28
  - controller components 3-17
  - controls and control top flex 3-30
  - display
    - module 3-29
    - module connector P301 3-17
  - EEPOT potentiometer U509 3-24
  - encryption connector J701 3-17
  - ESD protection circuitry 3-27
  - Flash memory IC U402 3-21
  - flipper IC U301 3-25
  - GCAP II IC U501 3-22
  - interconnections 3-16
  - interface support components 3-24
  - keypad
    - module 3-30
    - module connector P107 3-17
  - memory components 3-17
  - overview 3-16
  - parts list
    - NNTN4563A/B 8-133
    - NNTN4717D 8-162
    - NNTN4819A 8-148
    - NTN9564B 8-105
    - NTN9564C 8-119
  - Patriot IC U401 3-18
  - power components 3-22
  - power distribution 2-3
  - receive audio path 3-33
  - RF interface connector P201 3-17
  - schematics 8-96
  - static RAM (SRAM) IC U403 3-20
  - system clocks 3-31
  - transmit audio path 3-32
  - universal connector interface circuitry 3-28
  - universal connector J101 3-17
- VOCON connector P1 3-3
- voltage
  - measurement, troubleshooting 4-3
  - multiplier, PCIC 3-12
  - regulation, GCAP II IC U501 3-22
  - regulator, PCIC 3-12
  - regulators, transceiver 2-3
  - voltage-controlled oscillator (VCO) 3-8
  - voltages, standard supply 4-4

---

**W**

- warning symbol meaning 1-2
- watchdog timer, flipper IC 3-26
- waveforms, troubleshooting
  - 13 MHz clock 6-2
  - 16.8 MHz buffer input and output 6-3
  - 32.768 kHz clock outputs 6-4
  - list 6-1
  - receive baseband interface port (BBP) 6-7
  - RX serial audio port (SAP) 6-6
  - SPI B data 6-5
  - transmit baseband interface port (BBP) 6-8







Motorola, Inc.  
8000 West Sunrise Boulevard  
Ft. Lauderdale, FL 33322

MOTOROLA, the Stylized M Logo, ASTRO, FLASHport, and CommPort  
are registered in the U.S. Patent and Trademark Office. All other product  
or service names are the property of their respective owners.

© Motorola, Inc. 2004  
All rights reserved. Printed in U.S.A.



**6881094C31-D**